

UNIVERSITY OF VIRGINIA

# PAVILION V

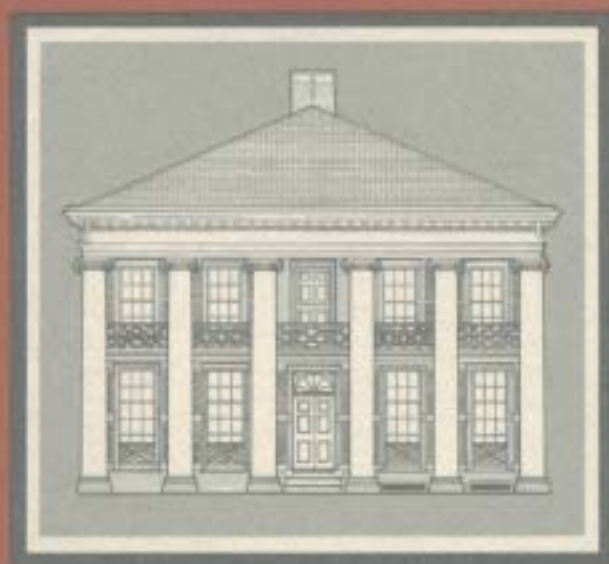

HISTORIC STRUCTURE REPORT

**PAVILION V**  
UNIVERSITY OF VIRGINIA



PAVILION V  
UNIVERSITY OF VIRGINIA

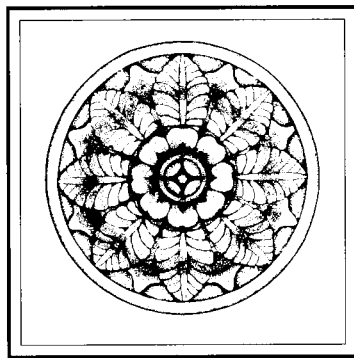

HISTORIC STRUCTURE REPORT

MESICK · COHEN · WAITE  
ARCHITECTS  
1994

© Copyright 1994  
Mesick · Cohen · Waite Architects  
and  
The University of Virginia

*We would like to thank the following groups and individuals  
for their assistance in the preparation of this report.*

The Rector and Visitors of the University of Virginia

The Jeffersonian Restoration Advisory Board

Edward E. Elson, Chairman  
Adele Chatfield-Taylor, Vice Chairman  
Mrs. George M. Cochran, Vice Chairman  
Bahman Batmanghelidj  
Charles L. Brown  
John T. Casteen, III  
Lydia de Polo  
Mario di Valmarana  
Charles H. P. Duell  
Kirkman Finlay, Jr.  
James Marston Fitch  
Mrs. James Stewart Hooker  
James Murray Howard  
Philip Johnson  
Daniel P. Jordan  
Peter O. Lawson-Johnston  
Frederick D. Nichols  
William G. Pannill  
Marion B. Peavey  
Harry W. Porter, Jr.  
Jaquelin T. Robertson  
Mrs. Virginius R. Shackelford, Jr.  
Bayard Sharp  
Mrs. Terence Y. Sieg  
Carl W. Smith  
Robert D. Sweeney  
Mrs. James L. Wiley

The Thomas Jefferson Memorial Foundation (Monticello)

The University of Virginia Department of  
Facilities Management

The University of Virginia School of Architecture

For their individual assistance, we also thank William D. Middleton,  
Ashley Robbins, Nancy Clapp, David Duncan, Bridget Maley, Tina Papamichael,  
Lawton Thies, Nat Tuck, and the residents of the Academical Village.

This project was funded by contributions to  
the Jeffersonian Restoration Advisory Board.

*Prepared for*  
UNIVERSITY OF VIRGINIA

Mesick • Cohen • Waite Architects  
388 Broadway  
Albany, New York 12207

*Partner-in-Charge*  
John G. Waite

*Project Manager*  
Clay S. Palazzo

*Architectural Staff*  
Douglas G. Bucher  
Alan Cerny  
Chelle Jenkins  
Stephen F. Reilly

*Architectural Historian*  
Diana S. Waite

*Cover Design*  
Karelis & Timm Graphic Design

*Publication Consultant*  
Mount Ida Press

# CONTENTS

FOREWORD 9

INTRODUCTION 11

SUMMARY 15

THE JEFFERSONIAN PRECINCT 17

HISTORY 19

ARCHITECTURAL DESCRIPTION 55

PROBLEMS OF REPAIR 149

RECOMMENDATIONS 179





# FOREWORD

This fourth volume in our series of historic structure reports continues a tradition of investigative studies begun in the mid 1980s. The ultimate value of this work is accumulation of documentary evidence that describes each building from its beginnings to the present, just prior to new work. The documentation serves as a background against which well-informed decisions about changes can be made.

The Jeffersonian Restoration Advisory Board has always endorsed the idea that the Academical Village should be used as a laboratory for students of preservation. Beginning in 1990 students working in my office as architectural apprentices or as summer post-graduation interns began measuring and drawing selected pavilions. Their work has been included in the reports for Pavilions II and V. We are especially pleased that they have the opportunity to contribute their talents to the documentation process. Similarly, since 1989, twelve students have served as restoration interns, working in the field alongside skilled craftspersons to develop a deeper understanding of conservation and restoration skills. By such means the intellect and manual craft skills are harmoniously combined.

For work at Pavilion V, the student participants have been Ashley Robbins, Nancy Clapp, David Duncan, Bridget Maley, Tina Papamachael, Lawton Thies, and Nat Tuck. We thank each of them for their outstanding contributions.

JAMES MURRAY HOWARD, AIA  
Curator and Architect for the Academical Village



*Photogravure of the Jeffersonian Precinct, 1903*

# INTRODUCTION

This is the fourth in a series of historic structure reports to be prepared for the buildings of Thomas Jefferson's Academical Village at the University of Virginia. The first report, dealing with Pavilion I, was completed in 1988. It has been followed by other reports on Pavilion VI (1991) and Pavilion II (1992). This report on Pavilion V was begun in 1992 and completed in 1994.

This report, like the three previous studies, strongly advocates the adoption of a sound curatorial approach to the maintenance, renewal, and restoration of the Jefferson buildings at the university. Just as an art conservator would not intervene in the life of an artistic artifact before obtaining a thorough knowledge of its history, composition, and significance, so those engaged in the preservation of buildings and landscapes should proceed only from a basis of knowledge. Far too often in the past, the cultural integrity of buildings and their settings have been compromised by approaches to restoration that have been grounded in personal whim, willful romanticism, and expedient notions of repair and renewal.

Pavilion V, although fundamentally similar to the other pavilions, is different in that it is basically two buildings; the original pavilion received a substantial addition in the early 1850s which was almost as large as the original structure. At that time the two buildings were interconnected by a link or hyphen; yet, for many years the rear addition has served as a separate dwelling. The juxtaposition of the two buildings created an opportunity for placing service functions, such as the kitchen and bathrooms, in the rear addition, thereby allowing the complete preservation of the original Jefferson pavilion.

Another important difference is that Pavilion V retains its original ridge-and-furrow roofing system in the attic. This roof, which is unique to Thomas Jefferson, survives almost completely intact because in the late 1830s, an entirely new slate roof, including framing, was installed, resulting in the original roof becoming, in effect, the floor of the attic. As a result, the rooflets of Pavilion V are now the best

# PAVILION V

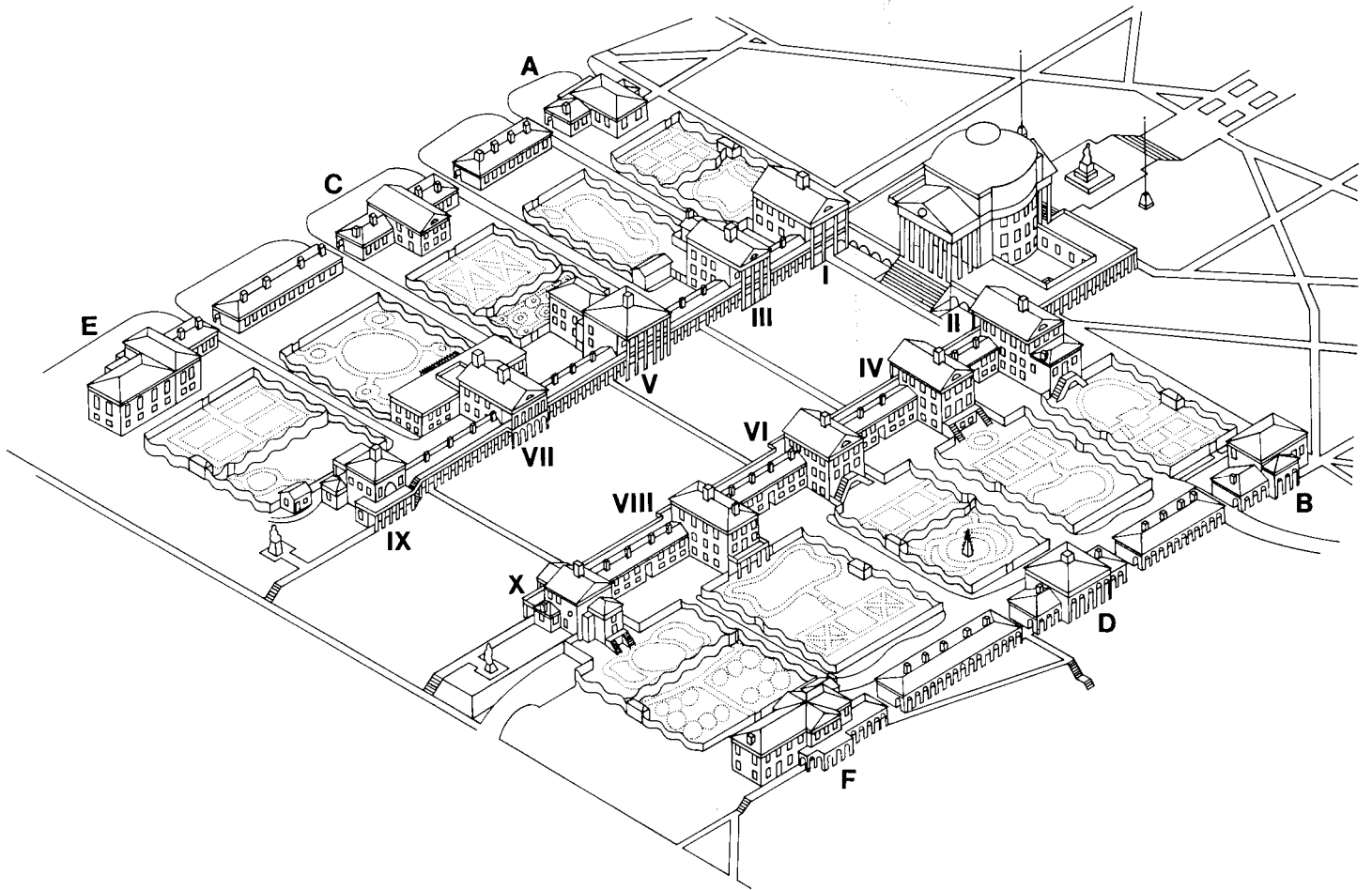

*The Jeffersonian Precinct*

## INTRODUCTION

preserved of any of Jefferson's ridge-and-furrow roofs to have survived, and therefore they are of great significance.

The preparation of a historic structure report is the first step in developing a disciplined approach to the care of a historic building. Over the past year and a half, a team of architects, architectural historians, and building conservators has carried out the surveying and recording of the building. There has been a review of archival information regarding Pavilion V and a thorough examination of its building fabric. All elements of the building have been examined to determine date of origin, existing condition, and scope of needed repair. A permanent graphic and written record of these findings has been prepared. Assembling the minutiae of the building's history and current conditions creates a benchmark that will not only provide a guide for immediate work but will furnish future generations with a clear picture of what was found in our time.

Gleaning from Thomas Jefferson's papers, the university's archives, and other written accounts and graphic materials, it has been possible to assemble a history of the building's design, construction, subsequent alterations, and use. Careful measurement of all exterior and interior features has made possible the preparation of a set of architectural drawings which illustrate the present configuration, as well as the evidence of historical conditions of Pavilion V. Plans, sections and elevations of existing conditions were prepared by Ashley Robbins of the University of Virginia. Details and historical condition drawings were prepared by Alan Cerny and Chelle Jenkins of Mesick·Cohen·Waite Architects.

Along with the reports for Pavilions I, II and VI, the study is part of the ongoing program to prepare historic structure reports on all of the buildings of the Academical Village. This program will establish a framework of knowledge that can lead to a consensus for dealing with the preservation of these important cultural resources.

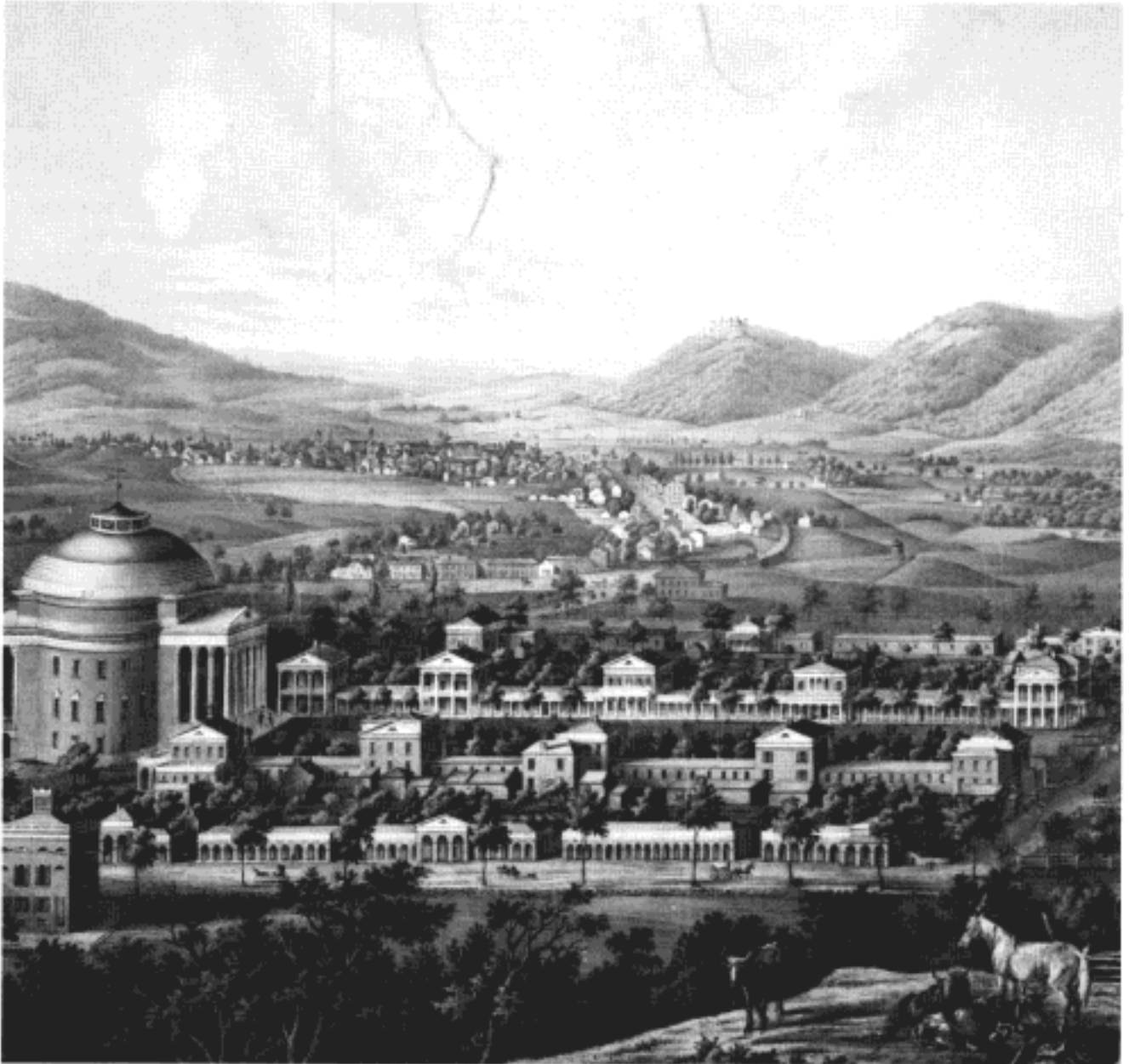

*Detail of the University of Virginia, Charlottesville, and Monticello, from Lewis Mountain,  
printed by F. Sachse and Co. and published by C. Bohn, 1856*

## PAVILION V

# SUMMARY

The construction of Pavilions III and V was authorized by the Board of Visitors of Central College, the predecessor of the University of Virginia, in 1817. However, work on Pavilion V was not started until the middle of 1819. It was completed in 1823.

The contract for the brickwork and carpentry of Pavilion V was awarded to John Perry and James Dinsmore, two workmen who were well known to Thomas Jefferson. Perry had previously worked at both Monticello and Poplar Forest, as well as Pavilions III and VII at the university. Dinsmore was one of Jefferson's most trusted and talented workmen; he had lived at Monticello for more than a dozen years before Pavilion V was begun. In addition to Dinsmore and Perry, a number of other builders familiar to Jefferson worked on Pavilion V. Stonework, including the carving of the six Ionic portico column bases, was carved by John Gorman who had worked at Poplar Forest. Other masons on the job were Samuel Campbell, William B. Phillips and Hugh Chisholm. Some of the plastering was also done by Chisholm. The Ionic column capitals were carved in Carrara, Italy.

Most of the plastering was contracted to Joseph Antrim, who had done similar work on the other pavilions and at Poplar Forest. Lead and composition ornaments were provided by William Coffee of New York City, who had supplied ornaments for Monticello, Poplar Forest, and other pavilions at the university.

Pavilion V was occupied by George Long, professor of ancient languages beginning in 1825. He was succeeded in 1828 by Robert M. Patterson, professor of natural philosophy, who had a small addition built in the rear in 1829 for use as an office. The extent of construction for this office is unknown; no physical evidence pertaining to the structure has been uncovered.

A major change occurred in 1837, when the original ridge-and-furrow roof was replaced by a new roof of slate. At that time the entire roof was reconfigured, new framing was installed for a hipped roof, and the original roof became, in effect, the attic floor.



## PAVILION V

By 1852, the present rear addition and a narrow, two-story connecting link between the addition and the original pavilion had been constructed for Glessner Harrison, professor of ancient languages and occupant of Pavilion V. In 1903, the pavilion was informally converted into two residences occupied by Professor Smith, professor of natural sciences, and Professor Kent, his son-in-law, who was professor of English. Professor Smith resided in Pavilion V for seventy years. After his death in 1928, the Board of Visitors agreed to formally divide the pavilion into two separate residences, each of which was to be occupied by a professor.

The current renovation provides an unusual opportunity to return the building to a single residence, the form it had until 1903. By doing this, the addition can accommodate new bathroom and kitchen facilities, ensuring that the historic form of Jefferson's original pavilion is maintained.

A unique feature of Pavilion V is the original ridge-and-furrow roof that survives, nearly intact, in the attic. The best preserved of any of Jefferson's roofs of this type, this structure is of major importance.

## PAVILION V

# THE JEFFERSONIAN PRECINCT

Originally called the Academical Village, the present Jeffersonian Precinct of the University of Virginia occupies a twenty-eight-acre site in the rolling hills just east of the Shenandoah Valley. The original U-shaped complex of buildings is situated on an elevated site that slopes gently down toward the south. The Rotunda, which originally housed classrooms and the library, is located at the heart of the complex at the northern end of the central green space, called the Lawn. Two rows of five pavilions, each connected by dormitory rooms, form the east and west sides of the Lawn on either side of the Rotunda. Behind each row of pavilions is a row of three hotels, which were built as eating facilities, and connecting dormitory rooms. Between these inner and outer ranges are gardens bounded by serpentine walls.

The ten pavilions are numbered I to X. Odd-numbered pavilions are on the west, and even-numbered pavilions are on the east. The lower the number of the pavilion, the closer it is to the Rotunda. Each of the pavilions originally housed one of the university's ten original, separate schools. Each contained classrooms and the professor's living quarters. The professors lived on the upper floors and taught their classes on the lower floors.

The pavilions are connected by a continuous colonnade, which offers shelter from the weather and partially screens the dormitories from public view. The walkway on the colonnade roofs connects the second-floor levels of the pavilions and is reserved for the private use of the faculty and their families.

Each of the pavilions was designed by Thomas Jefferson with elements drawn from classical models as published by Andrea Palladio, Roland Fréart de Chambray, and Charles Errard. Each is different, thereby offering a separate lesson in classical orders and architecture.

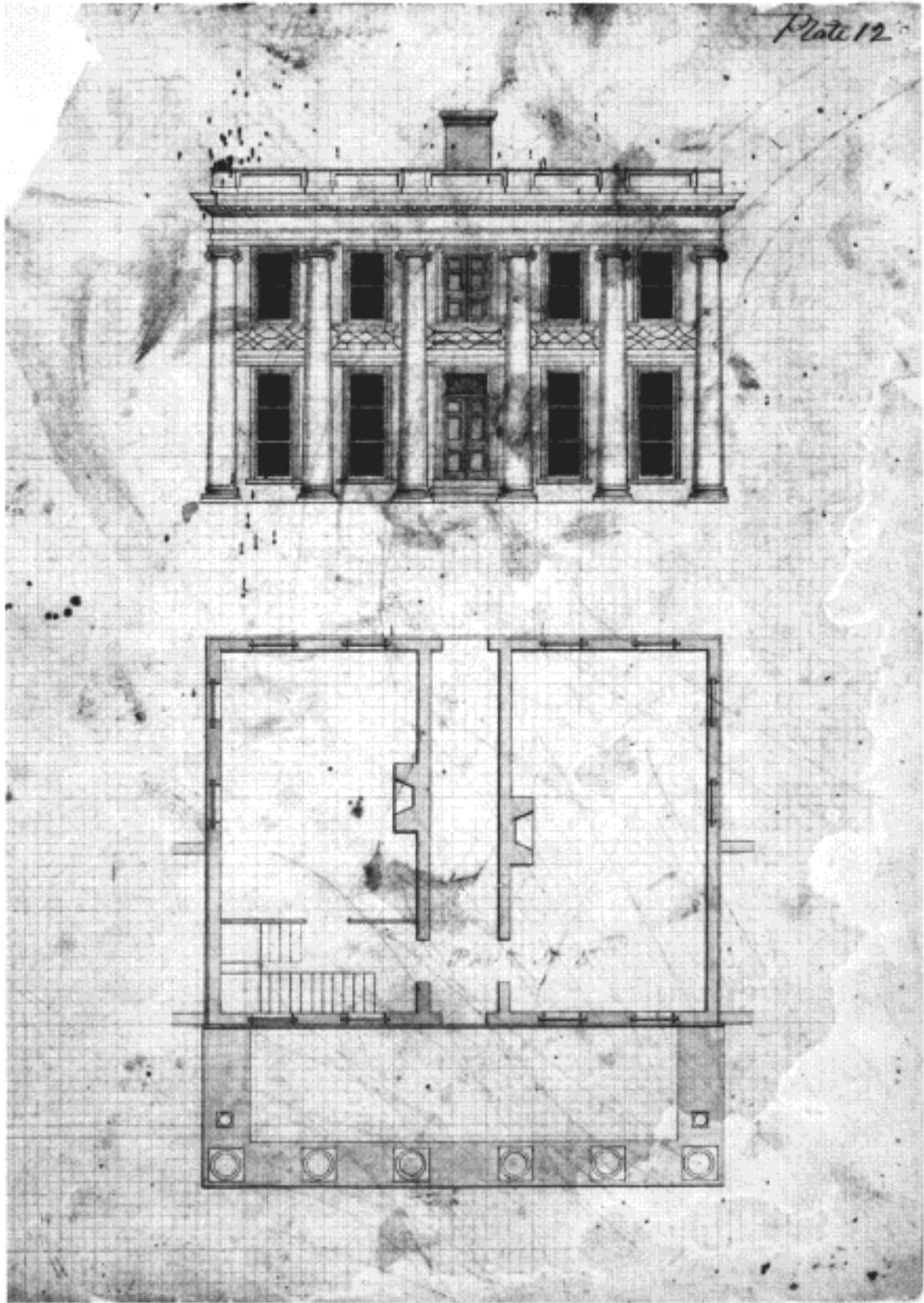

*Elevation and plan of Pavilion V, attributed to  
Cornelia Jefferson Randolph or John Neilson, c. 1820*

# PAVILION V

## HISTORY

### AUTHORIZATION AND NEGOTIATION FOR CONSTRUCTING PAVILION V

**A**t a meeting on October 7, 1817, the Board of Visitors of Central College, the predecessor of the University of Virginia, voted to proceed with the construction of two more pavilions and their adjoining dormitories; work on Pavilion VII had begun during the summer of 1817. While the board authorized that this work “be contracted for and executed” in 1818, work on only one pavilion, which became known as Pavilion III, was begun in accord with that schedule. Construction of the other structure, later called Pavilion V, was not started until the summer of 1819.<sup>1</sup>

In order to proceed with construction during the 1819 building season, Jefferson had requested that the Board of Visitors hold a special meeting in February, 1819, rather than wait for the regular meeting on March 29. Otherwise, Jefferson told his fellow Visitor, Joseph Cabell, they would “lose the chance of employing workmen, & consequently lose a year in our preparation.” “I think with you,” he continued, “that we must apply all our funds to building, for the present year, and not open the institution until we can do it with that degree of splendor necessary to give it a prominent character.” Toward that end Jefferson proposed that the Visitors “must defer the mission for professors to another year” and turn their attention instead to determining “at once what buildings we can undertake this season & to engage undertakers.” He believed that the current funding would permit the construction of two more pavilions, a hotel, or refectory, and twenty to thirty more dormitories.<sup>2</sup>

At the meeting held on February 26, 1819, the Board of Visitors decided, as Jefferson had hoped, to apply all funds not needed for other purposes to “providing additional buildings for the accommodation of the Professors, & for dieting &

West.  
 Pavilion No. 5 Palladio's Ionic modillion order  
 front  $44\frac{1}{2}$  height  $27\frac{1}{2}$  order entire  $10\frac{1}{2}$  gives module  $2\frac{1}{2} = 30$   
 Column base - - -  $8 - 30' = 1 - 3$   
 shaft - - -  $8 - 7\frac{3}{4} = 20 - 3\frac{3}{8}$   
 Capital & listel  $0 - 22\frac{1}{2} = 0 - 11\frac{7}{8}$   
 $9 - 0 \times 2\frac{1}{2} = 22 - 6 = 22 - 6$   
 Entabl. Architrave - -  $36 = 1 - 6$   
 frieze - - -  $27 = 1 - 1\frac{1}{2}$   
 Cornice - - -  $45 = 1 - 10\frac{1}{2}$   
 $1 - 48 \quad 4 - 6 \quad 4 - 6$   
 projection of Cornice  $45' = 22\frac{1}{2}$   $27 -$   
 dimin. diam.  $52\frac{1}{2} = 26\frac{1}{2}$  mod. 30. 1. minute =  $\frac{1}{2}$  1.  
 from Cent. to Cent. of Column  $3\frac{1}{3}$  gives interval  $2\frac{1}{3}$ , the Euclyde being  $2\frac{1}{2}$  mod  
 $3\frac{1}{3} \times 5 + 1 = 17\frac{2}{3} \times 30 = 530 = 44 - 2$  breadth of front.  
 Spacement of windows in moduly  $2\frac{1}{2} + 2\frac{1}{2} + 3\frac{1}{2} + 3\frac{1}{2} + 3\frac{1}{2} + 2\frac{1}{2} = 17\frac{2}{3}$  mod  
 in feet  $11.5 + 0.4 + 0.4 + 0.4 + 0.4 + 5.5 = 42.2$

the whole height above the Zockle is  $27\frac{1}{2}$   
 the upper joists are above and upon the Cornice  
 the Middle joists  $1 - 0$   
 floor above the Zockle  $2 - 0$   
 leaving clear pitch for 2. rooms  $24 - 0$  or  $12\frac{1}{2}$  f. each.

$27 -$   
 exterior entablature - - -  $4 - 6$   
 from bottom of entabl. to upper floor  $7 - 6$   
 pitch of Upper rooms - - -  $12 - 0$   $12\frac{1}{2}$   
 middle joists & floor - - -  $1 -$   
 between joists & lower floor. - -  $12 -$   
 from lower floor to Zockle a descent of  $2 -$   $15$  }  $27\frac{1}{2}$   
 from ceiling of kitchen to Zockle  $1\frac{1}{2}$  f. to floor of kitchen  $\frac{1}{2}$  f. to founda  $\frac{1}{2}$  f. =  $1\frac{1}{2}$  f.  
 which gives to the kitchen a clear pitch of  $8\frac{1}{2}$  f  
 from the Zockle to the Upper floor being  $15\frac{1}{2}$  f  
 deduct the Tuscan of the Colonnade  $11\frac{1}{2}$   $7.06$   
 leaves from upper floor to terras of Dormit. descent  $3 - 4.04$  by steps.

## HISTORY

lodging the students of the University." The Visitors also agreed to proceed with entering into "engagements" for "building in the approaching season two more pavilions for the Professors one Hotel for dieting the students, and as many additional Dormitories for their lodging, with the necessary appendages as the said funds shall be competent to accomplish."<sup>3</sup>

In order to generate the needed proposals from workmen, the Board of Visitors placed advertisements that set forth the terms for construction and requested proposals from "Brick Makers and Brick Layers, Stone Masons, House Carpenters and Joiners, Plaisterers, Painters and Glaziers, who can produce certificates from known characters for their perfect skill in their line of business of their good faith and punctuality in the performance of their undertakings."<sup>4</sup> Their terms set forth in the advertisement pertained to the construction of Pavilion V as well as to the other pavilions begun in 1819:

*Brick Makers and Brick Layers* — It is proposed to lay about a million of bricks this season in buildings so far distinct that the undertakings may be in one or more portions of about an hundred thousand bricks each, the undertakers finding materials as well as work. The front walls are to be faced with oil stock bricks; the others with sand stocks, the interior mass to be of place bricks — all to be laid with good bond, to be clinkers, and not a single sammel brick to be used in any part of the work, under a penalty of five cents for every such brick, nor more than 2 bats to 9 whole bricks; the inner mortar to be  $\frac{1}{3}$  lime and  $\frac{2}{3}$  clean gritty sand, without any mixture of earth; the outer  $\frac{1}{2}$  lime and  $\frac{1}{2}$  such sand, and the whole to be grouted with a mortar of the inner quality. In estimating the number of bricks which are to be the usual dimensions, one half of the openings both as to materials and work, are to be deducted. The lime kilns are about 9 miles distant along the public road, and the price of lime has been generally about 16 cents the bushel at the kilns; but it is believed that better lime, and on better terms, may be had from more distant quarries. Good sand is two miles distant. The wood lands commence at about half a mile, and the brick yard with water is about 30 to 40 rods distant: space for the yard, earth for the bricks, sand for the mortar, and water for both will be given. Each undertaker is to say what portion of this work he will contract to execute by the 1st day of October next, at what price for the brick, and what for the other materials and work.

*Stone Masons* are to say for how much they will lay the stone and [mud?] the mortar and grout of the composition before mentioned, leaving the quarrying and hauling for a particular arrangement. The quantity of this work to be done is about 300 perch.

*House Carpenters and Joiners.* — As the items of house carpentry and joinery and their several prices are too numerous to be specified, some standard of refer-

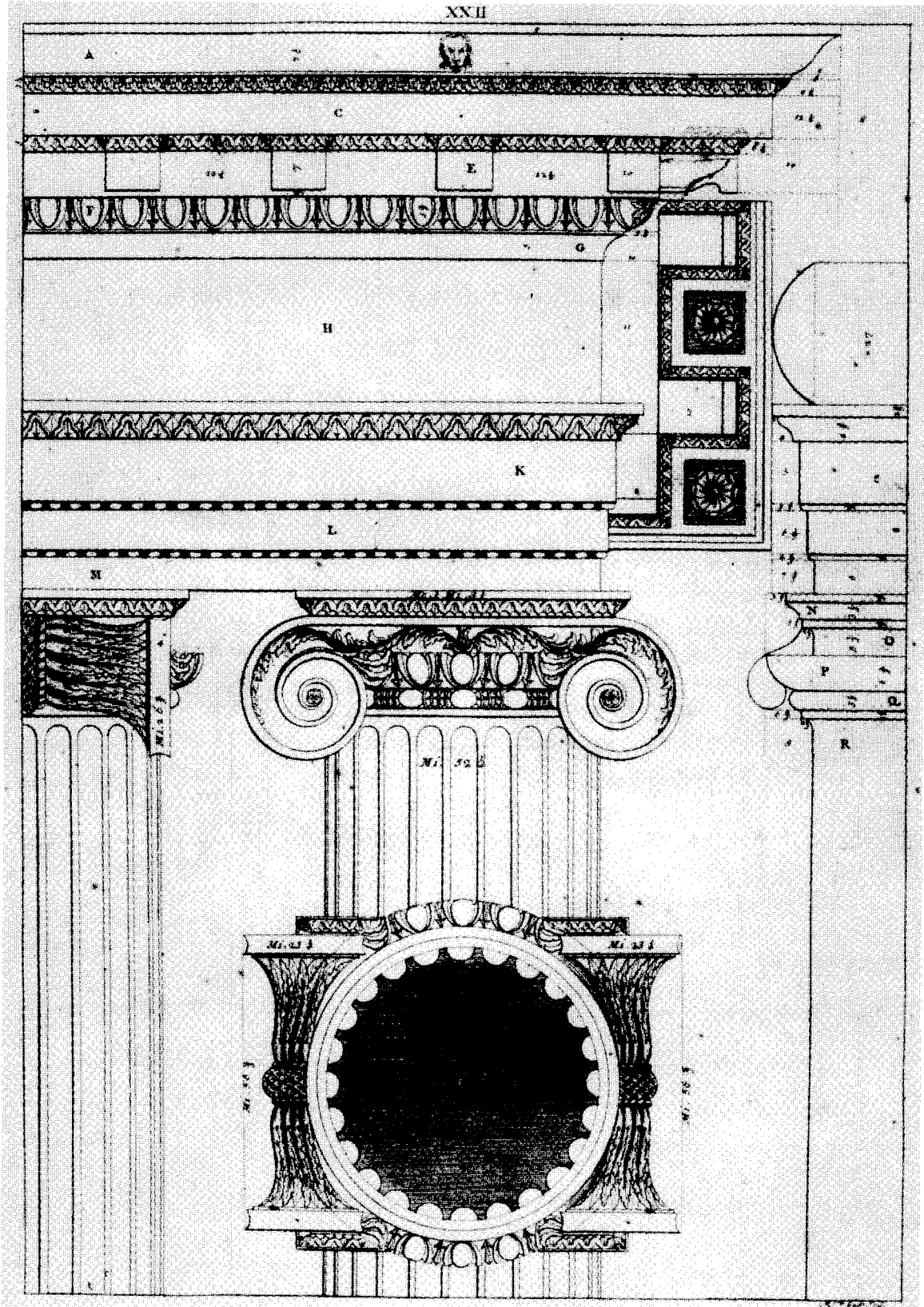

*Ionic of Palladio from Four Books of Architecture  
by A. Palladio, Leoni edition, 1721.*

## HISTORY

ence for prices must necessarily be proposed, the Philadelphia house carpenter book of prices, printed by M. Carey, in 1812, is adopted for the rule of prices; and every undertaker is to say whether he will undertake at the prices printed in that book, or at what percent, more or less. Lumber is expected from this reference to be settled at its actual cost; the uncertainty of which might be hazardous for the undertaker; but unseasoned boards must be sufficiently kiln dried by him. Where the item of work and price is not to be found directly in the price book, it is to be deduced from the elements furnished by other articles in the book. — As the buildings are distinct in portions of a little more or less than one thousand bricks, each undertaker is to say of how many of these portions he will contract to finish the wooden work by the 1st day of February next.

*Plasterers, Painters, and Glaziers*, may state the several items and prices in their line for which they will work, or they may refer to the Washington price book, published by Evans, and printed there in 1804. . . . Stating whether they will undertake at the printed prices, or at what percent, above or below these.

The undertakers in every line are to execute with exactness the general plan and instructions which will be exhibited to them. Making their own working draughts, however, and submitting them to previous examination; the brick and wooden work is to be done as neatly and substantially as the best specimen of what is already done at the same place, and all other work in the very best manner. Whenever work is not finished by the day stipulated, the party is failing to pay as an idemnification, a rent of 10 per cent. on the cost of the building from the day stipulated until his part of the building is finished. Advances of money will be made from time to time to the amount of materials bro't into place, and of half the workmanship actually done; the balance within six months from the completion of each portion.<sup>5</sup>

Just a few days after the advertisements appeared, workmen began submitting proposals and letters of recommendation to Nelson Barksdale, the proctor of the university. Among them were two men who initially applied individually but ended up working together on Pavilion V — John Perry and James Dinsmore.

John Perry must have been very familiar with the university's building program, for he had already supplied brick for Pavilion III and had worked on Pavilion VII, the first to be constructed. He was also well known to Jefferson, for he had also worked at Monticello and at Poplar Forest, Jefferson's summer home near Bedford, Virginia.<sup>6</sup> Perry's proposal, prepared on March 27, 1819, was among the first to be submitted:

I would Contract to furnish all materials and lay 300,000 bricks at \$14 per thousand — according to the Specimen furnished in the Corinthian pavillion [III], which tho undertaken by M. Brown was actually executed by me and a further



front 22-2 height 27 = order-culine of 10-20. which gives a module of 2-6 and 1 = 2-2.

Column base	0-30	=	1-3	
shaft	0-7 3/4	=	20-3 3/4	
Capital & helix	0-22 1/2	=	0-11 1/4	
	9-0		22-6	22-6
Entablature architrave	3-6	=	1-6	
Frieze	2-7	=	1-12	
Cornice	4-3	=	1-10 1/2	
	1-20	=	4-6	4-6
				27

projection of cornice 2 1/2 = 2 1/2 x  
diminished diameter 5 3/8 = 2 6/8

from center to center of columns. 3 1/2 gives intercolumnations of 2 1/2 the eustyle being 2 1/2  
 $2 1/2 \times 0 + 1 = 17 1/2 \times 30 = 520 = 22-2$  the whole breadth of the front.

Spacing of windows in Modules  $2 1/2 + 2 1/2 + 2 1/2 + 2 1/2 + 2 1/2 + 2 1/2 = 17 1/2$  mod  
 in feet & inches  $5-5 + 0-6 + 0-6 + 0-6 + 0-6 + 5-5 = 22-2$

---

The whole height above the Zocle is 27-1  
 The upper joists are above and upon the Cornice  
 The middle joists - - - - - 1-0  
 floor above the Zocle - - - - - 2-0  
 leaves clear pitch for 2 rooms  $\frac{22-0}{27}$  or 12-f. each

---

entablature	4-6	
from bottom of entablature to upper floor	7-6	
pitch of upper rooms	12-0	12-0
Middle joists & floor	1-0	
between joists and lower floor	12-0	
from lower floor to Zocle a descent by steps of 2	15-0	27-0
		27-0

from the ceiling of the kitchen to the Zocle is 1-f } 0-f for clear pitch of kitchen.  
 to the floor of the kitchen 7- }  
 to the foundation - - - - - 2- }  
 10-f

from the Zocle to the upper floor being 15-f.  
 deduct the Tuscan Columnade - - - - - 11-7-86

leaves from upper floor to terrace of Bernini's a descent of 3-2-12 by steps.

Thomas Jefferson's notes and specifications for Pavilion V, 1819

## HISTORY

specimin exhibited in the two ranges of dormitories appendant to the Doric pavillion No. 4 [now VII] — If it should be required I will even bind myself to execute the work in a neater Style than that already done without affecting its substantial strength — I would further Contract to execute the wood work appendant to the laying of the 300,000 bricks mention in the proposal above according to the specimin exhibited in the wood work of the doric pavillion No. 4 — at a rate of 25 pct. above the printed prices in M Carys philadelphia price book that making the prices virginia Currency — I would further contract to furnish all the lumber for the wood work to be executed by myself at the prices already furnished the proctor which are the Identical prices at which I have furnished lumber at Since I became the owner of a Saw mill. The lumber to be measured and received by the proctor or agent at the mill.<sup>7</sup>

The remainder of his proposal made it clear that he understood that the new work would be done under more competitive conditions than in the past. He also seemed more interested in undertaking some of the other buildings rather than another pavilion:

I have in the above proposals for work adopted a scale of prices lower than usual under the impression that from the great Competition the whole of the work will actually be undertaken at rates lower than heretofore. Should my proposals be received I would prefer to become the undertaker of the hotel and dormitories appendant thereto — oil stock brick @24\$ pr M [thousand]. Kiln drying plank is expected to be paid for what it shall be worth.<sup>8</sup>

James Dinsmore also submitted a proposal on March 27, 1819, and in it he expressed his concern about the investment he had already made in the university, where he had been at work since 1818 on Pavilion III. Unlike Perry, Dinsmore directed his proposal specifically to the construction of Pavilion V:

As I have fixed myself with a work Shop and other Conveniencys, for carrying on work at the Central College and have declined other jobs, through that Expectation — it would be my desire to undertake at the University, provided I Can do it with any Probable prospect of not losing by it — From my knowledge of the manner in which the work is Expected to be executed, and the difficultys we Labour under here in procuring good workmen and also in the difference of Materials between here and Philadelphia — I should not consider Myself Justifiable in undertaking by the Book mentioned as the Standard at a less advance than the difference of the Currency between Pennsylvania & Virginia — Should it be more agreeable to the Visitors, I would undertake at five per cent less Provided they get an experienced Philadelphia measurer to measure the work after it is executed, which would Probably be best also for Preventing disputes between the Visitors & undertakers at these Rates. I Should wish to undertake the

## PAVILION V

Carpenter & Joiners work of the Ionic Pavillion (proposed to be Built between the Doric & Corinthian at which I am now engaged) with the Range of Dormitorys — attached to them, altho I had considered the Dormitorys attached to the Corinthian Pavillion as engaged under a former Contract.<sup>9</sup>

Dinsmore added in a postscript that “Kiln drying when Necessary is expected to be paid for.”<sup>10</sup>

Dinsmore was one of Jefferson’s most trusted and talented workmen. In his proposal to the University, Dinsmore requested that “as to my qualifications and fidelity in performing my Contracts I Beg leave to refer to Mr Jefferson and Mr Madison haveing worked a considerable time for Both of them.” Jefferson called Dinsmore and Perry “house joiners of the first order.”<sup>11</sup>

Meanwhile, as Perry and Dinsmore were preparing their proposals, Richard Ware arrived in Charlottesville with a letter of introduction from Robert Mills to his friend Jefferson. On March 26, 1819, the day before Perry and Dinsmore submitted their proposals, Ware made a written offer to work at 15 percent below the prices listed in the price book published by M. Cary in Philadelphia that the Visitor’s advertisement had cited as the standard. Word of Ware’s discounted price may have been circulating among the Virginian contractors, for on April 1 Dinsmore and Perry wrote to the proctor of the university that various circumstances “have induced us to believe we shall be able to procure [journeymen and laborers] on better terms and thereby be enabled to undertake at lower prices.” They consequently asked for “leave to withdraw our Respective proposals heretofore made and in Lieu thereof propose to undertake the wood work... at the prices in the Book Mentioned as the Standard and the Brick work at the prices Genl Cocke paid.” Jefferson believed that Ware’s visit had precipitated the new proposals from the Virginia contractors. He explained to another Visitor that “an undertaker came on to see the extent of the work we had to do. This brought our own people down to the same prices.”<sup>12</sup>

Jefferson was eager to award the contract for Pavilions I and V to Ware because Jefferson greatly admired the excellent craftsmanship apparent in Philadelphia buildings. On April 9, 1819, Jefferson wrote to Ware awarding him “the work to be done for the University this season” and explaining as well that “there will be as much to do the next year and much for a considerable time afterwards.” He also told Ware that “we give up the discount of 15. percent below the printed prices in Carey’s book, because we wish our workmen to receive a reasonable living price

## HISTORY

for what they do.” “But we accept” Jefferson continued, “on the condition that you can engage in Philadelphia brick makers & bricklayers to do the brickwork & that part of which you will do the carpenters work.” He asked Ware to reply immediately, for “the advance of the season & quantity of work to be done leaves us no spare time.” A few weeks later, when he learned that Ware had been “arrested by his creditors & was in jail” rather than on his way to the university, Jefferson directed the new proctor, Arthur S. Brockenbrough, to keep this news “a profound secret until we can substitute contracts to supply [Ware’s] place” and to “have written articles signed by all your workmen, for they will endeavor to fly the way when they suspect that the Philadelphia competition is withdrawn.”<sup>13</sup>

Brockenbrough followed Jefferson’s directions. It appears that within the next two weeks he settled on a contract to erect Pavilion V. “The brickwork and wooden work” were “engaged to Dinsmore and Perry.” Meanwhile, though, Ware had been set free and was at Monticello on May 28. Jefferson, again thrilled at the prospect that superior Philadelphia craftsmen could be employed at the university, told Ware that while some of the work had most likely been engaged, “enough” for him “would be still disengaged.” In the end, however, it was agreed that the Virginian workmen continued to be assigned “the completion of the Western range,” including Pavilion V, and Jefferson boldly decided to award Ware contracts for Pavilions II and IV, even though the Visitors had not yet authorized construction of any pavilions in the eastern range.<sup>14</sup>

The contract for Pavilion V evidently continued to be discussed, for Jefferson wrote in late June, 1819, regarding the bricks that “Mr. Perry is entitled to what we agreed to, not what he proposed. We agreed that Genl. Cocke’s bargain with Whately should be ours. That was that he was to find all and do all for 11 ¼ D. but there were some little modifications which I thought made it equivalent to 11 ½ D. He agreed to it.” Jefferson also affirmed the scope of the work: “in Perry’s case a single pavilion only is engaged without dormitories or any thing else.”<sup>15</sup>

In July, 1819, Jefferson predicted that once the Philadelphians were on hand, “we shall have about 100. persons at work on the different buildings.” As work began on Pavilion V, the Lawn was flanked by partially completed pavilions and dormitories. At Pavilion I workers were busy laying the basement walls, while at Pavilion III Dinsmore was “putting up the Modillions on the Cornice.” Pavilion VIII had been under construction since 1817. At Pavilion II on the east side of the Lawn, Ware’s men were laying the foundations.<sup>16</sup>

## PAVILION V

### DESIGN OF PAVILION V

Like the other structures facing the Lawn, Pavilion V was designed by Jefferson. His drawings for Pavilion V, executed on grid paper, include an elevation and plans of the basement and first and second floors. Although the elevation shows the major elements of the pavilion, the roof balustrade, or parapet, is not developed, and the Chinese lattice railings are missing. The drawings must have been meant to convey the general idea of the pavilion but not the details; doors are not delineated in the elevation, for example, and the window sashes are not fully articulated.

A second drawing, attributed to John Neilson, corresponds closely to Jefferson's, but exhibits more detail. A parapet, apparently constructed of wood panels, appears above the cornice, and there are six-panel stile-and-rail doors at the first and second floors. Three steps lead to the main entrance, which is surmounted by a fanlight set into a rectangular transom. The first-floor windows have triple sash with six lights per sash. Chinese lattice railings are shown at the second-floor balcony. Neilson's drawing of the first-floor plan is very similar to Jefferson's. The original construction of the pavilion followed Jefferson's plans closely; there are a few differences in the location of doorways in the basement and first floor, two windows in the basement, and treads of the main stair.

Jefferson intended that the second-story rooms be heated by stoves, but fireplaces were built, perhaps incorporating stoves.

The general arrangement of the spaces in the pavilions had been set in Jefferson's mind since at least 1810, when he explained that there would be "a small and separate lodge for each professorship, with only a hall below for his class, and two chambers above for himself." Later he wrote that "On the probability that such of the professors as are married will want more than 2. rooms, we leave the back side of our pavilions without windows so that we can add 2. or 3. rooms at will."<sup>17</sup>

In letters written during the spring of 1817 to architects William Thornton and Benjamin Henry Latrobe, Jefferson explained that because the pavilions would "show themselves above the dormitories," they should be "models of taste and good architecture, and of a variety of appearances, no two alike, so as to serve as specimens for the Architectural lecturer." By August, 1817, he had determined that for Pavilions III and V, "the 2. to be erected in the next year, one will have it's upper story Ionic, the other Corinthian." "The succeeding ones," he explained to Latrobe, "may exhibit the best variations of the Doric, Ionic and Corinthian." For Pavilion V, Jefferson chose the Ionic order shown in "Palladio's Ionic modillion

## HISTORY

order” from an edition of *The Architecture of A. Palladio in Four Books*, published in London by Giacomo Leoni.<sup>18</sup>

### CONSTRUCTION WORK AT PAVILION V

On August 9, 1819, George W. Spooner, Jr., who was assisting the proctor, prepared a report of the university, in which he noted that at Pavilion V “Mr Perry will commence as soon as they have succeeded in blowing a rock which has impaired there progres in diging his foundation.” The rocks apparently caused a delay of several more days, for Spooner wrote on August 20 that “we find considerable difficulty in opening the foundation of Mr. Perry’s building, being obliged frequently to blow the Rocks which is considerable Labour.” Spooner also asked the proctor “to send up,” probably from Richmond, “Twoo pair of sawyers for getting Mr Perry’s timber.” In addition Spooner related Perry’s proposed terms, “which he submits to you viz all his Joists, sills, Plates measuring side & edge Girders measuring all round @ 40 \$ all his prime heart Stuf for Sills Doors & Sash @ 50 \$ delivered to the Pitts.” Spooner wrote that Perry “will also take one of you’re hands @ 15\$.” “I expect,” Spooner continued, “he will take some of the more Inferior but this has not [been] determined on.”<sup>19</sup>

The construction of Pavilion V is generally difficult to trace, for there are few letters and few Visitors’ minutes in which its progress is mentioned. Payments listed in the proctor’s ledger, furthermore, appear to reflect when payments were made or when the bookkeeping was done rather than when construction work was undertaken. For instance, there are no payments recorded in the proctor’s ledger for 1819, even though work started during the summer, and only one payment for \$2.50 (for blacksmith’s work) was listed in 1820. A large payment to John Perry for \$1,908.84 for work done in 1820 was not posted until April, 1821, nearly two years after work on the foundation was begun. However, drafts for payments to Perry show that he received some funds in 1819, when he was paid \$158.00 for carting lumber, and in January, 1820, when he was paid \$600 for “lumber furnished for Pavilions No 3 & 5.” On June 23, 1820, Dinsmore and Perry were paid \$1,000 for “Carpenters work on Pav. 5,” perhaps for framing.<sup>20</sup>

A substantial amount of masonry work must have been undertaken between the summer of 1819 and March, 1820, for Perry was paid \$1,912.50 for brick work through March 28, 1820. According to the proctor’s journal, John M. Perry supplied the bricks for Pavilion V. The most expensive were the 10,419 oil stock bricks,

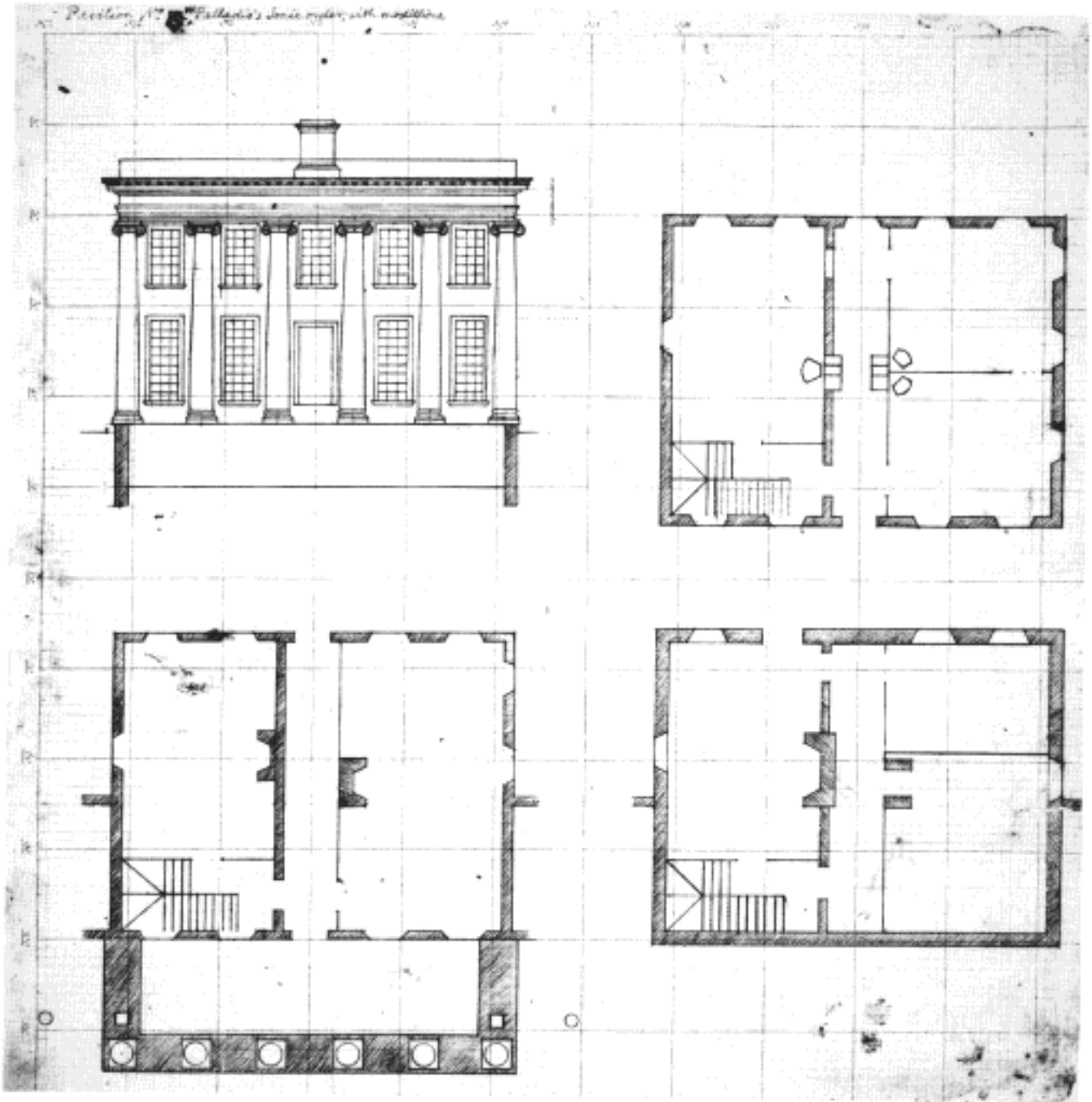

*Thomas Jefferson's elevation and plans for Pavilion V*

## HISTORY

which cost \$20 per thousand; dark red and smooth textured, they were used on the front facade. The other bricks, numbering 142,439 and costing \$11.50 per thousand, were presumably used in the foundation walls and other facades. An additional 5,428 bricks, billed at about \$11.50 a thousand, were used for the foundations of the columns of the portico.<sup>21</sup>

The largest payment for Pavilion V, the sum of \$4,623.70, was posted in the proctor's journal as paid to Dinsmore and Perry in October, 1822. It was broken down into Perry's charge of \$1,446.47, Dinsmore's bill of \$1,497.80, lumber costs of \$1,556.79, "waggonage" charges of \$91.23 and \$31.41 for out-of-pocket expenses for "scaffolding & turning." A month later, Perry was credited with \$36.79 for "bricks in back walls" (elsewhere specified for the "Garden Walls"). Dinsmore and Perry acquired for \$8.25 from Nicholas H. Lewis plank for Pavilion V in November 1822.<sup>22</sup>

The ridge-and-furrow tinplate roofing system designed by Jefferson and used on the flat roof of Pavilion V was probably installed by Dinsmore's and Perry's workers. The roof consisted of a series of ridges and valleys which Jefferson called "rooflets." The rooflets are still extant in the attic of Pavilion V. Wood boards were used to cover the rooflets; the boards directed water into the valleys, or gutters, which were covered with tinplate. Jefferson developed this roof system in imitation of the flat roofs he had seen in France, then used them extensively at Monticello, the President's House in Washington, D.C., and Poplar Forest; he enthusiastically recommended them to others. He was very interested in the roofing technology and used sheet copper, sheet lead, sheet iron, and tinplate on his roofs. In 1821 Jefferson described tinplate roofing as "the lightest, and most durable cover in the world. We know that it will last 100. years, and how much more, we do not know...all our buildings except one are covered with tin." A. H. Brooks, who installed traditional tinplate coverings on the pitched roofs of other pavilions, provided for \$67.75 "Tin Gutters & Cover to level Cornice" for Pavilion V, perhaps a reference to a device that spanned the covering and the edge of the cornice. Eight boxes of tin were used. The tinplates may have been supplied by the firm of D. M. & C. Warwick of Richmond, Virginia.<sup>23</sup>

Iron elements were also installed at Pavilion V. In June, 1820, the account for Pavilion V was charged \$2.50 for work done in the blacksmith's shop for "16 knees & 8 braces." Early in 1821 a charge of \$5 was made for "1 Crane Iron" probably for the basement fireplace. At the same time a charge of \$2.50 for "5 Rods for Portico" was posted; these rods may have been used to support the balcony. About a month



Dr. *Sonic Pavilion No 5 Meat range.* Cr

1820				1822						
Jan 21	26	To Smiths Shop	98	2	56	Nov 20	By J. K. Perry	260	19	50
Feb 22	59	"	"	7	50	" 26	" Pavilion No 7	26	2	57
Apr 9	67	" J. K. Perry	167	4	98	" "	" Balance Account	278	10	27
" 17	69	" Smiths Shop	76	"	51					
May 7	73	"	142	"	1					
" 18	77	" J. K. Perry	198	4	12					
June 28	122	" Gustings & Son	141	"	94					
July 3	125	" John Gorman	552	"	216					
Sept 21	143	" A. S. Proctor's Post	266	"	2					
Oct 20	153	" Smiths Shop	96	"	10					
Sept 21	155	" Mr. Coffee	266	"	30					
Oct 5	167	" Saml Gumpel	120	"	4					
Oct 8	21	" Pavilion 22548	69	"	2					
"	"	"	"	"	1					
" 26	148	" J. K. Perry	70	"	4					
" 29	149	" A. H. Brooke	93	"	67					
Nov 1	152	" J. K. Perry	259	"	36					
" 10	153	" Hugh Christie	142	"	1					
" 25	157	" S. G. Gausford	222	"	22					
" "	161	" J. K. Perry	259	"	158					
" "	161	" W. D. Phillips	157	"	3					
" "	168	" Lewis	222	"	16					
" "	170	" R. C. Pyle	261	"	232					
" "	171	" Pavilion No 3 Mt	52	"	4					
" "	173	" J. K. Perry	249	"	91					
" "	174	"	"	"	32					
" "	175	" Coal Expenses	74	"	28					
" "	179	" Geo. W. P. Sumner	86	"	459					
" "	"	" Anderson Madat	99	"	265					
" "	180	" Haggart's Acc't	258	"	122					
" "	181	" Trim Wash	365	"	200					
" "	182	" Labor Account	278	"	284					
					13					162
1822										
Nov 20	186	" To Stock Account	279	"	10					267
Apr 4	205	" A. S. Proctor's Post	247	"	8					25
June 10	227	" Sundries	"	"	10					50
July 15	250	" Coal & Gumpel	152	"	"					"
Sept 15	253	" A. S. Proctor's Post	258	"	5					"
" 16	250	" Maurice Gumpel	152	"	772					19
" 26	257	" S. G. Gausford	257	"	299					171
" 27	258	" J. K. Perry	269	"	20					42
					12					54
										27
										11
										27

Expenses for Pavilion V from Proctor's Ledger, 1819-1822

## HISTORY

later, a charge of 50 cents was made for six 10-inch iron spikes and \$1.00 for a baluster. In 1822 the smith's shop was paid 25 cents for a "Staple" and \$10.17 for "61 Springs for Windows." An additional charge of \$4.00 for an unspecified amount of smith's work was also made. Of the university's expenses for "Locks, Hinges, Screws, nails, castings iron &c" the sum of \$345.04 was allocated to Pavilion V. The names of the merchants who supplied this hardware were not detailed but may have included John Van Lew & Co., of Richmond, who were supplying similar hardware to the University at this time.<sup>24</sup>

The plainer stonework for Pavilion V was cut and carved by John Gorman, who made the six Ionic bases for the columns of the portico at a cost of \$29.00 each. Gorman had worked for Jefferson at Poplar Forest, where he had been responsible for "dressing and laying some hearthstones and marble slabs." Jefferson had found him "well informed, industrious, very skilful, sober & good humored" and suggested to the proctor that he would be "a valuable acquisition." Gorman, Jefferson reported, "understands the business from the quarrying to conducting the work to the outlines for the sculptor." The columns may have been built after the front facades, for John Gorman was not paid for carving the bases of the columns until July, 1822, and Perry was paid \$411.89 "for brick work in Columns &c" in November, 1822. The capitals themselves were not installed until 1823; in the interim, blocking was presumably installed to support the entablature and roof. Gorman also cut and set "1 Front & 2 plain Sills" and another sill "to back steps," cut the front steps, and supplied "Coping to wall." He also provided "3 Stove Stones," probably used in conjunction with the three heating stoves on the second floor. His total bill for Pavilion V was \$216.87.<sup>25</sup>

Other masons and stone workers also worked at Pavilion V. Samuel Campbell supplied 8 perch of stone or stone work for the "area & Garden Walls" at a cost of \$4.40, a fraction of the amount he supplied for other pavilions and hotels. Hugh Chisholm, an Irish-born mason and another of Jefferson's veteran workmen, was recorded in November, 1822, as doing \$1.00 worth of "plaistering walls with cement" at Pavilion V, most likely as waterproofing. A schedule of Chisholm's rates indicates that he did both "lathing & Plaistering," as well as plastering on brick walls. In 1822 an additional charge of \$299.50 for stonework was attributed to Pavilion V, but no details were given. William B. Phillips, another mason, was paid \$3.63 for an unspecified amount of brickwork in November, 1822.<sup>26</sup>

In January, 1822, Jefferson reported to the Virginia legislature that the Visitors had completed all but one of the "ten distinct houses or pavilions containing

## PAVILION V

each a lecturing room, with generally four other apartments for the accommodation of a professor and his family, and with a garden, and the requisite family offices,” as well as six hotels and 109 dormitories. These structures were, he continued, “all in readiness for occupation, except that there is still some plaistering to be done, now in hand, which will be finished early in the present season, the garden grounds and garden walls to be completed, and some columns awaiting their capitals not yet received from Italy.” The Proctor’s records suggest that the garden work at Pavilion V was underway in 1822, but that the installation of the column capitals was not completed until 1823 and the interior plastering and painting not until 1824 or early in 1825.<sup>27</sup>

John Perry was paid \$25.55 for “2,555 Bricks in wall,” perhaps for a garden wall, and \$66 for 6,000 bricks for the serpentine garden wall. This payment was posted in November, 1822, and probably reflects the fact that work on the grounds was progressing. A charge of \$33.27 for carting may have been related to hauling the bricks. Perry provided bricks for the garden walls and areaways of the pavilions, including 1,864 bricks for Pavilion V for \$20.42 in 1823. In June 1823, he requested payment from the proctor toward the “Brickwork on privies & Garden Walls” and dispatched his son to collect the sum, for Perry was “afraid to turn out in such damp weather as I have taken a good deal of medesin latterly.”<sup>28</sup>

Initially, Jefferson had planned to have the capitals for the porticoes of the pavilions carved from stone taken from a local quarry and worked by two Italian carvers, Giacomo and Michael Raggi, for whom he had arranged passage to Charlottesville in 1819. Soon after the Raggis began working the local stone, however, they found that it was “impossible to make of it an Ionic or Corinthian capital.” Jefferson then inquired about stone from the vicinity of Poplar Forest, but found that “the quality is such as would not bear the chissel for delicate work, and is so deep a blue as would not do with our white pillars.” Marble from a quarry in Augusta County, Georgia, was investigated but also found wanting.<sup>29</sup>

In October, 1819, the Board of Visitors approved a resolution acknowledging that “it may be necessary to procure elsewhere proper stone or marble, & to have such Capitels executed here or elsewhere.” At a meeting held on April 2, 1821, the Visitors approved a proposal to have the more ornate capitals carved at Carrara, Italy. A draft for \$1,200 was quickly arranged, and on April 16 Jefferson dispatched an order with specifications for ten Ionic, six Corinthian, and two Corinthian half capitals to Thomas Appleton, the U. S. Ambassador to Italy. Jefferson hoped that

## HISTORY

the capitals would be delivered in the fall of 1821, but they did not in fact arrive for two more years.<sup>30</sup>

In a memorandum entitled "Specifications of the Corinthian & Ionic capitels wanting for the University," Jefferson ordered for Pavilion V

6. Ionic capitals for columns whose inferior diam. is 30. I. and dimind. diam. 26 1/8 to be copied from the capital of Palladio as given in his 1st Book wherein he treats of the orders in general, and its 16th chapt. in which he describes the Ionic capital particularly, the drawings of which are in plates 20.22. pa.28. Leoni's London edition, presenting volutes in front & back & ballusters in their flanks.<sup>31</sup>

Since the marble capitals had to be placed on brick rather than marble shafts, he added that "the upper end of the shaft must be subjoined" to "not only the Astragal, but a bit of the shaft itself as low as the bottom of the Volutes."<sup>32</sup>

By the late summer of 1823, the column capitals had arrived from New York in eighteen boxes, evidently each crated separately. On August 27, 1823, Jefferson wrote that the capitals "from Italy are now recd. and in the course of a fortnight will all be up."<sup>33</sup> Their installation was confirmed on September 20, 1823, when Arthur Brockenbrough wrote Jefferson that

I have the pleasure of announcing to you the arrival of the Corinthian and Ionic Capitels of Marble ordered from Italy all of which are in there proper places without the smallest accident to them except the breaking off of a small part of one of the leaves of one of the Corinthians before it was unpacked, but which has been carefully put on.<sup>34</sup>

Brockenbrough also pointed out to Jefferson that "the carving of the bead under the Ovolo of all the Ionic Capitels is omitted which would have added greatly to their beauty." Jefferson was also concerned about this omission and told Ambassador Appleton that "in the Ionic capitels from Palladio, the astragal is plain, instead of being carved."<sup>35</sup>

The cost of the six Ionic capitals for Pavilion V was posted in two payments. The sum of \$565.15, representing a quarter of the remittance sent to Italy for capitals for Pavilions II, III, V, and VIII, was posted in November, 1822. A second payment was posted in September, 1823, for \$772.19; of this amount, \$55.00 was charged for each capital, and \$70.59 was marked for "additional work for Astragal," the small, convex molding around the base of the capital. The balance of \$371.60 was attributed to the "costs of transportation &c" from Leghorn, Italy, to

## PAVILION V

New York and then from New York to Richmond and Scott's Landing near the university.<sup>36</sup>

Pavilion V appears to have been among those buildings that Jefferson had described in January, 1822, as awaiting the finishing work on the interior. The plasterwork at Pavilion V was done by Joseph Antrim. In March, 1820, he had entered into a contract in which it was agreed that he would "do all the plastering, rough casting &c" at the university. The work was to be done "in a masterly manner and as fast as may be reasonably required." The price of his work was "to be ascertained by what two of the most respectable members of the Master plasterers society of Philadelphia say is the customary & fair price at this time in that place." Measurement of the work was to follow the price book Philadelphia master plasterers. By the time he worked on Pavilion V, Antrim had done plastering at other pavilions and at Poplar Forest. Jefferson held Antrim's work in high regard, writing in a letter of recommendation in 1824 that "Joseph Antrim has been employed, as plasterer, to do the whole plaistering of all the buildings of the University of Virginia which he has executed with fidelity and a skill of the first order. He is moreover of perfectly correct habits and conduct, sober, industrious, faithful, and worthy of any degree of trust which may be reposed in him." In September, 1823, Antrim was paid \$439.96 for work at Pavilion V. Since there are no prior charges for plastering, it would seem that the plastering was not done until the 1823 building season. In February, 1825, Antrim was paid an additional sum of \$227.69 for work at Pavilion V, presumably for additional plastering.<sup>37</sup>

Lead and composition ornaments for the pavilions were ordered from William Coffee in March, 1822. Coffee, a sculptor who had done terra-cotta busts for Jefferson and supplied composition ornaments for Monticello and Poplar Forest, had emigrated from England to New York in 1816. He visited Jefferson at Monticello as early as 1818 and later corresponded with him regarding the use of hydraulic cement in cisterns at Monticello. Arthur Brockenbrough, the proctor of the university, contracted with Coffee to supply 75 ox skulls, 75 flowers, and 75 lozenges in composition for the drawing-room entablature of Pavilion V. The ornaments were to be delivered to Richmond by October 1, 1822; however, they were evidently not put up until after April, 1823. The proctor charged the Pavilion V account \$39.00 for these goods, which he calculated by dividing Coffee's total bill of \$390.14 virtually equally among the ten pavilions.<sup>38</sup>

Other ornamental elements for Pavilion V were provided by Peck and Crawford, who had also supplied the "Public Privies." For Pavilion V this firm supplied

## HISTORY

Chinese railings for four windows and for a gate, probably for the garden wall.<sup>39</sup>

The painting of the exterior trim and glazing of windows at Pavilion V was done by Edward Lowber of Philadelphia, who was also similarly engaged on the other pavilions, the hotels, and the dormitories. In September, 1823, Lowber was credited with a payment of \$289.71 for "Glass, Glazing & 2 coats Paint on sashes" at Pavilion V. In September, 1824, he was paid \$215.00, probably for interior painting, since a payment for plasterwork was made at about the same time.<sup>40</sup>

The university allocated overhead costs towards the construction of Pavilion V as follows: for "Stationary, Postage, Traveling expences, &c," \$50.46; Proctor, Bursar, Professors & Clerks Services," \$459.80; other "Waggonage cartage & Boatage," \$102.67; and other labor expenses, \$560.60.<sup>41</sup>

After the second payment was made to plasterer Joseph Antrim in February, 1825, the proctor calculated the cost of Pavilion V up to that point as totalling \$11,723.41. During the rest of 1825, a total of only \$40.68 in additional expenses was paid.<sup>42</sup>

## ALTERATIONS TO PAVILION V

In the summer of 1829, the Board of Visitors adopted a resolution authorizing the construction of "one office, with two rooms" in the rear of Pavilion V. At this time Robert M. Patterson, professor of natural philosophy, was residing there. He had succeeded George Long, professor of ancient languages, in 1828, who had moved in during 1825. Evidently this addition was constructed.<sup>43</sup>

Records indicate that some improvements and repairs were made to Pavilion V and its environs in the 1830s and 1840s. In 1833 the Visitors agreed that "if the Executive Committee should deem it expedient, they shall have an additional well provided in the back court of & in a situation convenient to the pavilions of Professors Patterson & Davis." In 1837 "a fallen wall in the back yard" of Pavilion V was to be rebuilt; three years later the Visitors gave permission "to continue the plank enclosure" in the backyard on the north side of Pavilion V "provided that the old planking, wherever requiring repair, be taken down & neatly renewed & that the whole shall be painted." In 1849 the proctor was directed "to cause such an addition or alteration to be made in the outhouse in Doct: Harrison's yard as to give him an additional room." Glessner Harrison, professor of ancient languages, had moved into Pavilion V in 1835. Harrison remained until 1859, and an important addition was made during his period of residency.<sup>44</sup>

## PAVILION V

In 1832, John H.B. Latrobe visited the university and after condemning Jefferson's architectural aesthetics also attacked the conditions of the buildings: "The whole has a shabby genteel look, and is already showing marks left by time in its frail materials. The columns are of stucco, some of the capitals and bases of wood, others imported at immense expense from Italy to be joined to brick and plaster. The mortar is peeling off in many places, showing the red bricks underneath. The wood is yawning, with wide, long splits."<sup>45</sup>

This apparent need for repairs is suggested in an item in the Visitors' minutes of 1837, when it was directed that "the Cellars in Pavilion No. 5" were to "be made dry by draining." Water must also have been a problem upstairs, for at the same time it was noted that the roof was "now in a leaky condition," and it was proposed that it be "raised and covered with slate." Evidently rather belatedly, the Visitors noted that "the Front door of pavilion No. 5 occupied by Doct. Harrison was some years ago damaged in a riot of the Students" and needed repair. The Visitors authorized the proctor in July, 1844, "to cause the front door of Pavilion No. 5 to be duly repaired."<sup>46</sup>

In the fall of 1850, Harrison and the professor of mathematics applied to the Visitors "for some additional buildings in the rear of their respective Pavilions for the accomodation of their families." There must have been a pressing need for extra space at Pavilion V, for in 1850 Harrison and his wife Elizabeth had nine children ranging in age from six months to eighteen years. The minutes record that the Visitors found the request to be "reasonable" and instructed the executive committee "to cause such additional building to be erected by the proctor upon such plan & terms as they may deem advisable & proper."<sup>47</sup>

Evidently those terms included an arrangement by which Harrison advanced the funds for construction of what became the west wing of Pavilion V and the university would then reimburse him. The wing must have been constructed within two years of the Visitors' approval, for in June, 1852, Harrison submitted "an account of advancements made by him for the addition to his Pavilion, and asking that the same be refunded." His account was referred to an inspection committee, which rather than approving or disapproving payment, decided to issue a general policy statement about unauthorized alterations and additions, which, no matter "however trivial and however conducive to convenience," they nonetheless considered to be a "mischievous tendency." They took the occasion to promote the position that "a vigilant care be taken to prevent any alterations of the buildings of the

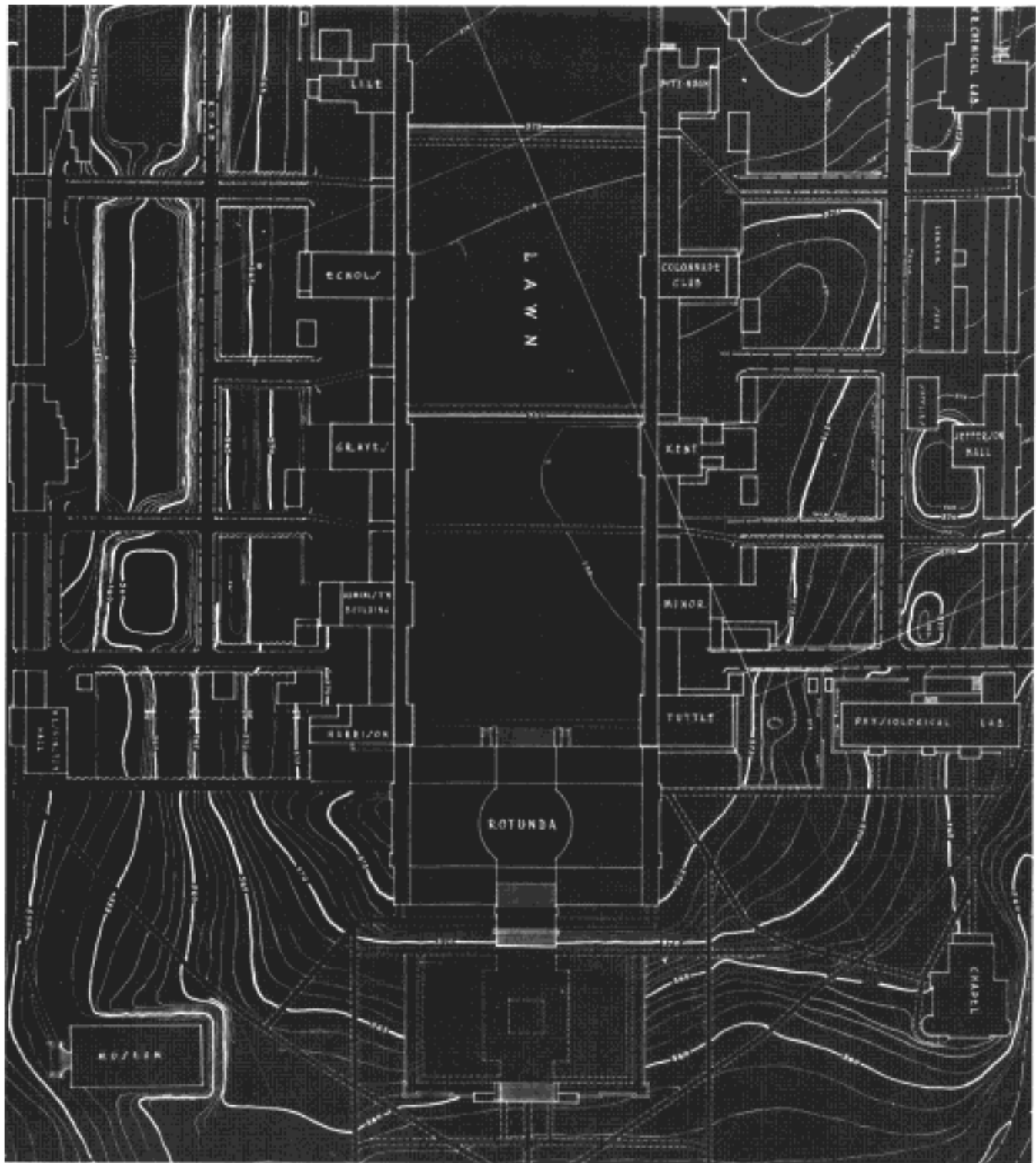

*Detail of topographic map of the university, 1909*



## PAVILION V

University, without proper authority” and warned that the university would not pay bills for unauthorized changes.<sup>48</sup>

Harrison appealed again to the Visitors in September, 1852, for reimbursement and also expressed concern about the resolution on alterations. The Visitors declined to re-examine the matter of reimbursement because they were holding a special meeting but promised to do so at their next meeting; they also made a point “to declare in justice to Dr. Harrison” that the resolution had not been intended “to cast any censure, or to reflect in any manner on the conduct of Professor Harrison.” Finally in June, 1853, a year after his initial application, the Visitors agreed to pay for “the actual cost of the addition” and to refund to Harrison the costs he had incurred.<sup>49</sup>

In 1859 Harrison resigned from the faculty after having served for what the Visitors recorded as “more than 30 years of ever increasing usefulness,” during which time he “cultivated the taste for classical learning, revolutionized methods of instruction, and raised the standard attainments.” He was invited to “continue to use his present House, until such time as it may suit his convenience to move.” At his departure, Pavilion V was to be occupied by the professor of natural philosophy, Francis H. Smith, who had been living in Pavilion VI, and Pavilion VI was to be occupied by the newly elected professor of Latin.<sup>50</sup>

During the Civil War, the university buildings suffered from neglect, and in July, 1865, a member of the building committee “reported that much of the roofing was in bad condition,” and like the skylight of the rotunda, the pavilions and dormitories “required immediate attention.” A report made three years later indicated a recurring problem with water: “The roofs of the Professors Houses, the Hotels and dormitories are said to nearly all leak more or less”; moreover, the gutters were “generally in bad condition.” A decade later the committee on buildings and grounds reported to the Visitors that “the floors covering the Colonnades on the Lawn are so much decayed as to be dangerous to walk over and almost useless to protect the walks underneath, from the weather.” “All the Buildings,” including evidently Pavilion V, were also “suffering for a renewal of external paint.” The Visitors authorized repair of the floors over the colonnades and the sum of \$1,000 for painting; presumably some of these improvements were made at Pavilion V. In the spring of 1880, painting was done at all of the pavilions; at Pavilion V, an area equal to 339 square yards was painted. At this time 269 windows were glazed; perhaps some were in Pavilion V.<sup>51</sup>

## HISTORY

In 1903, the Visitors authorized the expenditure of up to \$900 “to change and repair the pavilion now occupied by Prof. Smith, for the joint occupancy of Profs. Smith and Kent.” Kent, who taught English, had married a daughter of Smith. In 1907, Smith resigned and was appointed emeritus professor of natural philosophy. When his son-in-law, Professor Kent, died in 1917, Smith was given permission to remain at Pavilion V until September 1, 1918, rent free. Apparently there was an expectation that Professor Smith would move out in 1918, for the Visitors passed a resolution in June, 1918, providing that when that pavilion “becomes vacant,” the courtyard between it and Pavilion III would “be restored to its original state as designed by Mr. Jefferson; that the whitewashed board fence, wood shed and coal houses be removed.” The concern was that “This alley is the most prominent cross axis of the University, and in its encumbered state is very unsightly.” Smith, however, remained at Pavilion V until his death in 1928, at which time he was 99 years old and had lived in the same pavilion for nearly seven decades.<sup>52</sup>

When the Visitors met in the spring of 1929, they agreed that Pavilion V should “be converted into two residences.” The front portion, facing the Lawn, was assigned to James Southall Wilson, professor of English, and the back part to Professor C. M. Sparrow. The occupants were to “pay for electric current and heat furnished from the University’s lines” and to keep the interiors “in good repair . . . at their own expense.” A portion of the income from a bequest was to be used to pay for the conversion. Professor Sparrow resided in Pavilion V until his death, and in 1942 his section was assigned to Professor T. P. Abernethy. Wilson remained at Pavilion V until his retirement in 1951. Later that year his portion was assigned to Dr. Alfred Chanutin.<sup>53</sup>

## PAVILION V

### NOTES

The original spelling, capitalization and punctuation of these documents have been retained in quoted excerpts, except that a period has been inserted if one did not appear at the end of a sentence, and the first word of each sentence has been capitalized.

1. University of Virginia, Board of Visitors (hereafter, BV), Minutes, Oct. 7, 1817, transcript, Manuscripts Div., Univ. of Va. Library (hereafter, BV, Min).
2. Thomas Jefferson (hereafter, TJ) to Joseph Cabell, Feb. 19, 1819, Thomas Jefferson Papers, Univ. of Va. Library (hereafter, the name of this collection is omitted).
3. BV, Min., Feb. 26, 1819.
4. *Richmond Enquirer*, March 12, 1819.
5. Ibid.
6. The TJ correspondence regarding John Perry is extensive; numerous letters are indexed in *The Jefferson Papers of the University of Virginia* (Charlottesville: Univ. Press of Va., 1973). For a reference to Perry's work at Poplar Forest, for instance, see John Perry (hereafter, JP) to TJ, July 6, 1819.
7. JP to BV, March 27, 1819.
8. JP to BV, March 27, 1819.
9. James Dinsmore (hereafter, JD) to [TJ], March 27, 1819.
10. JD to [TJ], March 27, 1819.
11. TJ to Thomas Munro, March 4, 1815, Henry E. Huntington Library, San Marino, Cal. JD to [TJ], March 27, 1819.
12. Richard Ware to Nelson Barksdale, March 26, 1819. JD and JP to Nelson Barksdale, April 1, 1819. TJ to James Breckenridge (hereafter, JB), July 8, 1819.
13. TJ to Richard Ware (hereafter, RW), April 9, 1819. TJ to Arthur S. Brockenbrough (hereafter, ASB), May 17, 1819.
14. TJ to ASB, Sept. 1, 1819. TJ to ASB, May 28, 1819. TJ and Charles Cocke to Thomas Cooper, Oct. 15, 1819. TJ to Breckenridge, July 8, 1819.
15. TJ to ASB, June 27, 1819.
16. TJ to Cooper, July 11, 1819. George W. Spooner (hereafter, GWS) to ASB, Aug. 9, 1819. Proctors' Papers, Manuscripts Division, Univ. of Va. Library (hereafter, PP).
17. TJ to Trustees of East Tennessee College, May 6, 1810, quoted in Fiske Kimball, *Thomas Jefferson, Architect* (1916; reprint, New York: Da Capo Press, 1968), p. 74. TJ to Benjamin H. Latrobe, Aug. 3, 1817, quoted in Kimball, p. 190. For a discussion of Latrobe's influence on the design of Pavilion V, see Kimball, pp. 76-78.
18. TJ to William Thornton, [May 9, 1817], quoted in Kimball, p. 75. TJ to Latrobe, June 12, 1817, quoted in Kimball, p. 188. TJ to Latrobe, Aug. 3, 1817, quoted in Kimball, p. 191. TJ, Univ. of Virginia Specification Book, Univ. of Virginia Library. William Bainter O'Neal, *Jefferson's Fine Arts Library* (Charlottesville: Univ. Press of Va., 1976), pp. 248-265.
19. GWS to ASB, Aug. 9, 1819, PP. GWS to ASB, Aug. 20, 1819, PP.
20. Proctors' Ledger, 1819-25, p. 43, PP. JP, receipt, March 27, 1820, PP (Pavilion V was called by its earlier name, Pavilion III). Statement showing where to find the vouchers, Sept. 14, 1819, May 14, 1823, PP. JP, receipt, Jan. 28, 1820, PP.
21. Proctors' Journal, 1819-28, pp. 77, 67.
22. Proctors' Journal, pp. 148, 160, 152, 158. Building accounts for the original buildings (hereafter, BA), Proctors' Records, Box 17, p. 43. In 1822, Perry was credited with a payment of \$158 for hauling lumber; this may have been the date when the 1819 charge was posted rather than a new charge.

## HISTORY

23. TJ to Charles Yancey, July 23, 1821, quoted in Kimball, pp. 193-194. Proctors' Journal, p. 149. BA. Invoice, D. M. & C. Warwick to ASB, July 27, 1823, PP.
24. Proctors' Journal, pp. 26, 59, 69. BA. See for example, John Van Lew & Co. to ASB, April 10, 1821; June 18, 1821; Aug. 2, 1821, PP.
25. TJ to ASB, Aug. 17, 1819. BA. Proctors' Journal, p. 43.
26. Proctors' Journal, pp. 147, 153, 161. [ASB], Memo of Hugh Chisholm's Prices for Plastering, [1819]. BA.
27. *Richmond Gazette*, Jan. 10, 1823.
28. Proctors' Journal, pp. 173, 43, 258. BA. Receipt, Lil[baum] P. Perry, June 27, 1823, PP. JP to ASB, June 26, 1823, PP.
29. TJ to JB, July 8, 1819. TJ to JB, July 29, 1819. Building receipts for Pavilion II, 1820, PP.
30. BV, Min., Oct. 4, 1819. TJ to Cocke, April 9, 1821. TJ to Thomas Applebaum, April 16, 1821. Receipt, A. Garrett, April 13, 1821, PP.
31. TJ, Memorandum on Capitals for the University, July 4, 1823.
32. Ibid.
33. Bernard Peyton to ASB, Sept. 18, 1823, PP. TJ to E. S. Davis, Aug. 27, 1823.
34. ASB to TJ, Sept. 20, 1823.
35. ASB to TJ, Sept. 20, 1823. TJ to Applebaum, Oct. 8, 1823.
36. Proctors' Journal, pp. 170, 26. A Bill of the Cost of 4 Corinthian Capitals . . ., July 3, 1823, PP. ASB, Memo on Capitals, July Aug., 1823, PP.
37. Contract, ASB and Joseph Antrim, March 22, 1820, PP. TJ, Sept. 25, 1824. Proctors' Journal, p. 49.
38. Agreement, ASB and William J. Coffee, March 18, 1822, PP. Coffee to ASB, April 19, 1823, PP. Proctors' Journal, p. 26. For biographical information on Coffee see Bradford L. Rauschenberg, "William John Coffee, Sculptor-Painter," *Journal of Early Southern Decorative Arts*, 4 (Nov., 1978), pp. 26-48.
39. Proctors' Journal, p. 159.
40. Proctors' Journal, p. 257.
41. BA.
42. Proctors' Ledger, p. 49.
43. BV, Min., July 20, 1829.
44. BV, Min., July 19, 1833; Aug. 18, 1837; July 7, 1840; July 29, 1849. The term "outhouse" may have meant an outbuilding.
45. John H. B. Latrobe to [?], Aug, 1832, in John E. Semmes, *John H. B. Latrobe and His Times* (Baltimore: Norman Remington Co., 1917), p. 247.
46. BV, Min., Aug. 18, 1837; July 4, 1844.
47. BV, Min., Sept. 25, 1850.
48. BV, Min., June 28, 1852.
49. BV, Min., Sept. 20, 1852; June 28, 1853.
50. BV, Min., June 28, 1852.
51. BV, Min., July 6, 1852; June 27, 1877. Proctors' Ledger, 1879 80, entry for G. I. Bowyer.
52. BV, Min., Nov. 10, 1903; Nov. 27, 1917; Dec. 28, 1917; June 10, 1918; April 30, 1929.
53. BV, Min., April 30, 1929; March 17, 1931; May 5, 1937; June 12, 1942; June 8, 1951; Oct. 12, 1951. See also BV, Min., Dec 14, 1951, and March 14, 1952, for discussion of care by both occupants.

# PAVILION V

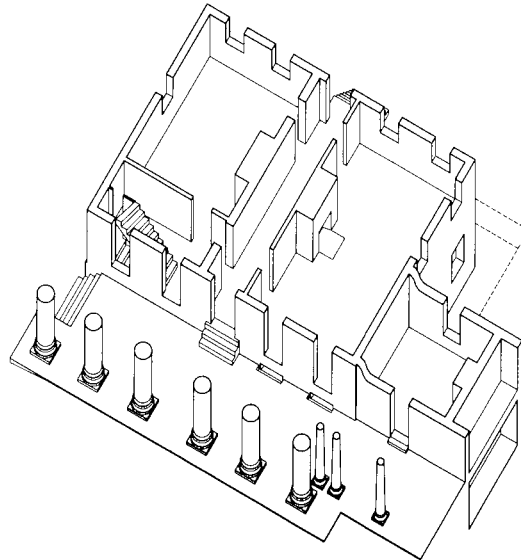
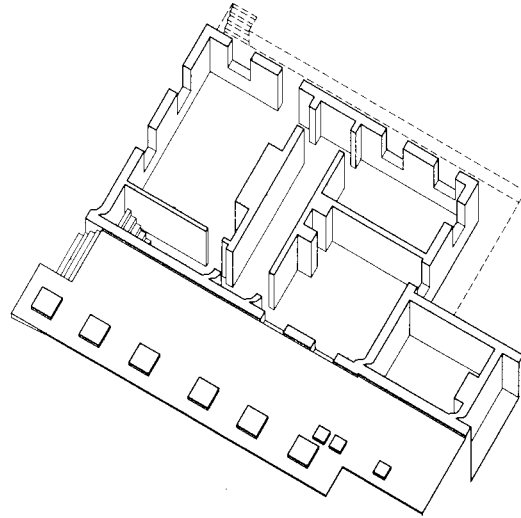

## HISTORY

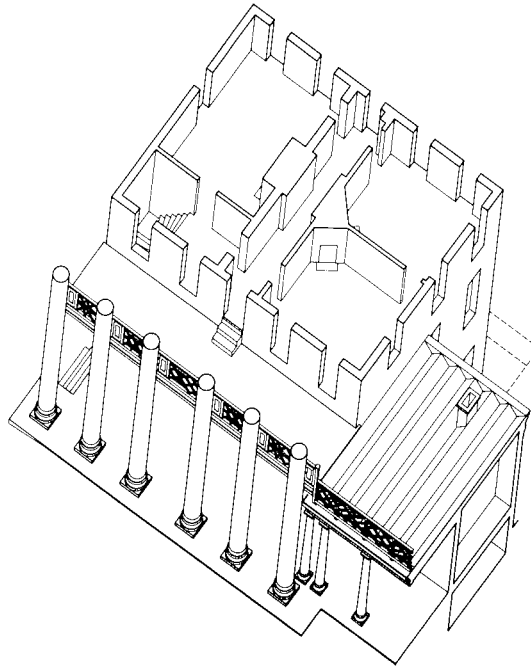

1819-1823

*Top left, basement after completion of the pavilion circa 1819-23. The basement, as constructed, was nearly identical to the Jefferson floor plan. The large room was used as the kitchen.*

*Bottom left, first floor after completion of the pavilion. The large room was used as a lecture space. The smaller room was the professor's dining room or study.*

*Above, second floor after completion of the pavilion. The three rooms were used as living quarters. The only access to the attic was through a hatch in the central hall ceiling.*

# PAVILION V

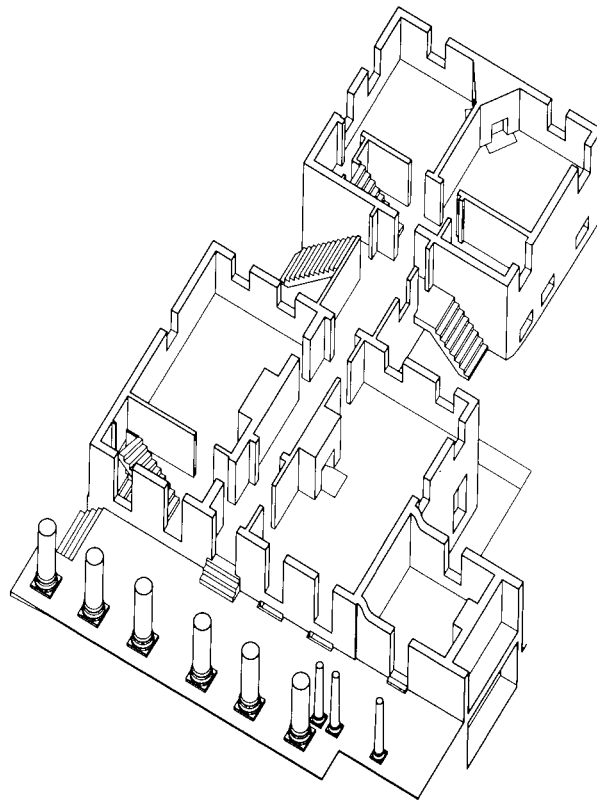
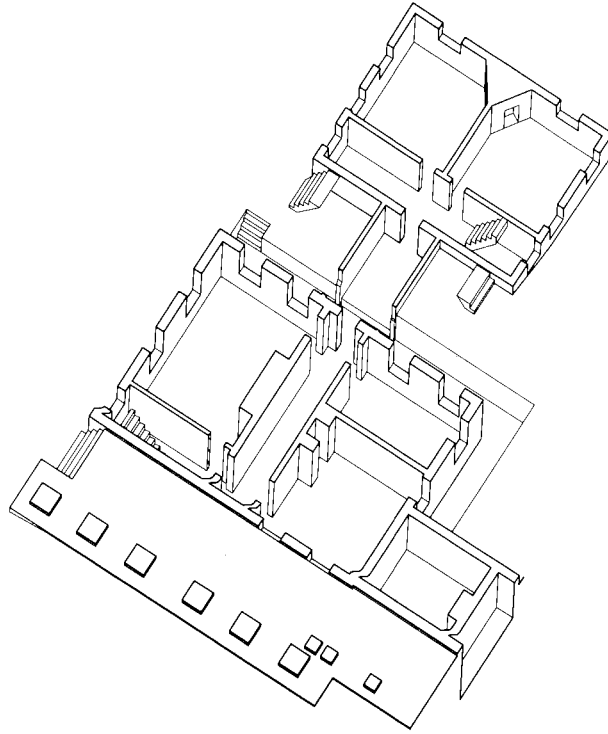

## HISTORY

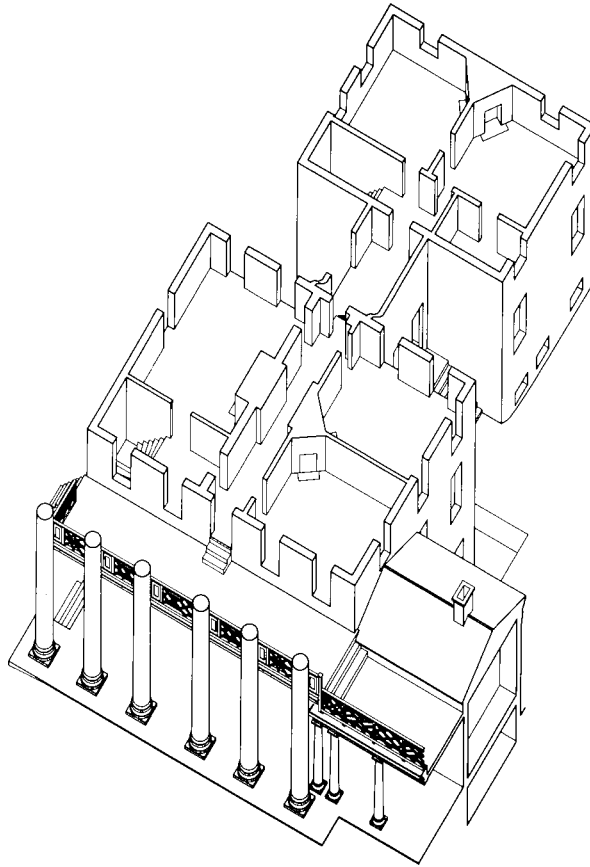

1850

*Top left, basement after completion of the circa 1850 rear addition. Access to the new hyphen was through a door in the west end of the central hall; the original kitchen door became a window.*

*Bottom left, first floor after completion of the circa 1850 rear addition. The hyphen had north and south entrances, with stairs descending from each entrance to ground level.*

*During the nineteenth century, a door frame copying the east entrance was inserted to divide the central hall into two spaces.*

*Above, second floor after the completion of the circa 1850 rear addition. There was a large window or door opening in the south wall of the hyphen.*



# PAVILION V

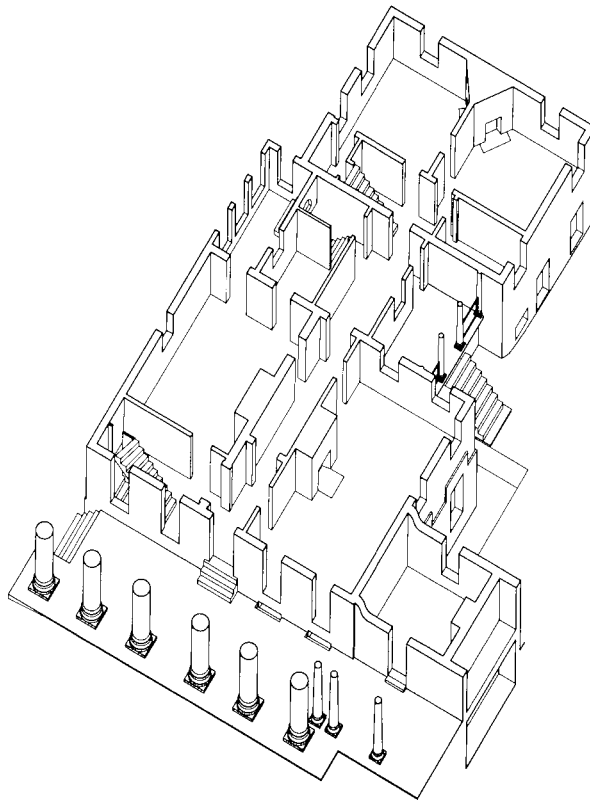
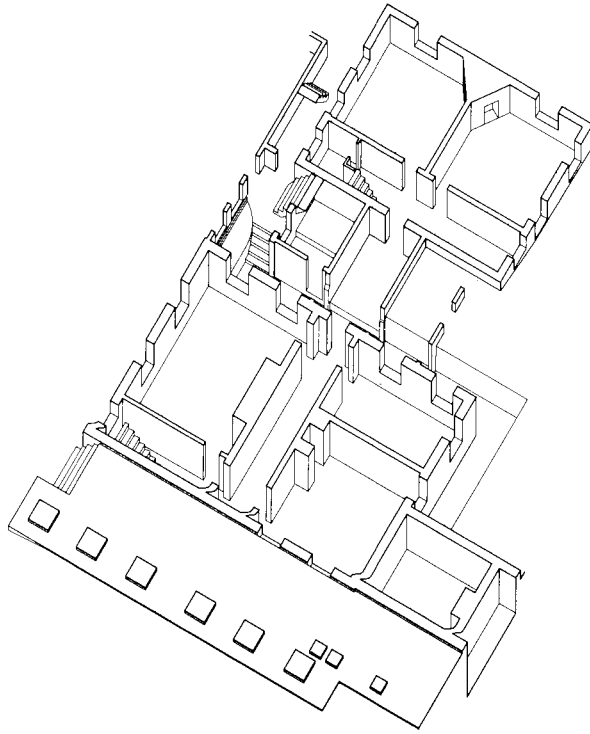

## HISTORY

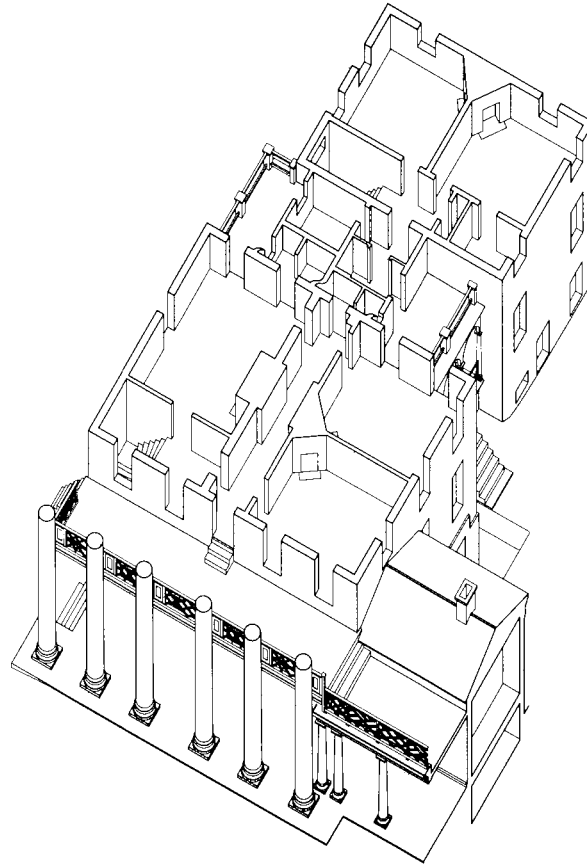

### CIRCA 1903-1929, EARLY CHANGES

*In the early twentieth century, a number of modifications took place in the hyphen and rear addition. Physical evidence and paint analysis reveal that there were at least two generations of changes. The three axonometrics on this page show the earlier changes.*

*Top left, basement. In the rear addition, the stair has been moved to the south end of the hall. A room has been added immediately south of the circa 1850 hyphen.*

*By the early twentieth century, the basement windows had been enlarged.*

*Bottom left, first floor. The pavilion was modified to form two separate residences. The addition south of the hyphen created a room (conservatory?) with three large, arched windows. A porch was added to the north facade as a formal entrance to the rear residence. A wide, arched opening was inserted between the original pavilion's central and front stair halls.*

*Above, second floor. The roof of the hyphen was raised, and rooms were added immediately south of the hyphen. The hyphen passage was divided into three rooms, of which two may have been bathrooms. A closet was built in the small room at the north end of the rear stair hall, and a decorative window was inserted in the south wall of that stair passage.*

# PAVILION V

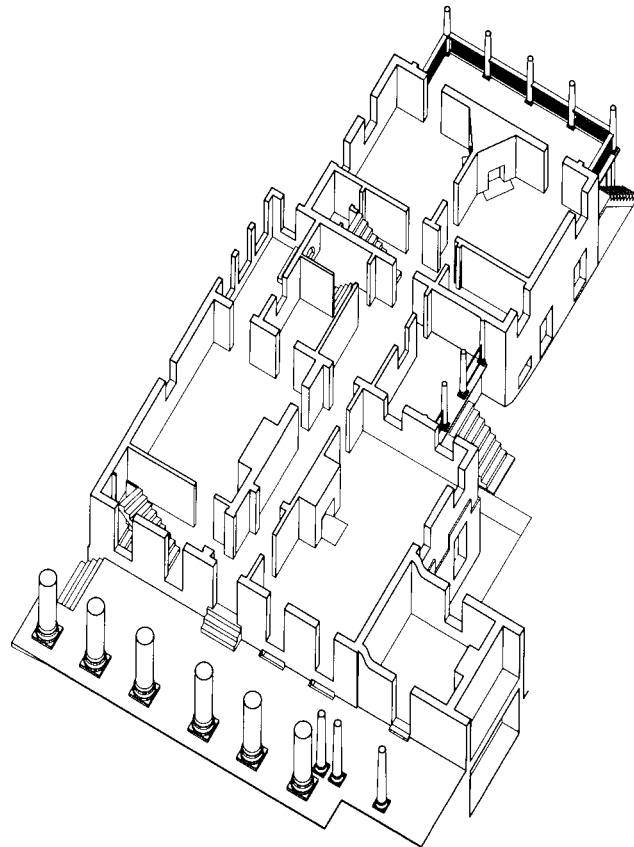
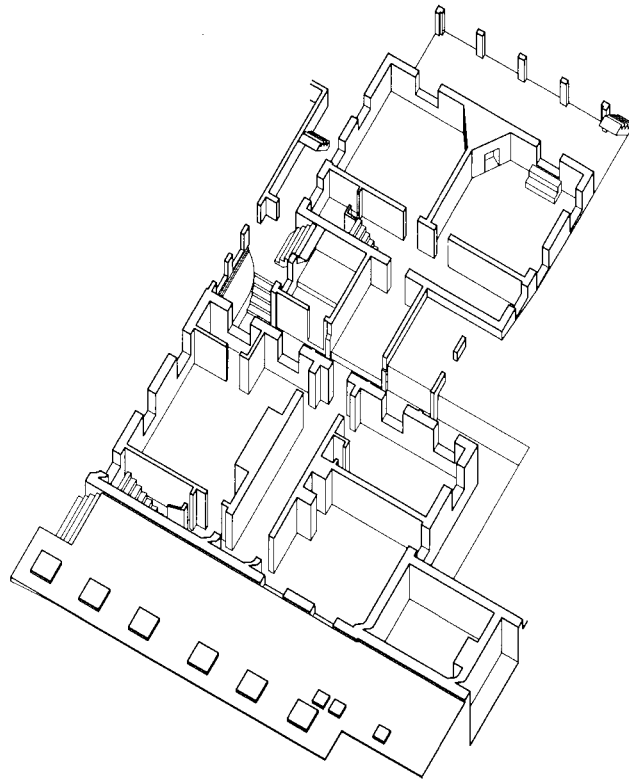

## HISTORY

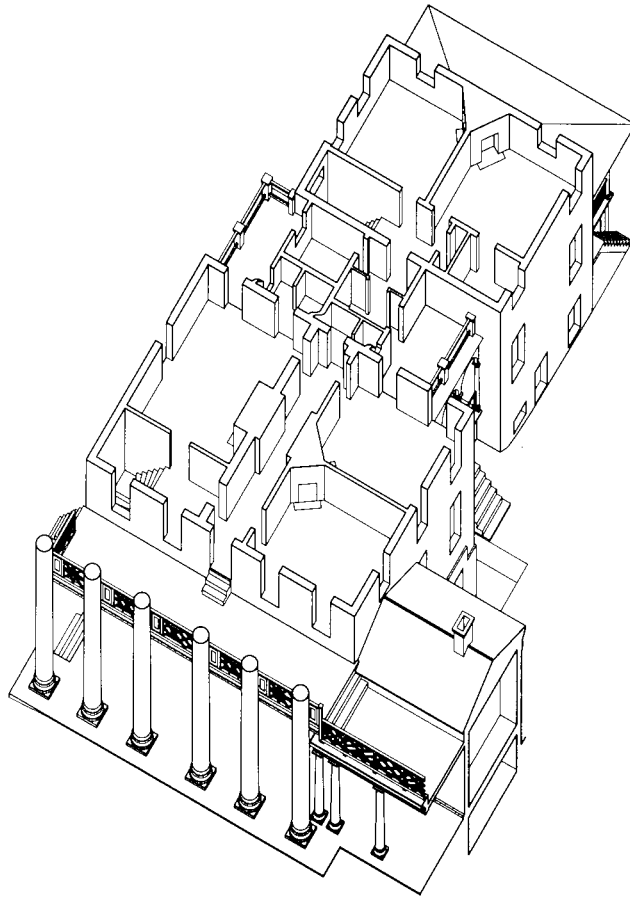

### CIRCA 1903-1929, LATER CHANGES

*The three axonometrics on this page show the later changes made in the early twentieth century.*

*Top left, basement. A bathroom was installed in the original kitchen.  
Partitions to the west of the front stair created a closet.*

*Bottom left, first floor. A porch was added to the west facade.*

*Above, second floor. The bathrooms may have been inserted or remodeled at this time.*

# PAVILION V

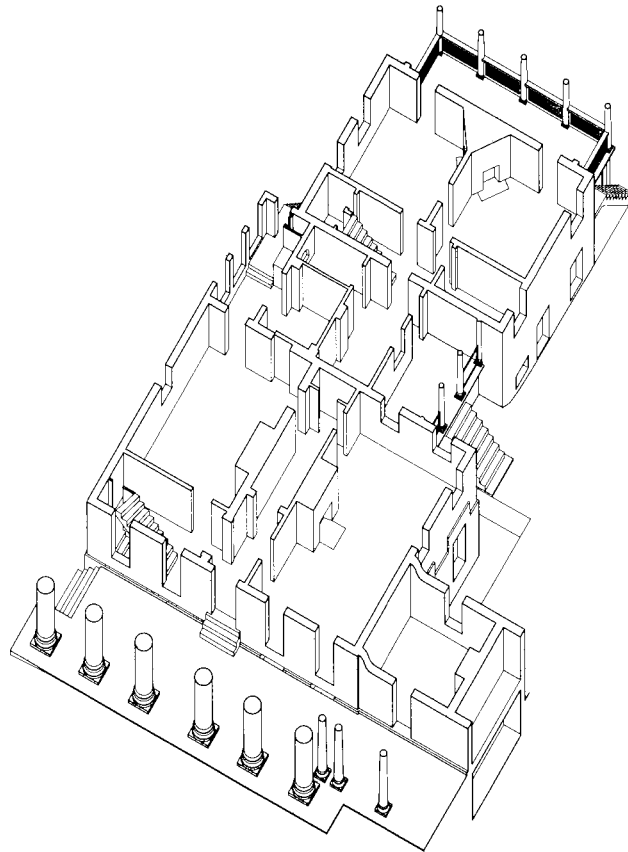
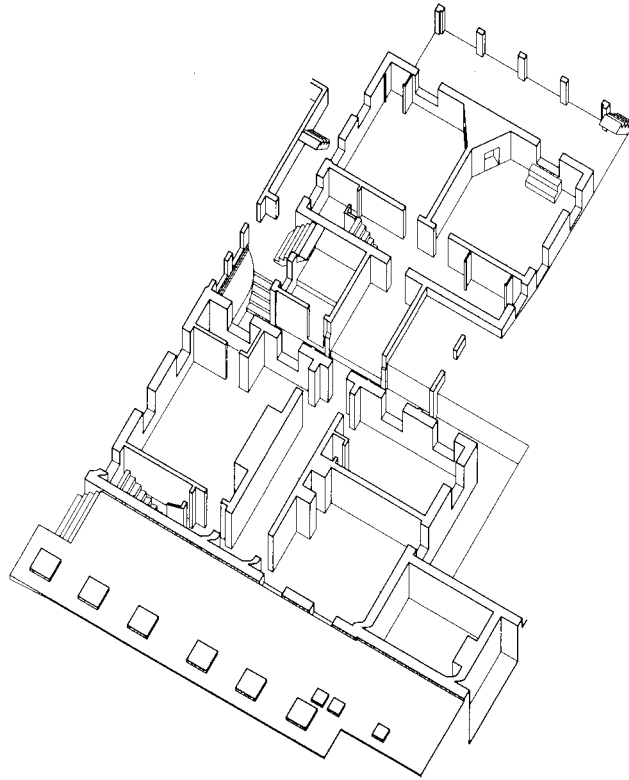

## HISTORY

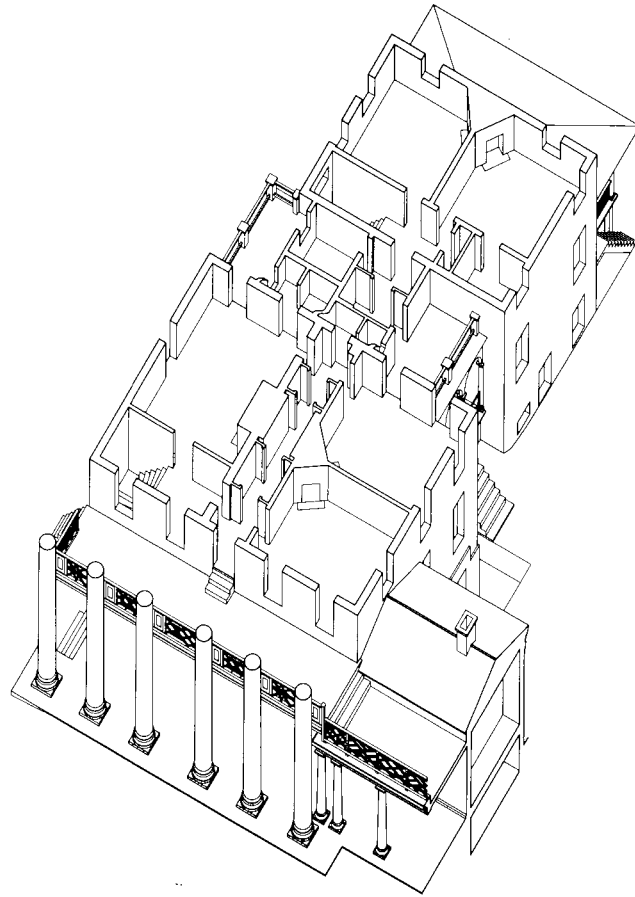

1992

*Top left, basement in 1992.*

*Bottom left, first floor in 1992. Sometime in the twentieth century a toilet room was inserted into the west end of the central hall, dividing the pavilion and rear addition into completely separate residences. The original west entrance was enclosed within the west wall.*

*Above, second floor in 1992. In the mid- or late-twentieth century, large closets were added to the central hall, and the bathrooms were renovated.*

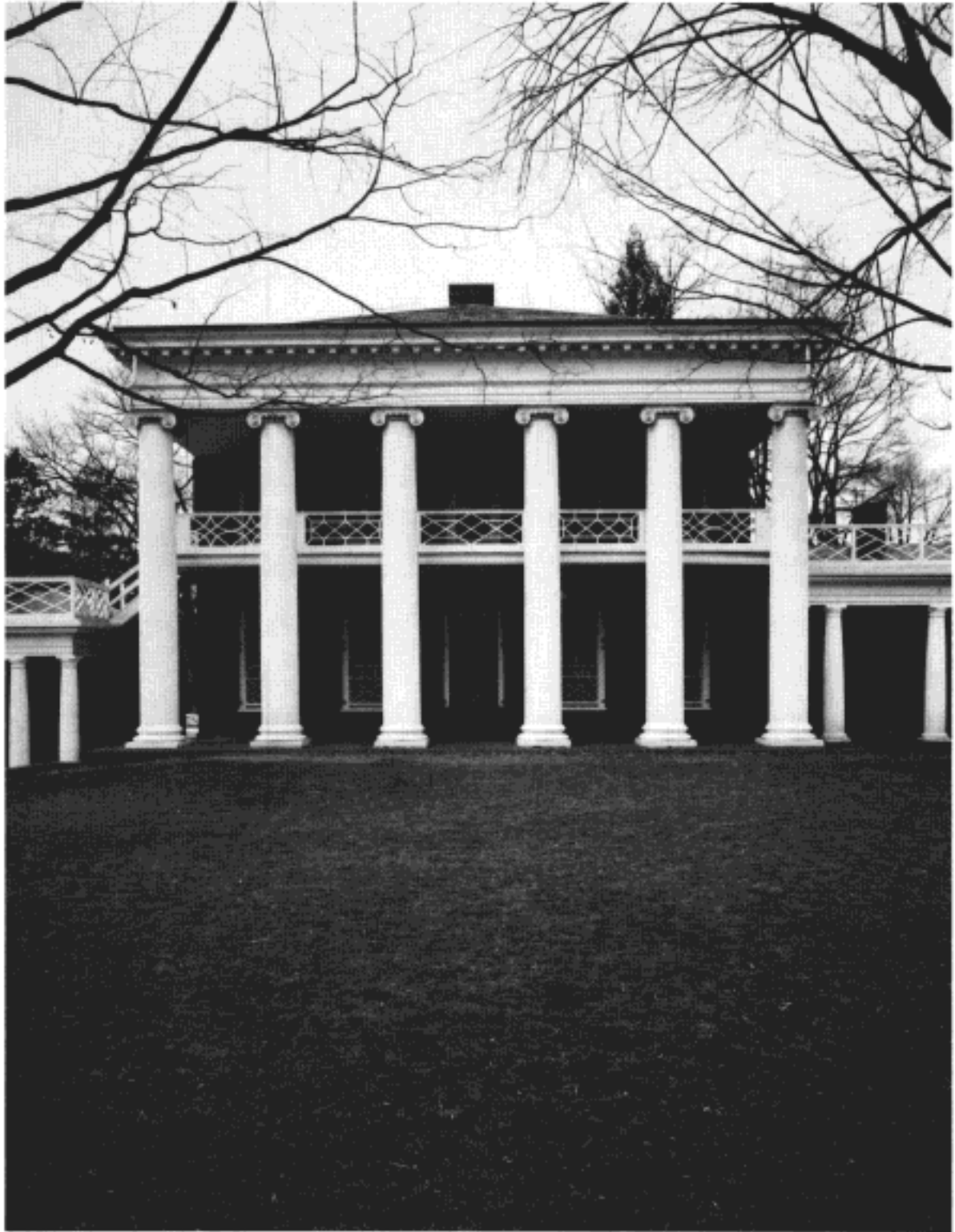

*East facade of Pavilion V*

# PAVILION V

## ARCHITECTURAL DESCRIPTION

### EXTERIOR

**P**avilion V is located near the center of the west side of the Lawn. The east facade faces the Lawn; it is five bays wide and two stories tall with a gable roof and a projecting portico. Behind the original 1819-23 pavilion is an addition built circa 1850. The addition is two stories and basement high, two bays deep, and two bays wide. A hyphen, built circa 1850 and subsequently modified between 1850 and 1903/1929, connects the two buildings; the hyphen is two stories and a basement high, three bays deep, and three bays wide. The exterior modifications and additions made to the hyphen and the rear wing are physically very evident. Differences in detailing and in paint layering indicate that this work was not carried out in a single building campaign. The work was likely undertaken in 1903, when the Pavilion was jointly occupied by Professors Smith and Kent, and in 1929 when Professors Wilson and Sparrow occupied the structure. Unfortunately, no documentary evidence was uncovered that would reveal exactly when the changes were made. In the following description, this work is identified by the dates 1903/1929.

Pavilion V and Pavilion I were similarly modified circa 1850 when large brick additions were appended to the backs of the original structures. At Pavilion I the addition was attached across the rear facade of the basement and first story, resulting in the loss of the rear windows of the original lower part of the pavilion. At Pavilion V, a massive two-story and basement addition was constructed approximately 16 feet west of the original building and joined to it by a narrow enclosed connector or hyphen. This configuration left the original rear windows of the pavilion exposed. Only much later, when the hyphen was enlarged, was the sense of separation between the original pavilion and the addition lost.



## PAVILION V

Thomas Jefferson designed the portico on the east facade using the “Ionic of Palladio” found in the 1721 Leoni edition of Palladio’s *Five Books of Architecture*. The columns have attic bases on plinths, unfluted shafts, and Ionic capitals. The bases and capitals are of stone, and the shafts are of stuccoed brick. The capitals have volutes on the front and back and balusters on the sides. The wooden entablature (4’ 5<sup>7</sup>/<sub>8</sub>” deep) has a three-fascia architrave, a plain frieze, and a denticulated cornice, which also contains an ovolo ornamented with an egg-and-dart motif.

The wood entablature moldings from the top include the cornice, which has a cymatium with a cyma recta, a fillet, and a cyma reversa; a corona supported by modillions and decorated with lead rosettes applied to the soffit between the modillions; and a bed molding consisting of an ovolo with egg-and-dart ornament and a cavetto. The substrate and the eggs of the egg-and-dart ornament are of carved wood to which delicately cast lead darts are attached. Below a plain frieze, the architrave has a fillet, a cyma reversa, and three fasciae with beads at the bottom edges.

The deep entablature of the portico is carried around the three remaining sides of the original building as a unifying element. Above the entablature there is a hipped slate roof dating to 1837. The original 1819-23 ridge-and-furrow roof remains *in situ* in the attic. The original 1819-23 chimney, located immediately west of the ridge, was extended when the existing roof was constructed and now projects approximately 3’ 0” above the peak.

### EAST FACADE

The east facade is deeply recessed behind the columns of the portico. The facade is constructed of hand-made red brick, varying slightly in size, laid in Flemish bond with king closers at the window openings and queen closers at the ends. The bricks are 7<sup>7</sup>/<sub>8</sub>” to 8” long by 3<sup>3</sup>/<sub>4</sub>” to 3<sup>7</sup>/<sub>8</sub>” wide by 2<sup>5</sup>/<sub>8</sub>” to 2<sup>3</sup>/<sub>4</sub>” high, with six courses equal to 1’ 5<sup>1</sup>/<sub>2</sub>”. The mortar in the narrow joints is recessed along the edges and is nearly even with the face of the brick at the center.

The pavement of the portico on the first story is twentieth-century brick laid in a herringbone pattern with a six-brick-wide border parallel to the facade. Three stone steps lead to the wood threshold of the doorway in the center bay. The steps are 5’ 6” wide and approximately 1’ 1<sup>3</sup>/<sub>4</sub>” deep. The lowest riser is approximately 6<sup>7</sup>/<sub>8</sub>” high, while the upper risers are 8” high; the treads are approximately 1<sup>3</sup>/<sub>4</sub>” thick. The original entrance door and the transom above are set in a 9<sup>1</sup>/<sub>2</sub>”-deep

## ARCHITECTURAL DESCRIPTION

reveal with raised panels corresponding in dimension and placement to those of the door. The paneled reveal, as well as the two-fascia architrave encompassing both the door and the transom ( $7\frac{7}{8}$ " wide with two fasciae, a cyma reversa, and a fillet, Type T-1), and the molding between them have recently been sandpainted to resemble stone. The original rectangular transom is divided into eleven lights by delicate semicircular and radiating muntins.

The door is flanked by two-panel blinds supported by original iron strap hinges and iron pintles. The strap hinges are  $1' 9\frac{1}{4}$ " long by  $1\frac{3}{8}$ " to  $1\frac{3}{4}$ " wide. J-shaped holdbacks imbedded in the masonry wall below the blinds are later replacements. The blinds have an original iron swinging bar latch. The north blind has an oval plate ( $2\frac{1}{8}$ " wide by  $4\frac{1}{2}$ " high by  $\frac{1}{8}$ " thick) with a pivot in the center that holds a bar ( $1\frac{1}{2}$ " wide and  $1' 4\frac{1}{2}$ " long) rounded at the ends. There is a keeper on each blind. Each keeper has a trefoil-shaped base fastened to the blind with three screws and a  $\frac{1}{8}$ " thick U-shaped section to hold the bar.

To the north of the entry there are two original small basement windows, partially below grade, facing small wells below the surface of the pavement. The windows are framed by  $6\frac{3}{4}$ "-wide two-fascia architraves (Type T-2) and feature later three-light, in-swinging awning sash. The northernmost window has  $\frac{7}{8}$ " square wood bars running across the opening. The window wells are protected by sloped wood frames filled with  $\frac{1}{2}$ " hardware cloth dating from the twentieth century.

The original windows on the first floor, located in openings as tall as that of the central doorway, have  $6\frac{1}{2}$ "-wide two-fascia architraves (Type T-2) at the sides and top and  $2\frac{3}{4}$ " thick sills at the bottom. They have 6/6/6 triple-hung sash. All of these elements are original. Paired blinds flank the windows; the blinds are supported by early wrought-iron strap hinges on pintles. Original wrought-iron J-shaped holdbacks are located next to each blind. Seven remain *in situ*, and nine holes are empty. The iron holdbacks at the bottom of the blinds are later additions. Wood "Chinese" railings, similar to those on the east porch, extend across each window; these fittings are recent restorations.

Like the first story, the articulation of the second story of the east facade includes a door in the center bay and two windows at either side, each with two-fascia architraves ( $6\frac{1}{2}$ "± wide) (Type T-2). There is a twentieth-century two-panel screen door with two 3" spring hinges. The sides and top of the reveal behind the screen door are paneled. Each of the two leaves of the original door behind (Type D-21) has three panels; the upper two panels are glazed, and the lower panel is raised. The doorway is located three risers above the balcony floor. Each of the wooden

## PAVILION V



*North facade of Pavilion V*

risers is approximately 7" high. The two treads are 1' 1½" deep, with a 1" nosing, and 4' 8" wide. The original windows have 6/6 double-hung sash. The original blinds on either side of the windows are held open with iron replacement holdbacks. The original holdbacks were located at the sides of the blinds in holes positioned in the mortar joint between the twenty-first and twenty-second brick courses above the balcony deck.

The porch, beginning 1' 2⅝" behind the inside face of the columns, is hung from the structure at the attic floor level by five ⅝" diameter wrought-iron rods. The porch has a deck of random-width floorboards running east-west that slopes slightly to the east for drainage and is covered by flat-seam sheet-metal roofing material. The original 2' 11⅜"-high wood rail, including a bottom rail, a top rail (4½" wide by 3¼" high), panels behind the columns, and 1¼" by 2⅝" wood members

## ARCHITECTURAL DESCRIPTION

forming triangles, diamonds, and trapezoids between, is located along the south and east edges of the porch. The ceiling of the porch is original random width, tongue-and-groove sheathing, running east-west.

There are two duplex electrical receptacles servicing the porch: one is beneath the south window and the other is set in the wall immediately north of the door.

### NORTH FACADE

From the north all three parts of the existing structure are apparent, with the original pavilion to the east, the circa 1850 addition to the west, and the hyphen connecting the two buildings. The north facade of the original 1819-23 pavilion is three bays wide with two stories and a basement. The facade is topped by an entablature surmounted by a hipped, slate shingle roof. Both the basement and the first floor have two windows (to the west of the student dormitory rooms), and the second floor has three windows. All windows in this facade contain 6/6 double-hung sash and are framed by two-fascia architraves at the sides and top; those windows in the basement are shorter (pane size 12" by 14") than those in the upper floors (pane size 12" by 18"). The architrave profiles for the basement windows are Type T-3, and the architrave profiles for the other windows are Type T-2. The windows in the upper two floors have blinds, while those in the basement do not. The basement windows have been modified and possibly enlarged; none of the sash or trim is original.

The facade is constructed of bricks laid in common bond (five courses of stretchers followed by one course of headers). The wall of the first and second stories of the pavilion is set back from the basement wall approximately 2½".

The hyphen spans the approximately 16' 0" between the pavilion and the rear addition. It is three bays wide with two stories and a basement. The facade is topped by a 1' 1" entablature surmounted by a gabled, standing-seam, sheet-metal roof. The entablature used on the hyphen and on the addition is composed of a cornice, which has a cymatium with a fillet and cyma recta; a projecting corona with a fillet and scotia; and a bed molding consisting of a fillet, an ovolo, a fillet, and a cavetto. The architrave is a single fascia with a flush bead at the bottom edge. The hyphen cornice is an original circa 1850 feature, which was moved up from its earlier position six-and-one-half brick courses lower on the wall in circa 1903/1929 when the roof was rebuilt at a higher level. The original wood nailers for the cornice are still in place in the twenty-fifth brick course above the porch deck.

## PAVILION V

Although the roof was positioned at a lower level on the hyphen, there was still a second floor level in the connector.

At the first-floor level of the hyphen there is an original (circa 1850) 6/6 window in the center bay trimmed with a 6½"-wide two-fascia architrave (Type T-4) and an original (circa 1850) door in the west bay trimmed with a similar architrave, but 7½" wide (Type T-5). Blinds flank the window. At the second-floor level of the hyphen, a pair of centrally located circa 1903/1929 glazed doors framed with a 6"-wide single-fascia architrave (Type T-6) swings out onto a roof terrace. A small, circa 1903 or later nine-light casement window, located in the east bay of the second floor, is framed with a 3½" single fascia architrave with a perimeter cyma reversa molding.

The bricks used in the hyphen are 7¾" to 8" by 2½" by 3¾", with six courses equal to 1' 5⅛". The basement wall is laid in a common bond (five courses of stretchers followed by one course of headers), and the first and second floor walls are laid in Flemish bond.

A circa 1903/1929 covered porch at the first-floor level extends across the full width of the hyphen. The porch is divided into three bays by fluted columns (approximately 10" in diameter) supporting wood arches that have been trimmed with two-fascia architraves and an incised quatrefoil in each spandrel; the arch reveals are faced with tongue-and-groove boards. A flight of 5' 6"-wide wood stairs descends from the center bay of the porch to a stone platform at ground level. The eight risers are approximately 7¾" high with 11" treads.

Delicate railings, like those used on the east porch, extend between the columns in the east and west bays and continue down along the stairs and at the edge of the retaining wall, creating the basement passage or areaway. Similar railings running between wood pedestals along the edge of the porch roof allow that space to be used as a roof terrace.

The floor of the porch is made up of 3¼"-wide floorboards running north-south; the ceiling is covered with 2½"-wide tongue-and-groove boards, running east-west. Twentieth-century electrical features include a Colonial Revival lamp centered on the porch ceiling, a doorbell on the west architrave of the door, and rigid conduit running up through the floor in the southeast corner.

At the basement level the porch is supported by three brick arches. The center and west arches terminate at ground level; the east arch spans the passage or areaway running north-south between the hyphen and the pavilion. The floor of the passage is approximately 3' 6" to 4' 0" below ground level, and the passage is 4' 9" wide. A similar arched opening is in the east bay of the hyphen basement wall.

## ARCHITECTURAL DESCRIPTION

The north facade of the circa 1850 addition is three bays wide with two stories and a basement. A standing-seam, sheet-metal, hipped roof rises above a 1' 1" entablature (similar to the trim used on the hyphen). There are windows in the east and west bays of the first and second floor levels and windows in all three bays of the basement. The first and second floor window openings are original and have their original 6/6 sash and 7"-wide two-fascia architraves (Type T-4). The basement windows were modified in the early twentieth century. The 6/6 sash and 6<sup>3</sup>/<sub>8</sub>"-wide, two-fascia trim (Type T-7) of the two west windows date to their modification. The small horizontal basement window to the east retains its original circa 1850 size, but the trim is a later replacement.

### WEST FACADE

From the landscaped gardens to the west of Pavilion V, the west facade of the original pavilion rises up behind the circa 1850 addition. All five bays of the west facade of the 1819-23 pavilion were originally exposed and consisted of a central entrance at the first floor level (similar to the east entrance) and windows in the four flanking bays. There were five windows in the second story. With the addition of the hyphen circa 1850, the center bays were enclosed. Circa 1903/1929 the hyphen was enlarged, leaving only the two north bays and the second story south bay exposed. The four windows in the north bays have typical 6/6 sash, 6<sup>1</sup>/<sub>2</sub>"-wide two-fascia architraves (Type T-2), and flanking blinds. The second story opening in the south bay matched these windows but was converted to a doorway circa 1929 to provide access to a newly created roof terrace. The glazed double doors are framed by the typical two-fascia architrave (Type T-2).

At the basement level there is a door in the center bay (possibly added with the circa 1850 construction of the hyphen and addition) and four windows. The door is framed with a two-fascia architrave (Type T-8). The windows were modified (probably enlarged) in the early twentieth century, and their 6/6 sash and two-fascia architraves (Type T-3) date to that modification.

The west face of the pavilion, like the east elevation, is constructed of hand-made bricks laid in Flemish bond on the first and second floors; the basement wall is laid in common bond (five courses of stretchers followed by one course of headers). The bricks are 7<sup>5</sup>/<sub>8</sub>" by 3<sup>5</sup>/<sub>8</sub>" to 3<sup>7</sup>/<sub>8</sub>" by 2<sup>3</sup>/<sub>8</sub>", with six courses equal to 1' 5<sup>3</sup>/<sub>8</sub>" to 1' 5<sup>3</sup>/<sub>4</sub>". The basement brickwork was modified when the windows were enlarged in the early twentieth century.

## PAVILION V



*West facade of Pavilion V*

The only section of the hyphen visible from the west is the circa 1903/1929 extension of the first floor of the hyphen to the south face of the pavilion. A two-paneled screen door and a glazed door with a six-light fanlight, located in the west face of the extension, open to a flight of exterior stairs descending west to the basement level. The wooden stairs have eleven 8"-high risers with 10" treads. Beneath the stairs a gate opens into the areaway beneath the hyphen.

The west facade of the rear building is made up of 7 $\frac{3}{4}$ " to 8" by 2 $\frac{1}{2}$ " by 3 $\frac{3}{4}$ " bricks laid in Flemish bond at the first and second floors and laid in common bond at the basement, with six courses equal to 1' 5 $\frac{1}{4}$ ". The elevation has two bays with two stories and a basement. A wood porch added in circa 1929 extends across the addition. There were originally two 6/6 windows in each of the upper floors,

## ARCHITECTURAL DESCRIPTION

placed at the north and south ends of the building, with 7½"-wide two-fascia architraves (Type T-4). With the construction of the porch the windows on the first floor were modified, and pairs of glazed doors were placed in the two openings. The doors are framed with 7¼" to 7½"-wide two-fascia architraves (Type T-4). The north door has a pair of two-panel screen doors, and the south door has a five-panel screen door.

Both basement windows were modified in the early twentieth century, and the north window was further modified when a glazed door was inserted in the opening. The 6/6 sash in the south opening and the 5½"-wide single-fascia architraves of both openings (Type T-9 to the north, and Type T-10 to the south) date to those modifications. The north basement opening has a two-panel screened door.

The circa 1929 wood porch at the first-floor level has two engaged wood columns to the east and five wood columns to the west; the columns are 8½" in diameter. The porch floor and ceiling are made up of 2½"-wide tongue-and-groove boards running east-west. Stairs that are 2' 9¼" wide lead down from a landing at the northeast corner of the porch west to the brick pavement beneath the porch. There are eleven risers measuring 7" high with 11"-deep treads (including a 1½" nosing). This stairway was constructed some time after the porch was built; the porch railing originally extended completely across the north end of the porch. The north, west, and south edges of the porch are protected by a 2' 8"-high railing consisting of long, horizontal recessed panels running between the columns capped with a 2¾"-high by 7½"-wide top rail. The recessed panels are made up of 2½"-wide vertical tongue-and-groove boards.

Electrical elements within the porch include a twentieth-century Colonial Revival lighting fixture on the ceiling, and a cast-iron wall bracket lighting fixture with a glass shade. Below the fixture is an early twentieth-century box with tumbler switch. Rigid conduit runs from the fixture into the ceiling and from the box down through the floor.

The space beneath the porch is finished with brick pavers laid east/west with a rowlock course around the perimeter. Brick piers placed beneath each of the porch columns support the structure. Rigid electrical conduit runs from the tumbler switch in the porch to a tumbler switch on the south wall of the addition and branches off to run to a porcelain light socket mounted to the framing beneath the porch.



## PAVILION V



*South facade of Pavilion V*

### SOUTH FACADE

The south facade of the original pavilion is three bays wide. There are three windows in the basement. The center and west openings are original but were modified, possibly enlarged, in the early twentieth century. They have 6/6 sash and 5"-wide single-fascia architraves (Type T-3). The east opening does not appear in the Jefferson plan and may have been added or simply modified in the early twentieth century. The east window has a 3/6 sash and a 6½"-wide two-fascia architrave (Type T-11); its perimeter molding appears to be a recent replacement.

The original windows in the first and second stories are approximately centered between the west and center basement windows. These windows are typical of the other windows in the pavilion, with 6/6 sash, Type T-2 two-fascia architraves and blinds.

## ARCHITECTURAL DESCRIPTION

The hyphen is three bays wide and spans the area between the rear addition and the pavilion. The first story of the hyphen was extended to align with the south facade of the pavilion in circa 1903/1929. At that time three impressive arched windows, each with 25/25 sash below a nine-light fanlight, were installed to provide light to the new room. The windows are set between fluted wooden pilasters supporting three-fascia architraves trimmed with wood keystones and resting on a continuous wood sill. The roof of the hyphen extension is used as a roof terrace. The roof is covered with flat-seamed, sheet-metal roofing material (2' 2½" by 6' 0" pans) painted red; the edge of the porch is enclosed by wood pedestals and 2' 7"-high railings similar to the railings used on the north roof terrace.

The facade above the porch is topped by a 1' 1" entablature, which duplicates the one on the north facade. This is the original entablature from the south wall of the circa 1850 hyphen (now enclosed in Rooms 207 and 208) relocated here when the hyphen was extended and the roof height increased circa 1903/1929. There are two circa 1903/1929 windows in the second story of the hyphen. They have 6/6 sash, 6¾"-wide two-fascia architraves (Type T-12), and blinds.

The basement of the hyphen's extension has three arched openings. The facade is trimmed with slightly recessed horizontal panels above each arch. The center and east openings are filled in with lattice work. Shallow, brick-paved steps lead through the west opening into a passage enclosed by the arched masonry wall to the south, the brick wall of Room B06 to the north, a gate to the west, and the pavilion to the east. The ceiling of the passage is finished with plaster on circular-sawn lath. The small room (B06) was added circa 1903/1929 with the extension of the hyphen. Wooden steps to the west of that room lead to the first floor of the hyphen. A window at the east end of Room B06 retains its original 6/6 sash and 5¾"-wide single-fascia architrave (Type T-10). An electrical lamp socket with twisted, cloth-wrapped wire is suspended from an old junction box at the east end of the passage ceiling.

Five broad brick steps descend from the south passage entrance to the east end of the passage, where it turns north and continues beneath the hyphen. Within this passage the east face of the hyphen basement has a vestibule in the center, Room B06 to the south, and exterior storage space beneath the porch to the north. The door to Room B06 dates to circa 1903/1929 and is framed by a plain 2"-wide frame. The floor of the vestibule steps up 1' 0" from the floor of the passage and is paved with bricks. The ceiling is formed by the exposed framing of the first floor of the circa 1850 hyphen. The wooden members are covered in multiple layers of

## PAVILION V

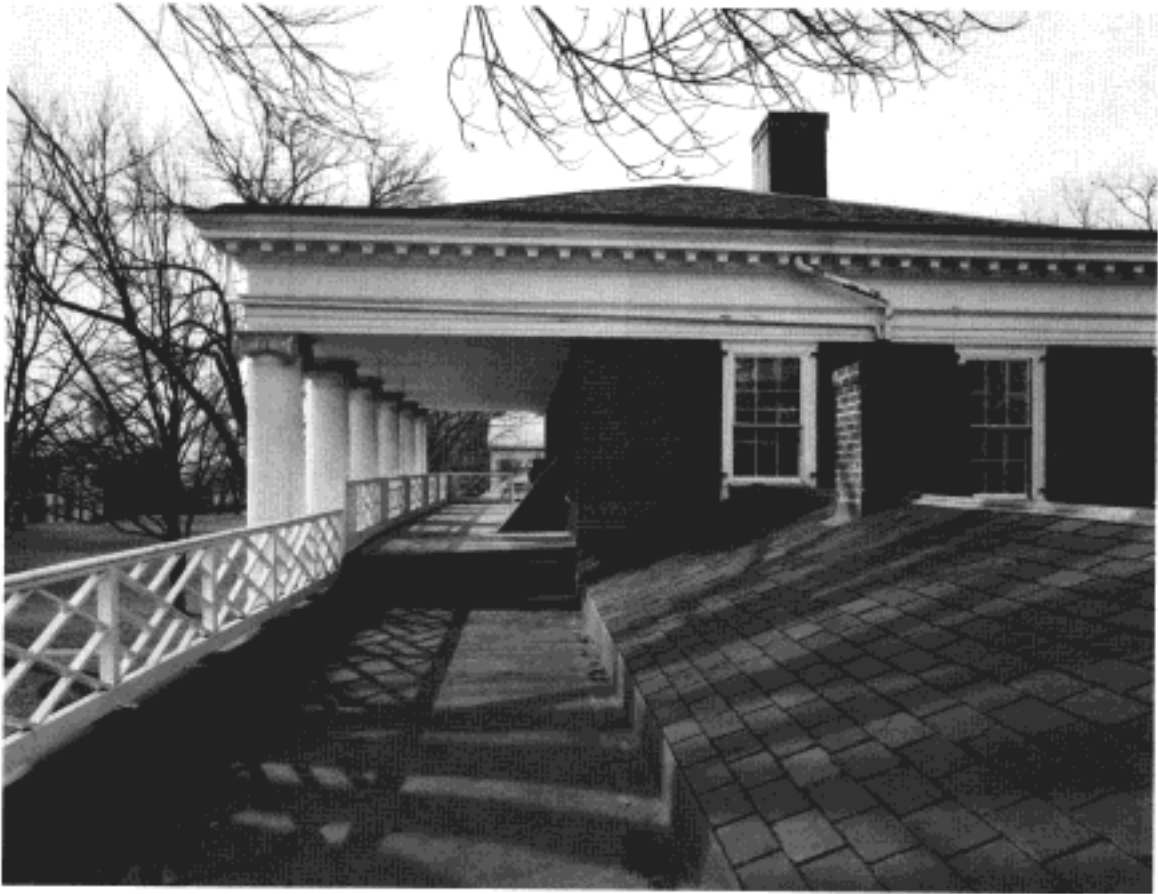

*Colonnade and east porch from the north*

whitewash. Remnants of old electrical systems, including junction boxes, electrical panels, and wiring, remain on the north wall of the vestibule. A door in the center of the west wall of the vestibule provides access to the basement of the rear addition. The twentieth century, solid-core door has been placed in a circa 1850 opening framed by simple wood framing members.

To the west of the hyphen is the south facade of the rear addition. The first and second stories each have two windows placed closely together near the center of the facade, with original 6/6 sash, two-fascia architraves (Type T-4), and blinds. A small horizontal window, immediately east of and slightly lower than the second story windows, lights the stairway of the rear addition. The window has a 25 light, pivoting, decorative sash and was inserted when the hyphen was enlarged. The two window openings in the basement retain their original six-light casement sash and 6¼"-wide two-fascia architraves.

## ARCHITECTURAL DESCRIPTION

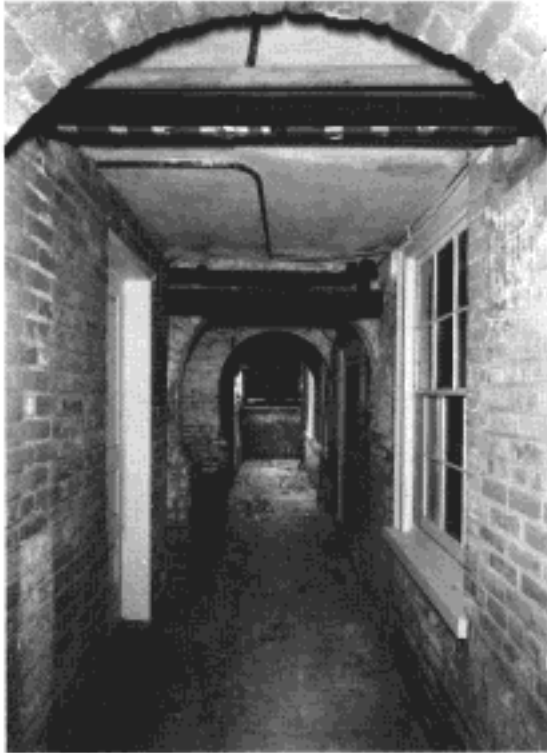

*Basement passage between original pavilion and hyphen, looking north*



*Basement passage beneath Room 106A*

Immediately south of the addition a set of wooden stairs descends to the west from the first floor of the hyphen, and a wall, flush with the south face of the hyphen, extends west and then south to enclose the pavilion garden.

### PAINT INVESTIGATION

The investigation of the exterior painted elements of Pavilion V revealed approximately 16 layers of accumulated paint on some portions of the original 1819-23 building. The east porch railing is original and was apparently painted more frequently, retaining 23 or more layers of finish. About 13 layers of paint are extant on the wooden surfaces of the circa 1850 rear addition.

Wood elements, including the cornices, window trim and sash, door trim, and the east porch, were originally primed and painted in a yellowish white (2.5Y9/1). Accumulated dirt is very evident between each succeeding application of paint. It

## PAVILION V



*Entablature and column capital at southeast corner of pavilion*



*Original wrought-iron holdback for blind*

is particularly evident in the nineteenth-century layers. When the rear addition was constructed circa 1850 the same yellowish white color was applied to the trim there and on the older part of the pavilion. In more recent twentieth-century repaintings of the entire pavilion, the color has tended to be much whiter than the earlier finishes.

The paired front entrance doors at the first and second floors were originally grained to simulate mahogany. Later finishes include layers of various dark greens.

The original window blinds retain approximately 13 layers of finishes. A light gray primer is covered in a greenish black (10GY2.5/1) followed by a later, lighter, forest green.

The exterior door in the north facade of the circa 1850 hyphen was first finished in graining that simulated mahogany. This suggests that the mahogany graining on the original east front doors survived into the 1850s.

## ARCHITECTURAL DESCRIPTION



*Entablature at southeast corner  
of rear addition*



*Ghost of original hyphen entablature appears  
on south face of pavilion*

Paint layering on the hyphen entablatures (about 13 layers) indicates that these elements date to circa 1850. The entablatures were moved upward when the hyphen was modified and enlarged circa 1903/1929.

The deck of the east porch is covered in sheet metal that was painted first with a red/brown primer followed by a gray (5Y6/1) finish.

The first-floor window balustrades on the east facade are recent restorations and are covered in about four layers of a white paint.

The front (east) facade retains evidence of an early red linseed-oil-based stain applied to the bricks; the mortar joints were painted white.

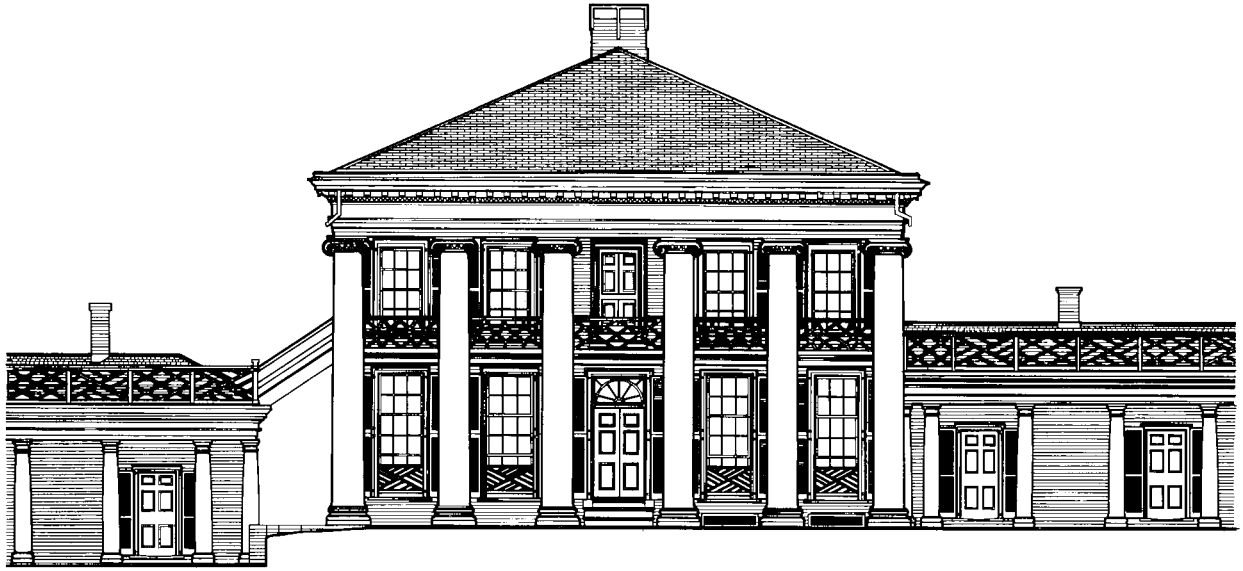

*Top, east elevation  
Bottom, north elevation*

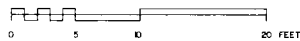
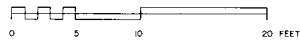
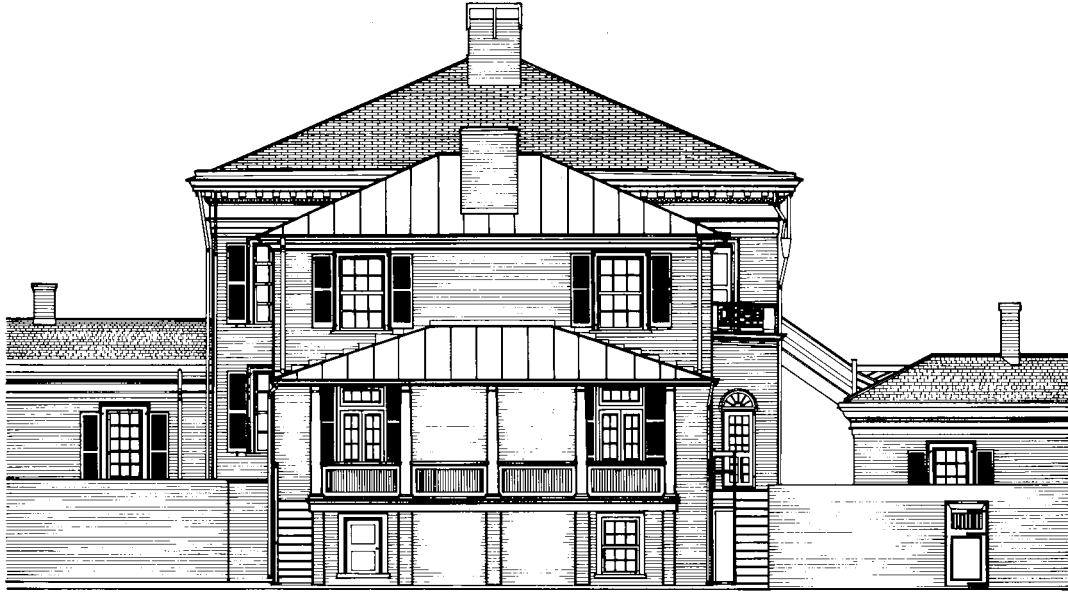

*Top, west elevation  
Bottom, south elevation*



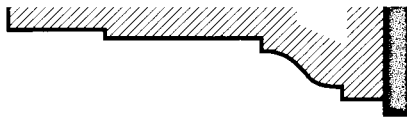

T-1



T-6

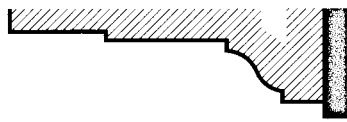

T-2

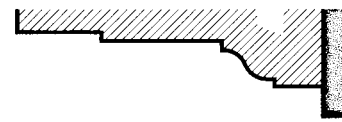

T-7

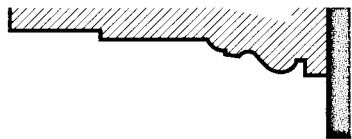

T-3

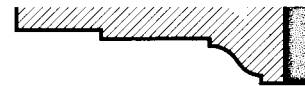

T-8



T-4



T-9

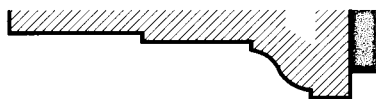

T-5



T-10



## ARCHITECTURAL DESCRIPTION

### INTERIOR

Pavilion V was examined and analyzed to document its existing condition, to determine where repairs are needed, and to provide a better understanding of the changes and modifications that the building has undergone since its initial construction. A particularly complex series of changes was revealed in the circa 1850 rear addition. These modifications and additions were likely initiated in 1903 and again in 1929 and later. No documentary evidence was discovered that would definitively date this work.

The techniques used in the examination included visual investigation and description, measuring and drawing, and comprehensive photographic documentation of the building.

As part of the physical investigation of Pavilion V, a paint analysis was undertaken to determine the original paint schemes of the interiors and to use as a tool to help in the dating of certain modifications and insertions. The paint colors were matched to those in the *Munsell Book of Color*, Matte Finish Collection, and the information from this analysis is included with the description of each room.

The hardware found on the various doors was also carefully studied to determine the nature of the original fittings and to ascertain whether any original hardware survived *in situ*. At the time of the investigation the pavilion was unoccupied. Considerable demolition and removals had occurred in the building, so it was not possible to record such fittings as light fixtures. Some surfaces were so disturbed or covered by debris that analysis was difficult or impossible.

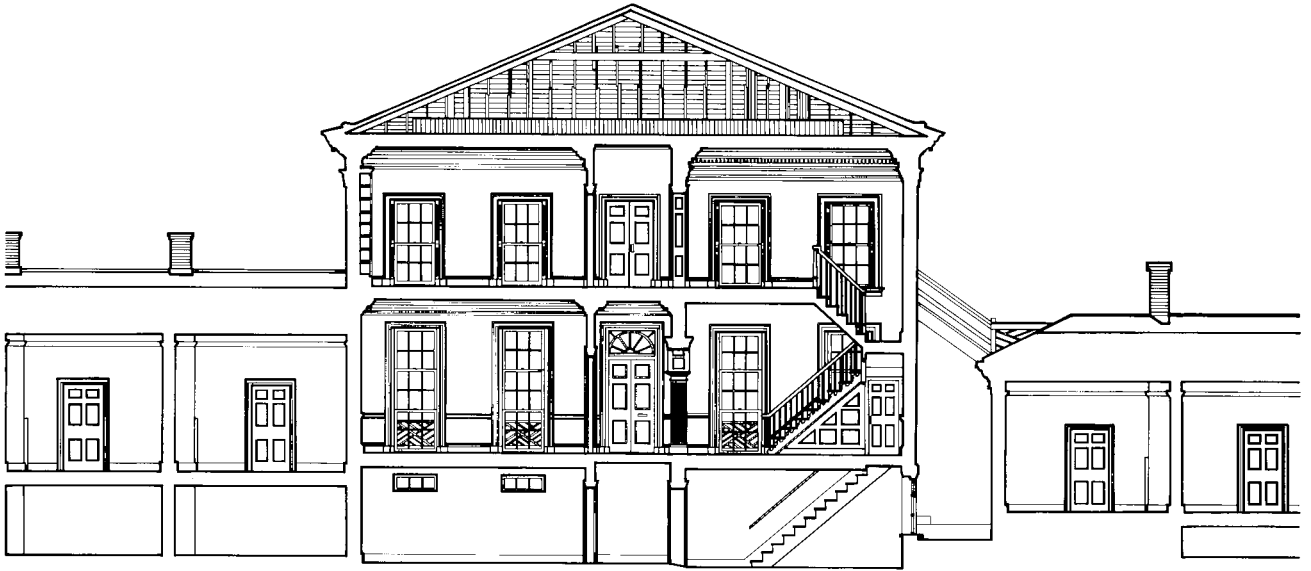

*Transverse section, looking east*



*Longitudinal section, looking south*



*Transverse section, looking west*



*Longitudinal section, looking north*

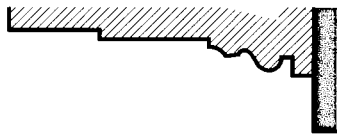

T-11

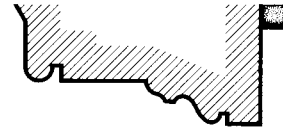

T-16

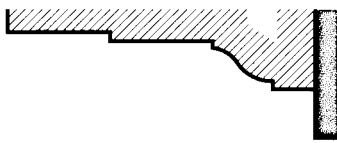

T-12

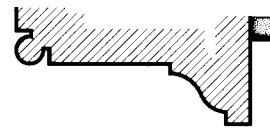

T-17

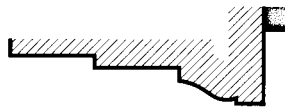

T-13



T-18



T-14

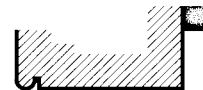

T-19

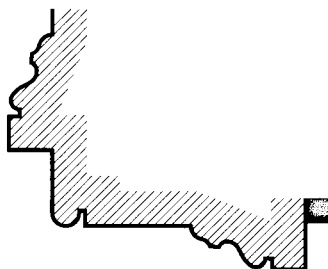

T-15

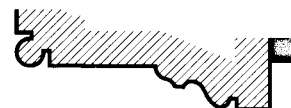

T-20

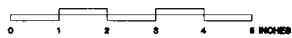

## ARCHITECTURAL DESCRIPTION

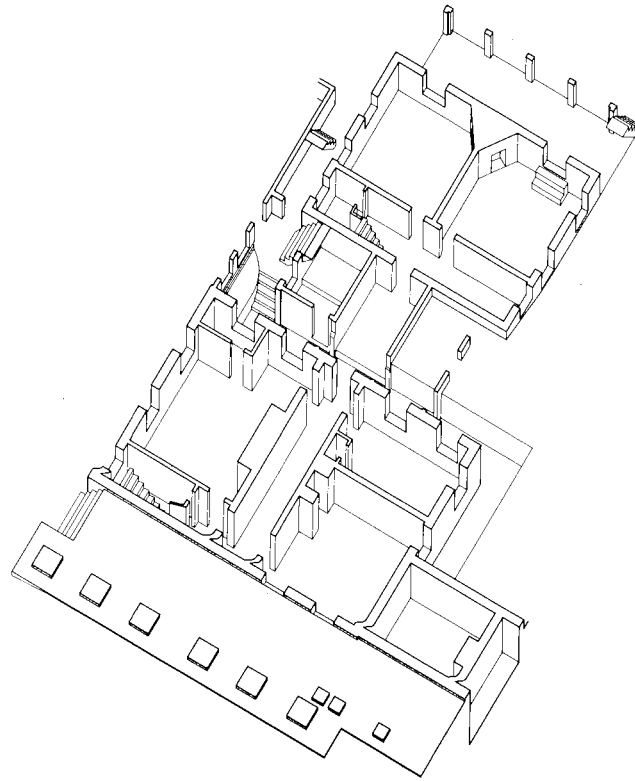

BASEMENT

The present arrangement of the basement of the original 1819-23 pavilion is nearly identical to the Jefferson floor plan. The variations between the current plan and the Jefferson drawing can be accounted for by changes made during the initial construction and by more recent modifications made in the twentieth century. The most dramatic changes involved the replacement of the original brick floors with poured concrete and the modification and enlargement of the windows. This work probably occurred circa 1903/1929.

The original kitchen function of the largest room (B05) is still evident because the much-modified cooking fireplace remains *in situ*. The original functions of the other rooms remain unknown. The basement area was considerably expanded when the rear addition was constructed circa 1850.

The three basement rooms in the addition are not immediately adjacent to the original spaces but instead are joined by an open passage located beneath the two-story connecting passage or hyphen, which joins the first and second floors.

## PAVILION V

This arrangement makes the two basements into completely separate areas.

The connecting passage and two of the spaces in the rear addition retain their original brick floor surfaces. Like those in the original pavilion, the windows in the addition have been enlarged and modified, probably at the same time that the other windows were changed.

An additional enclosed basement room (B06) was created when the connector was enlarged circa 1903/1929.

Currently, an extensive area of covered, exterior space exists under the enlarged hyphen.

After the conversion of the pavilion into two separate residences circa 1903, the basements probably became separate areas, each with a kitchen. Both of the kitchens were moved to the first floor prior to the mid-twentieth century.

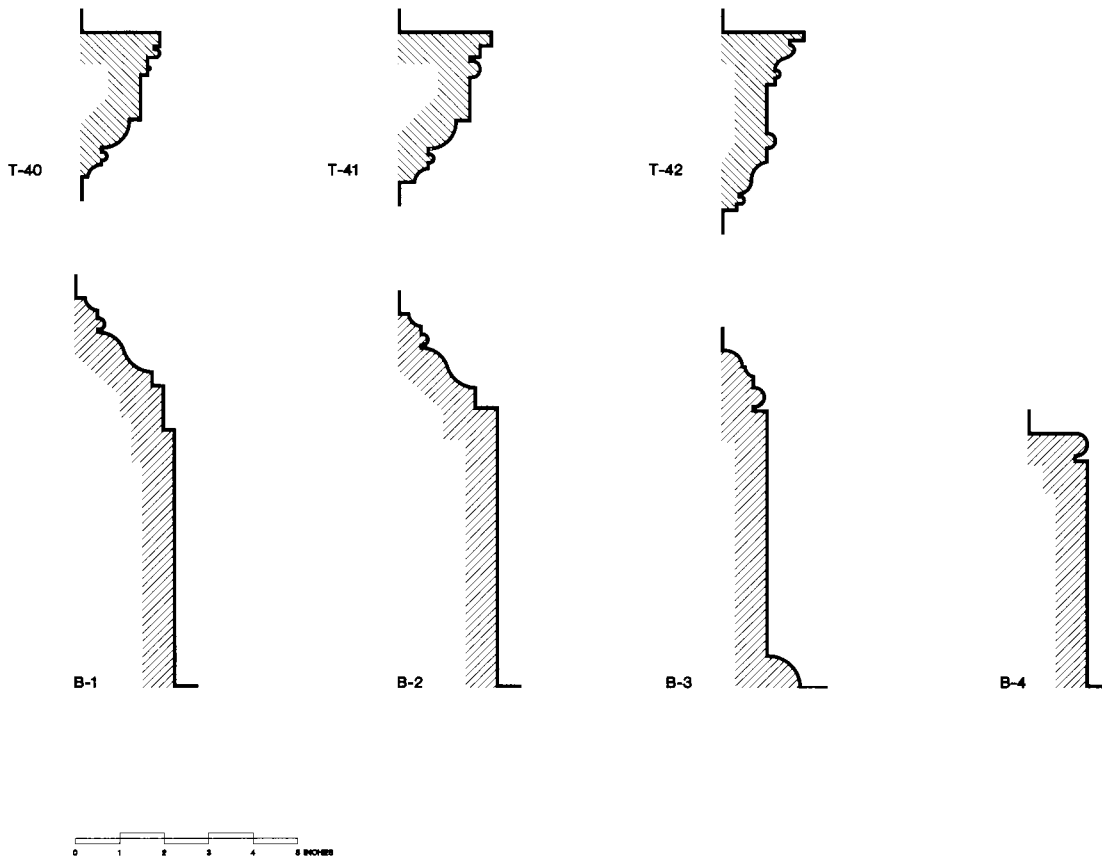

*Baseboard and chair rail profiles*

# ARCHITECTURAL DESCRIPTION

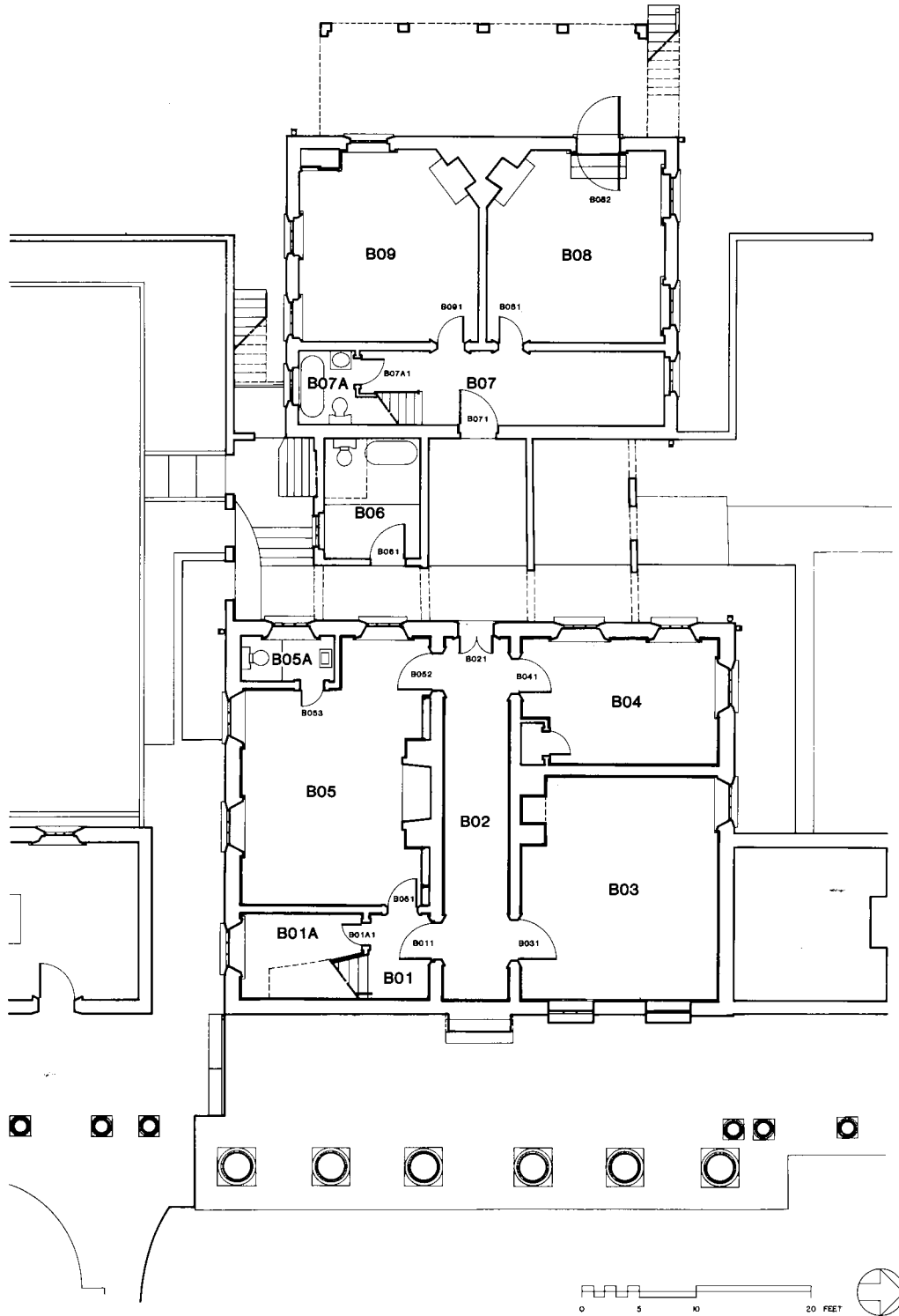

*Basement floor plan*



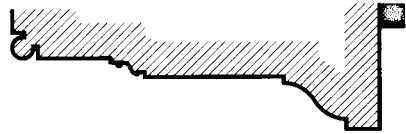

T-21



T-26



T-22

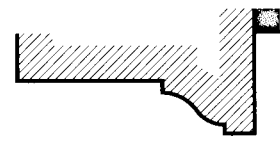

T-27

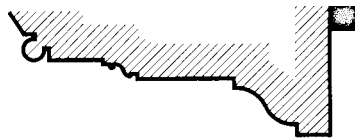

T-23

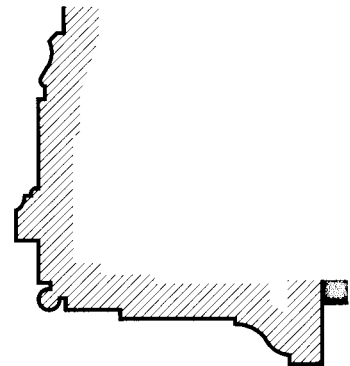

T-28

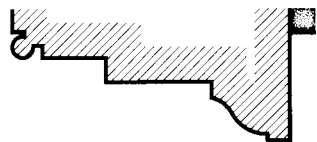

T-24

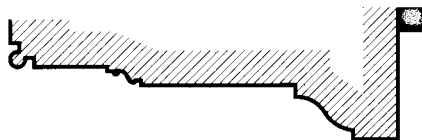

T-25

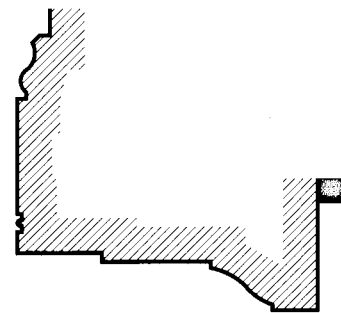

T-29



## ARCHITECTURAL DESCRIPTION

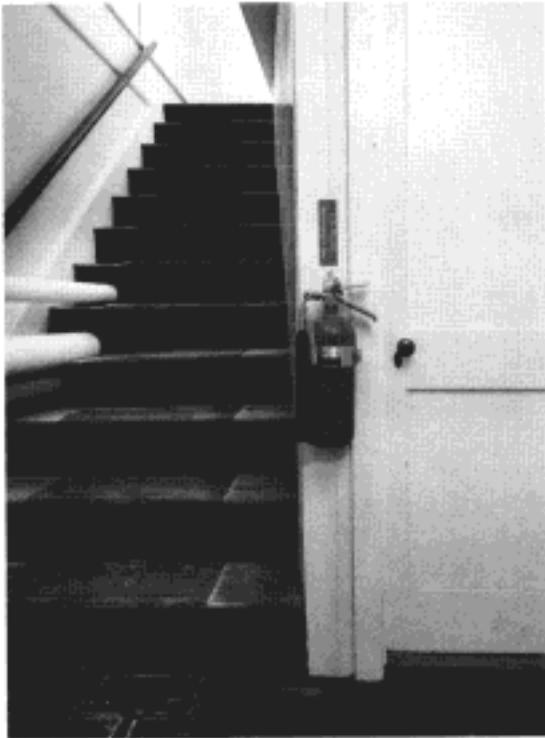

*Room B01 Front stair hall*



*Room B02 Hall*

### ROOM B01 FRONT STAIR HALL.

Some changes have been made to this small stair hall, but in plan the various elements generally follow the Jefferson scheme. On Jefferson's drawing the stair is shown as a straight run, parallel to the east foundation wall. As it exists today, the stair splays or widens as it progresses downward from the first floor. This peculiar arrangement probably became necessary when the stairway was rebuilt in the twentieth century and heating pipes were incorporated into the lower risers.

On the Jefferson plan the doorway into the kitchen (B05) is centered in the west wall. The current door is positioned further to the north; no evidence was found to indicate that Jefferson's drawing was adhered to during construction.

The hall was decreased in size in this century when a partition and doorway were inserted at the foot of the stair between the stairway and the west wall.

*Floor:* Twentieth-century concrete. Remnants of recent 9" square vinyl tiles (removed in 1992) remain on the floor. Originally, the floor surface may have been brick, as in Pavilion I. It would have been slightly lower than the current floor.

*Ceiling:* Painted plaster. At the basement level of the stair hall the ceiling is 7' 8" above the floor. Above the stair in the southeast corner the ceiling rises with the first-floor stair carriage. The original ceiling surface consisted of plaster on split-wood lath.

*Walls:* Plaster on original brick masonry, with the exception of the partition on the west side of the stairway enclosing Closet B01A, which is constructed of 5'-wide vertical tongue-and-groove boards. A 1' 0½"-high fascia board, with a bullnosed molding at the top edge and a large bead at the bottom edge, runs around the four walls of the stairwell marking the first floor level. Above this sill the paneling forming the stair wall on the first floor level is visible.

## PAVILION V

*Baseboard:* A recent, painted black band at the basement level of the stair hall imitates a 6"-high splashboard.

*Doors:* One original door opening in the north wall with a 5"-wide single-fascia architrave surround (Type T-17), one modified door opening in west wall with a 3¾"-wide single-fascia architrave surround (Type T-15), and one recent door opening in south wall with a plain, 3"-wide casing. The height of the doorway into the kitchen (Room B05) was increased in the late nineteenth or early twentieth century, perhaps in 1903.

No. B011: Original board-and-batten door constructed of 1½" thick tongue-and-groove boards fastened to three horizontal and one diagonal 1½" thick battens (Type D-1). Hardware: Pair of 4" butt hinges and a 3" by 4¼" iron box lock with brass knobs and an oval brass keyhole escutcheon. All of this hardware dates to the twentieth century. The original box lock was 5½" by 6½", and the west door jamb retains a cutout where the lock fitted against that surface.

*Windows:* The lower half of the original first-floor southeast window extends into the stair hall, and rests on the wood sill marking the first floor level. The window in the south wall of Room B01A would have served this hall prior to the construction of the south partition.

*Staircase:* The stair has a straight run of eleven treads to a landing at the south end of the hall and then turns west to the first floor level. The beaded-board partition wall enclosing the stair angles to the west so that the width of the stair ranges from 4'0" at the first tread to 2'6" at the landing. A recent pine handrail is surface-mounted to the east wall. The stairway was reconstructed in the twentieth century in its current splayed form.

*Heating:* A large steel hot water pipe, part of the Lawn's heating system, runs from B01A through the stairs and through the north wall into Hall B02. A pair of copper heating/cooling lines and a copper HVAC pneumatic control line run from B01A and through the north wall above door B011.

*Lighting:* A lighting fixture is recessed in the ceiling. EMT (electrical metal tubing) and PVC (polyvinyl chloride) electrical conduit run alongside the large heating pipe that extends north-south through the room. A pair of EMT lines run from the south wall of B01A through the north wall of B01. Switch and plastic switchplate on south wall at first floor level. Junction box for light fixture (removed in 1992) on south wall.

*Plumbing:* Galvanized-steel domestic water line from Closet B01A through north wall.

*Other Features:* Telephone cable along west and north walls near ceiling between Rooms B01A and B02.

*Paint Investigation:* The pink sandy plaster wall surface was finished in a thin coat of white plaster. A whitewash was applied first, followed by a yellowish pink (5YR7/6) and a pale pink/beige (10YR8/4).

The trim of the opening in the north wall was first finished in a beige (10YR8/4-7/4) paint covered by a dark brown glaze, producing a wood-grained surface. This original finish was overpainted in six different paints, including a red in the fourth position. The door was grained to match the trim.

### ROOM B01A CLOSET

Until the north partition was constructed, this space was part of the Stair Hall. The recent (1992) installation of insulated heating pipes next to the ceiling has destroyed that original plaster on split lath surface.

*Floor:* Twentieth-century concrete. Originally, the floor may have been brick; if brick, it would have been slightly lower than its existing level.

*Ceiling:* Painted plaster, 7'7½" above floor. Portions of the original plaster on split-wood lath ceiling survive.

*Walls:* The south, east, and west walls are plaster on original brick masonry. The recent north partition is ¾"-wide vertical tongue-and-groove boards. The west side of the stair carriage is enclosed with 5"-wide vertical, beaded tongue-and-groove boards, and the bottom surface of the stair carriage is covered with plaster.

*Doors:* Single door opening in north wall with 3"-wide plain casing. This opening is a recent creation.

No. B01A1: A recent 1¼" thick stile-and-rail door with two large, recessed panels (Type D-6). Hardware: Pair of 3½" butt hinges and a 3" by 4¼" cast-iron box lock with pair of brass knobs and a keyhole escutcheon.

*Windows:* One window opening in the south wall with plain splayed reveals and a 5"-wide single-fascia architrave (Type T-16) terminating on a ½"-thick sill and a 5"-high apron. The 3/6 wood sash have 12" by 12" panes, ¼"-wide angular muntins, and a sweep thumb latch on the meeting rails. The upper sash is fixed in place. The window is made secure by a series of horizontal iron bars fixed in the interior face

## ARCHITECTURAL DESCRIPTION



*Room B01 Front stair hall*



*Room B02 Hall*

### ROOM B01 FRONT STAIR HALL.

Some changes have been made to this small stair hall, but in plan the various elements generally follow the Jefferson scheme. On Jefferson's drawing the stair is shown as a straight run, parallel to the east foundation wall. As it exists today, the stair splays or widens as it progresses downward from the first floor. This peculiar arrangement probably became necessary when the stairway was rebuilt in the twentieth century and heating pipes were incorporated into the lower risers.

On the Jefferson plan the doorway into the kitchen (B05) is centered in the west wall. The current door is positioned further to the north; no evidence was found to indicate that Jefferson's drawing was adhered to during construction.

The hall was decreased in size in this century when a partition and doorway were inserted at the foot of the stair between the stairway and the west wall.

*Floor:* Twentieth-century concrete. Remnants of recent 9" square vinyl tiles (removed in 1992) remain on the floor. Originally, the floor surface may have been brick, as in Pavilion I. It would have been slightly lower than the current floor.

*Ceiling:* Painted plaster. At the basement level of the stair hall the ceiling is 7' 8" above the floor. Above the stair in the southeast corner the ceiling rises with the first-floor stair carriage. The original ceiling surface consisted of plaster on split-wood lath.

*Walls:* Plaster on original brick masonry, with the exception of the partition on the west side of the stairway enclosing Closet B01A, which is constructed of 5'-wide vertical tongue-and-groove boards. A 1' 0½"-high fascia board, with a bullnosed molding at the top edge and a large bead at the bottom edge, runs around the four walls of the stairwell marking the first floor level. Above this sill the paneling forming the stair wall on the first floor level is visible.

## PAVILION V

*Baseboard:* A recent, painted black band at the basement level of the stair hall imitates a 6"-high splashboard.

*Doors:* One original door opening in the north wall with a 5"-wide single-fascia architrave surround (Type T-17), one modified door opening in west wall with a 3¾"-wide single-fascia architrave surround (Type T-15), and one recent door opening in south wall with a plain, 3"-wide casing. The height of the doorway into the kitchen (Room B05) was increased in the late nineteenth or early twentieth century, perhaps in 1903.

No. B011: Original board-and-batten door constructed of 1⅛" thick tongue-and-groove boards fastened to three horizontal and one diagonal 1⅛" thick battens (Type D-1). Hardware: Pair of 4" butt hinges and a 3" by 4¼" iron box lock with brass knobs and an oval brass keyhole escutcheon. All of this hardware dates to the twentieth century. The original box lock was 5½" by 6½", and the west door jamb retains a cutout where the lock fitted against that surface.

*Windows:* The lower half of the original first-floor southeast window extends into the stair hall, and rests on the wood sill marking the first floor level. The window in the south wall of Room B01A would have served this hall prior to the construction of the south partition.

*Staircase:* The stair has a straight run of eleven treads to a landing at the south end of the hall and then turns west to the first floor level. The beaded-board partition wall enclosing the stair angles to the west so that the width of the stair ranges from 4'0" at the first tread to 2'6" at the landing. A recent pine handrail is surface-mounted to the east wall. The stairway was reconstructed in the twentieth century in its current splayed form.

*Heating:* A large steel hot water pipe, part of the Lawn's heating system, runs from B01A through the stairs and through the north wall into Hall B02. A pair of copper heating/cooling lines and a copper HVAC pneumatic control line run from B01A and through the north wall above door B011.

*Lighting:* A lighting fixture is recessed in the ceiling. EMT (electrical metal tubing) and PVC (polyvinyl chloride) electrical conduit run alongside the large heating pipe that extends north-south through the room. A pair of EMT lines run from the south wall of B01A through the north wall of B01. Switch and plastic switchplate on south wall at first floor level. Junction box for light fixture (removed in 1992) on south wall.

*Plumbing:* Galvanized-steel domestic water line from Closet B01A through north wall.

*Other Features:* Telephone cable along west and north walls near ceiling between Rooms B01A and B02.

*Paint Investigation:* The pink sandy plaster wall surface was finished in a thin coat of white plaster. A whitewash was applied first, followed by a yellowish pink (5YR7/6) and a pale pink/beige (10YR8/4).

The trim of the opening in the north wall was first finished in a beige (10YR8/4-7/4) paint covered by a dark brown glaze, producing a wood-grained surface. This original finish was overpainted in six different paints, including a red in the fourth position. The door was grained to match the trim.

### ROOM B01A CLOSET

Until the north partition was constructed, this space was part of the Stair Hall. The recent (1992) installation of insulated heating pipes next to the ceiling has destroyed that original plaster on split lath surface.

*Floor:* Twentieth-century concrete. Originally, the floor may have been brick; if brick, it would have been slightly lower than its existing level.

*Ceiling:* Painted plaster, 7'7½" above floor. Portions of the original plaster on split-wood lath ceiling survive.

*Walls:* The south, east, and west walls are plaster on original brick masonry. The recent north partition is ¾"-wide vertical tongue-and-groove boards. The west side of the stair carriage is enclosed with 5"-wide vertical, beaded tongue-and-groove boards, and the bottom surface of the stair carriage is covered with plaster.

*Doors:* Single door opening in north wall with 3"-wide plain casing. This opening is a recent creation.

No. B01A1: A recent 1¼" thick stile-and-rail door with two large, recessed panels (Type D-6). Hardware: Pair of 3½" butt hinges and a 3" by 4¼" cast-iron box lock with pair of brass knobs and a keyhole escutcheon.

*Windows:* One window opening in the south wall with plain splayed reveals and a 5"-wide single-fascia architrave (Type T-16) terminating on a 1½"-thick sill and a 5"-high apron. The 3/6 wood sash have 12" by 12" panes, ¾"-wide angular muntins, and a sweep thumb latch on the meeting rails. The upper sash is fixed in place. The window is made secure by a series of horizontal iron bars fixed in the interior face

## ARCHITECTURAL DESCRIPTION

of the opening. This window is not included in the Jefferson floor plan and may not be original. The opening may have been created or enlarged circa 1903/1929 when the other basement windows may also have been enlarged.

*Heating:* A large steel hot-water pipe with foil-backed insulation, part of the Lawn's heating system, runs along the south and east walls of the room and north through the stair carriage. A pair of copper heating/cooling pipes and an HVAC pneumatic control line run through the north and west wall; the air line branches off to run to a pressure regulator mounted to the south end of the stair wall. A pair of radiator pipes runs through the closet from Room B05 to service a radiator in Room 104.

*Lighting:* An incandescent porcelain utility fixture is surface-mounted to the ceiling. Two rigid conduits and two flexible armored cables extend from the fixture into the ceiling.

Large sheet metal electrical pull-boxes are located along the south and east walls. EMT and PVC lines run from the pull-boxes north through the stair carriage. A pair of EMT lines runs from the west end of the boxes into the ceiling and then north into Room B01. An EMT line extends into the east wall through a sheet metal panel screwed to the wall. Another EMT conduit near the floor runs from the west end of the boxes into Room B05, where it is capped.

*Plumbing:* Galvanized-steel domestic water line through south wall, up to ceiling, and out through north wall.

*Other Features:* Telephone cable along west wall near ceiling.

Built-in bookcases along the west wall are 5' 0" high and 10" deep, with five levels of fixed shelves. The bases of the units are trimmed with a 6"-high splashboard with quarter-round shoe molding, and the tops of the cases have denticulated courses and plain shelves. A 9"-deep shelf extends across west wall, supported by a pair of carved brackets and a small molding.

*Paint Investigation:* The remnants of the original plaster ceiling retain evidence that suggests that the ceiling surface was initially unpainted. The first applied finish was a pale pink/beige (10YR8/4) paint that matches the third finish used on the walls.

Twenty-two finishes were found on the ceiling.

The window trim was finished first in a cream/beige (10YR8/2-9/2), which became very soiled prior to being repainted. Three additional paint finishes were applied to the soiled surface.

### ROOM B02 HALL

This central hall connects all four of the basement rooms in the original pavilion. It is directly below the first and second floor halls and has the same configuration.

The Jefferson basement floor plan includes some details that differ from the plan as it is today. The exterior doorway at the west end of the hall does not appear on Jefferson's plan. The profile of the architrave is of a type not original to the pavilion, indicating that the doorway was a later insertion, probably added when the pavilion was enlarged circa 1850.

Jefferson's plan indicates that the entrance into Room B03 was to be through the arched recess in the north chimney foundations. The narrowness of the arched space, as constructed, and the detailing of the actual entrance to the room indicate that in this case it was not constructed according to the Jefferson plan.

*Floor:* Twentieth-century concrete. Remnants of 9" square vinyl tiles (removed in 1992) remain on the floor. The original floor was slightly lower and was probably formed of bricks.

*Ceiling:* Original plaster on lath, painted, 7' 10½" above the floor.

*Walls:* Original plaster on brick masonry.

*Baseboard:* Twentieth-century 6½"-high concrete splashboard.

*Doors:* Four original door openings with 5½"-wide, two-fascia architrave surrounds (Type T-17). A fifth opening, the exterior doorway at the west end of the hall, has a different two-fascia architrave (Type T-13); this opening was created when the rear addition was constructed circa 1850. The Jefferson plan shows the exterior rear doorway in the kitchen (Room B05) and not in this hall.

No. B021: Pair of doors with each leaf composed of 1⅞"-thick vertical beaded boards fastened to three horizontal battens on the east face (Type D-2). Hardware: Each leaf has a later pair of 4" butt hinges. The north leaf also has a later 3" by 4" cast-iron box lock with pair of hollow steel knobs and an escutcheon and a 2½"-high brass slide-bolt at the top edge of the door. The south leaf features the lock keeper and a 6" iron slide bolt at the top of the door. The doors are original to the opening but they were initially supported on 5"-high hinges. There is evidence for earlier box locks.

*Heating:* Radiator pipes running from the front stair hall (Room B01) into Room B04 extend along the east wall.

## PAVILION V

*Lighting:* Rigid metal conduit runs from electrical boxes to switches on east and west walls, duplex outlet on south wall, 30-amp safety switch on south wall servicing hot water heater, and two ceiling-mounted boxes with porcelain utility light fixtures. The conduit branches off to run up through the floor, north into Rooms B03 and B04, and south into Rooms B01 and B05.

An electrical panel is mounted to the east end of the south wall; it contains ten 20-amp breakers and a main. EMT connects this panel to a pull-box above door B011, and a pair of EMT conduits runs from the box through the north wall into Room B03. A third EMT line runs from the box west to the 1850 addition.

An old metal box embedded in east wall houses three old fabric-wrapped cables, cut off.

*Plumbing:* A galvanized-steel domestic water line enters the hall through the south wall and branches off to run north into Room B03 and west to a "Mor-Flo Industries of Johnson City, TN" 82-gallon electric hot water heater; galvanized steel pipes run from the hot water heater into Rooms B05, B01, B03, and through the west wall.

*Other Features:* Telephone cable to box on east wall and north to Room B03; station wire from box is routed to telephone jacks in pavilion. Old telephone wiring extends from box to west wall.

*Paint Investigation:* The white plaster wall surface was finished first in a whitewash that has yellowed to a beige (2.5Y8/4) color. This layer was then covered by ten or more layers of whitewash.

The original trim of the door to Room B03 was grained. This was covered with a second grained finish, followed by a deep red (7.5R3/4) paint.

The later doorway in the west wall has trim that was first painted in a deep red/brown (7.5R3/4) color. The outer molding is a later addition to the trim and does not feature the red/brown finish.

### ROOM B03 STORAGE

The original function of this large room is unknown. It may have served as a storage room, as it did most recently.

Although the Jefferson plan of this room does not include the two small windows in the east wall and indicates that the entrance was to be located in the arched recess of the chimney foundation, it is likely that the present windows and the doorway are original openings.

All of the basement windows have been modified in some manner, probably enlarged, and that is the case with the window in the north wall.

Recent work (1992) involving the installation of piping and conduits has considerably damaged the original plaster and masonry of the north and south walls.

*Floor:* Twentieth-century concrete. The current surface is slightly higher than the original surface, which was probably of brick.

*Ceiling:* Original plaster on split-wood lath, 7' 5" above floor. There are some areas where expanded-metal lath and gypsum plaster have been installed.

*Walls:* Original plaster on brick masonry, with areas of more recent plaster repair.

*Baseboard:* Twentieth-century 6½"-high concrete splashboard.

*Doors:* One original door opening in south wall with 5"-wide, two-fascia architrave surround (Type T-17).

No. B031: Original board-and-batten door composed of 1½" thick vertical beaded boards fastened to three horizontal battens (Type D-3). Hardware: Pair of 4" butt hinges and a 3¾" by 4¾" iron box lock with brass knobs. The hardware dates to the twentieth century.

*Windows:* One original window opening in the north wall with plain splayed reveals and a 5"-wide architrave surround (Type T-16) terminating on a 1½" thick sill with 5"-high apron. The window has 6/6 double rope-hung wood sash with 12" by 14" panes, ⅝" muntins, and a sweep thumb latch on the meeting rails. The west end of the window trim is buried in the west wall. Nine horizontal iron bars formerly provided security. The window opening may have been enlarged in the later nineteenth century or perhaps circa 1903/1929. The trim and sash date to that modification.

Two original window openings in east wall near ceiling, with plain wood frames. Each opening has a three-light awning sash, which swings into the room on a pair of 2¼" cast-iron butt hinges. The panes are 10" by 12", and the plain, rectangular muntins are ⅞" wide. Wood stops mounted to the sill are used to hold the window shut. Although these small openings are not shown on the Jefferson plan, they may in fact be original. The sash are twentieth-century replacements.

*Fireplace:* The brick foundation of the north chimney mass is located in the southwest corner of the room. The mass includes an arched recess. There is no evidence that this recess served as the

## ARCHITECTURAL DESCRIPTION

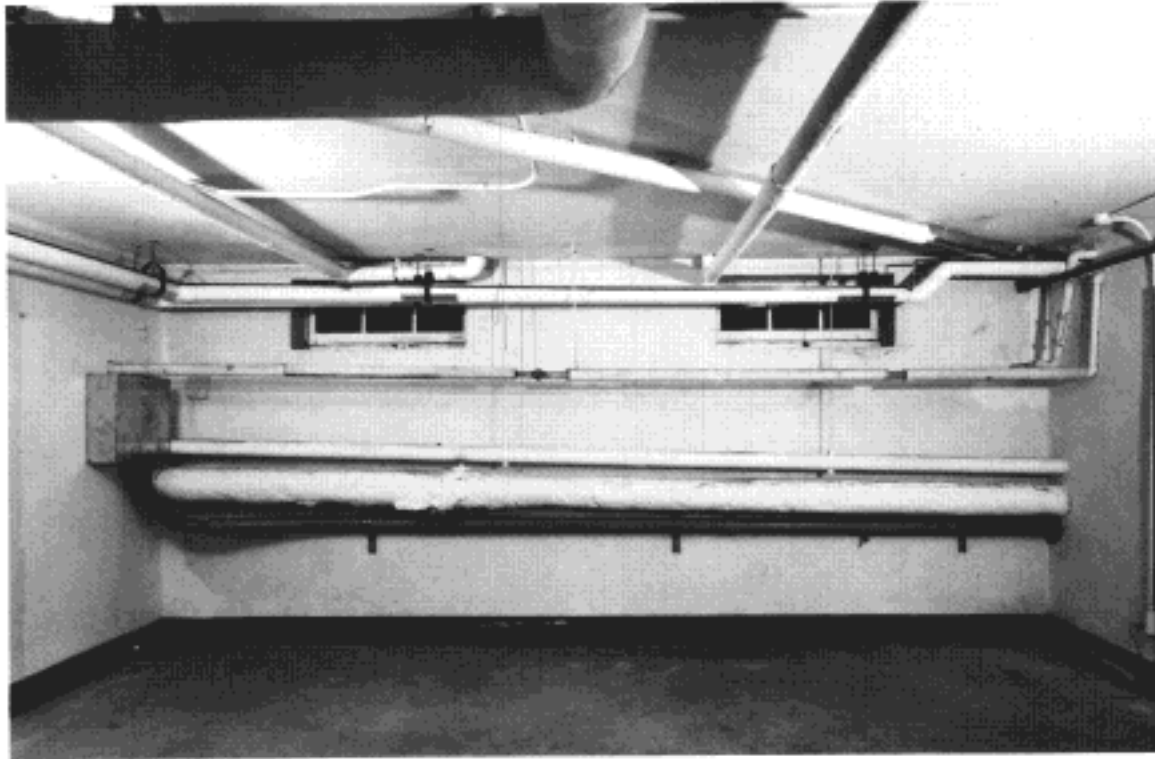

*Room B03 Storage*

entry into the room from the hall as shown in Jefferson's plan.

*Heating:* Large steel radiator pipe, hung from the ceiling, enters through the west wall and exits through the north wall, with pipes branching off to service the radiators in Rooms 102 and 203. Another large steel hot water pipe, part of the Lawn's main heating system, runs along the east wall, exiting the pavilion through the north wall. A pair of insulated heating/cooling copper lines and a copper HVAC pneumatic control air line run along the east wall and turn to exit the pavilion through the center of the north wall.

*Lighting:* Incandescent porcelain utility fixture, covered with duct tape. Rigid metal conduit runs between light fixture and duplex receptacle east of door B031 and branches off to run through north wall. Another conduit runs to a junction box on the ceiling in the northwest corner of the room. A large pull-box is located on the north wall.

*Plumbing:* A galvanized-steel water line enters the room through the east wall and extends south into

Room B02, where it exits the pavilion through the west wall.

*Paint Investigation:* The trim of the doorway, which is an original feature of the room, was first covered in a cream-colored primer followed by a medium grey (5Y6/1) finish. This surface was later covered by a grained finish with a very noticeable dirt layer. Two additional paint layers were applied over the soiled surface.

Layers found on the north window trim include an initial finish of pink/beige and a brown glaze, which formed a grained surface corresponding to the second finish on the door trim. This surface was then covered by two additional layers: a cream and a white.

### ROOM B04 WORKROOM

The ample natural light provided by the three window openings indicates that this room may have been occupied by a household servant. The three windows have been modified; they probably were



## PAVILION V



*Room B04 Workroom*

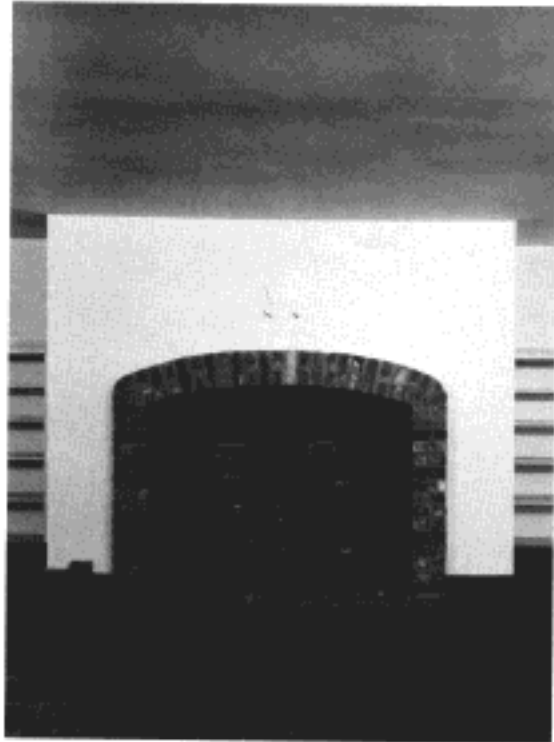

*Room B05 Den (original kitchen)*

originally like the still extant basement windows of Pavilion II, which are smaller and feature 3/6 sash. A closet was constructed in the southeast corner, perhaps circa 1929 or later.

*Floor:* Twentieth-century concrete. Remnants of 9" square vinyl tiles (removed in 1992) remain on the floor. This floor is slightly higher than the original surface, which was probably of brick.

*Ceiling:* Painted plaster, 7' 5½" above the floor. The original surface was plaster on split-wood lath, and much of that finish appears to survive.

*Walls:* Original plaster on brick masonry.

*Baseboard:* Twentieth-century 6½"-high concrete splashboard.

*Doors:* One original door opening in south wall with 5"-wide two-fascia architrave surround (Type T-17).

No. B041: Original board-and-batten door constructed of 1½" vertical tongue-and-groove boards fastened to three horizontal battens (Type D-4). 2' 0" wide by 1' 9" high recent plywood panels have been surface mounted to both faces of the door. Hardware: Pair of 4" butt hinges and a 3¾" by 4¾" iron box lock with a pair of black ceramic knobs. The lock is marked "WWII."

*Windows:* Three window openings, two in the west wall and one in the north wall, with plain splayed reveals and 5"-wide single-fascia architraves (Type T-16) terminating on 1½" thick sills and 5"-high aprons. Each window has a 6/6 double rope-hung sash with 12" by 14" panes, ¾" muntins, and sweep thumb latches on the meeting rails. The Jefferson plan does not include a window in the north wall. All of the windows have been modified, probably enlarged, and none of the sash or trim is original. This makes it impossible to determine whether the north window opening is original.

*Heating:* One-column, eighteen-section radiator hung from the ceiling with large iron bolts. A large steel pipe from Room B03 runs through the east wall and exits the pavilion through the west wall, with pipes branching off to service the ceiling-hung radiator and the radiators in Rooms 102 and 204.

*Lighting:* A fluorescent fixture is hung from the ceiling near the center of the room. Rigid metal conduit running along the ceiling enters through

## ARCHITECTURAL DESCRIPTION

the south wall and extends to the ceiling fixture and over to an electrical box at the northwest corner of the ceiling. The conduit branches off to service duplex receptacles on the east and west walls. "Wire-mold" runs from the ceiling conduit to a switch west of door B041. Bundles of wiring wrapped with tape enter the room through the south wall and run along the west wall to the northwest corner of the room.

*Other Features:* Closet B04A was removed from the southeast corner of the room in 1992. The closet was built of vertical beaded boards and measured approximately 3' 9" by 2' 5", with 4" partition walls. The detailing of this closet, the toilet room in Room B05, and the doorway partition in Room B01 indicates that all of these features were constructed at the same time, possibly circa 1929 or later.

Obsolete telephone cable runs from the south wall to the northwest corner of the room. The cable is cut at both ends.

### ROOM B05 DEN (ORIGINAL KITCHEN)

This large room originally functioned as the kitchen for the professor occupying the pavilion. Food was cooked in the large fireplace, which is still extant in a much modified form, centered on the north wall. The Jefferson floor plan clearly delineates this fireplace. Jefferson's plan shows only a single window centered in the south wall and a single window and exterior doorway in the west wall. The current conditions are much different. Because the windows were modified, probably enlarged, in the late nineteenth or early twentieth century, it has not been possible to determine if the Jefferson plan is a true representation of the 1819-23 conditions. The room may have continued to function as the kitchen until the current kitchen was installed in Room 106 on the first floor. This may have occurred circa 1929 or even later. The installation of the toilet room (B05A) in the southwest corner may have occurred circa 1929.

*Floor:* Twentieth-century concrete. Remnants of 9" square vinyl tiles (removed in 1992) remain on the floor. The floor surface is slightly higher than the original surface, which was probably brick.

*Ceiling:* Painted plaster on expanded metal lath, 7' 7½" above floor. The original surface was of plaster on split-wood lath.

*Walls:* The walls are all original plaster on original brick masonry, with the exception of the walls

enclosing the bathroom (B05A) in the southwest corner of the room, which are plaster on lath.

*Baseboard:* Twentieth-century 6½"-high plain concrete splashboard.

*Doors:* Three door openings with wood surrounds. The original north opening has a 5"-wide two-fascia architrave surround (Type T-17). The east opening has a 4¼"-wide single-fascia architrave (Type T-20). This is an original opening that was modified (increased in height) with a new door and trim in the late nineteenth or early twentieth century. The west opening into Room B05A is a twentieth-century doorway with a plain 3½"-wide casing.

No. B051: 1½"-thick stile-and-rail door with six recessed panels (Type D-7). Hardware: Pair of 3½" butt hinges and a 3¾" by 4¾" iron box lock with a pair of black ceramic knobs. The lock is marked "WWII." This door dates to the late nineteenth or early twentieth century.

No. B052: Original board-and-batten door constructed of 1⅛" thick vertical tongue-and-groove boards fastened to three horizontal battens (Type D-5). Hardware: Pair of 4" butt hinges and a 3" by 4¼" iron box lock with brass knobs. The hardware dates to the twentieth century.

No. B053: A 1¼"-thick stile-and-rail door with two large, recessed panels (Type D-6). Hardware: Pair of 3½" butt hinges and a slide bolt. This door may date to circa 1929.

*Windows:* Three window openings (two in the south wall, one in the west wall) with plain splayed reveals and 5"-wide single-fascia architrave surrounds (Type T-16) terminating on 1" thick sills. Each of the windows has 6/6 double-hung wood sash with 12" by 14" panes. The southeast window sash appear to have been replaced; there are ⅝" muntins in the lower sash, 1¼" muntins in the upper sash, and part of a sweep thumb latch is attached to the lower meeting rail. The southwest window has ⅝" muntins in the lower sash, ¼" muntins in the upper sash, and part of a sweep thumb latch on the upper meeting rail. The west window has ¼" muntins and a sweep thumb latch attached to the meeting rails. These windows were modified, probably enlarged, circa 1903/1929. The original conditions were probably similar to the extant windows in the basement of Pavilion II. In the Jefferson basement plan the north window in the west wall is shown as a doorway. If the hall doorway (B021) is a later insertion, which it does appear to be, then the rear exterior basement door may have been located here.

## PAVILION V

*Fireplace:* The original 9' 3"-wide chimney breast projects 2' 4" from the north wall and has a brick firebox and surround with a segmental arch. The opening is 5' 0" wide, 3' 8" high at the spring line, and 4' 0" high at the crown. The bricks of the firebox are 2½" high by 7¾" to 8" long, while the bricks of the firebox floor are 2½" high by 7" to 8" long by 3½" wide. The surround bricks are 2½" by 8" by 3¾". The firebox was repaired and rebuilt in the twentieth century, and the projecting brick surround is a recent creation. The floor of the firebox is now considerably higher than the original surface, which would have been at the same level as the original brick floor.

*Heating:* Four-column, 17-section cast-iron, hot-water radiator, marked "Weil-McLain Co." and "Cameo," sits between the two south windows. Insulated steel radiator pipes enter the room through the south wall and run near the ceiling along the south and west walls; the pipes exit the pavilion through the west wall. The pipes branch up through the ceiling to the radiators in Room 103 and through the east wall to the radiator in Room 104.

A pair of insulated copper pipes and a HVAC pneumatic control line enter building through south wall and run east into Room B01A.

*Lighting:* Two electrical lighting fixtures recessed in the ceiling. Electrical box with switch south of door B051; "Wiremold" conduit running from switch to electrical boxes with duplex receptacles on east and south walls. Duplex receptacle in partition enclosing Room B05A. Electrical boxes with two duplex receptacles on north partition of Room B01A and north wall of Room B05 connected with "Wiremold" conduit. Rigid metal conduit from Room B02 extends along east wall to a electrical box with 220-volt receptacle on south wall (for air conditioning unit).

*Plumbing:* Pair of domestic water lines run along west wall between Rooms B05A and B02.

*Other Features:* 5' 3"-high by 10"-deep built-in bookcases flank the chimney breast. The bookcases are trimmed with 9¼"-high beveled baseboards with quarter-round shoe moldings and a 4"-high denticulated cornice. Each bookcase has five levels of fixed bullnosed shelves. These bookcases date to the late nineteenth or early twentieth century and may have been used upstairs or in some other part of the pavilion.

*Paint Investigation:* The pink sandy plaster and white finish plaster wall surface retains at least eleven layers of painted finishes. The earliest layers

include a pink (2.5YR8/6-7/6) finish followed by a pink/beige (5YR7/4) finish.

The trim of the doorway in the north wall is composed of the original plain surround and an added outer molding. The original surface was finished in two successive applications of a pink/beige and brown glaze that formed a grained surface. This was overpainted with ten later finishes. The molding was not added until the sixth finish, another grained surface, was applied. The windows were modified at the same time; they have the same grained finish.

### ROOM B05A TOILET ROOM

The construction of this small toilet room in the southwest corner of the original kitchen occurred in this century, probably circa 1929, when other work was undertaken in the pavilion. The door type used here matches the doors of the built-in closet in Room B04 and the door in the south partition wall of the stair hall (B01).

*Floor:* Twentieth-century concrete. An 8"-high wood platform has been built into the south end of the room, to allow for plumbing lines below the toilet.

*Ceiling:* Painted plaster on expanded metal lath 7' 6" above floor.

*Walls:* The south and west walls are plaster on original brick masonry, and the twentieth-century north and east walls are plaster on lath.

*Baseboard:* A quarter-round shoe molding runs along the north edge of the wood platform. There is no other baseboard in the room; however, an 8"-high black band has been painted at the base of the walls to imitate a splashboard.

*Doors:* One opening in the east wall with plain 3½" casing.

*Windows:* An original window opening in the west wall, with plain splayed reveals and a 5"-wide single-fascia architrave (Type T-16) terminating on a 1" thick sill. The 6/6 double rope-hung sash have 12" by 14" panes, ⅝" muntins, and a sweep thumb latch on the meeting rails. This opening was modified, probably enlarged, in the late nineteenth or early twentieth century.

*Heating:* A large hot-water heating pipe runs from the south wall of Room B05, along the south and west walls of Room B05A and into the north wall of Room B05. Pipes branch off to run through the west wall and into the rear addition.

*Lighting:* Incandescent lighting fixture recessed into the ceiling. Switchplate incorporating a switch

## ARCHITECTURAL DESCRIPTION

and a electric receptacle north of door B053.

*Plumbing:* Enameled, cast-iron lavatory mounted to north wall. "Made in United States of America by American Radiator & Standard Sanitary...", and "4 5 87 Baltimore" are cast into the bottom of the basin. Chromed fittings.

Vitreous china toilet marked "11-24-42" and "Douglas Leader," against south wall.

*Other Features:* Chromed toilet paper holder removed in 1992 from east wall. Chromed soap dish on north wall.

### ROOM B06 LAUNDRY (BATHROOM)

This room was created when the circa 1850 connector was enlarged circa 1903/1929. The original function of the space is not known, but it currently serves as a bathroom. There is no access to this small room from the interior of the pavilion. The door in the east wall opens to a protected but open corridor, which extends along the back wall of the original 1819-23 pavilion and is open to the weather at each end.

*Floor:* Twentieth-century concrete. The concrete floor steps up 9½" above the exterior pavers. Within the room, a 9½"-high by 4' 6"-deep concrete platform is built against the west wall.

*Ceiling:* Painted plaster on expanded metal lath 7' 5" above floor. In the southwest corner of the room the ceiling slopes down to follow an exterior flight of stairs. The ceiling was originally formed of plaster on sawn wood lath dating to circa 1903/1929.

*Walls:* Plaster on brick masonry. The masonry forming the north and west walls dates to circa 1850. The other walls were constructed circa 1903/1929.

*Doors:* One circa 1903/1929 door opening in east wall with 2" casing.

No. B061: A 1¼"-thick stile-and-rail door with two horizontal and two vertical raised panels (Type D-8). Hardware: Pair of 2¾" butt hinges, and 4½" by 3½" cast-iron box lock with oval black pottery knobs. "Reading Hardware Co, Reading PA, USA" is cast into the lock's strike plate. A 2½" by 3¾" "Corbin" deadbolt is mounted above the lock.

*Windows:* One circa 1903/1929 window in the south wall framed with a 4"-wide architrave (including a recent stop molding) terminating on a plain 3" thick sill. The 6/6 double rope-hung sash have 12" by 14" panes, ⅝" muntins, and a recent sweep thumb latch.

*Heating:* The building's perimeter heating main

enters the room through the east wall and exits the room through the west wall. Pipes branch off to service a one-column, 18-section, ceiling hung, ornamental cast-iron hot-water radiator in the northeast corner of the room.

*Lighting:* One incandescent metal utility lighting fixture on the south wall; rigid conduit runs from the fixture through the east wall and into the exterior passage. Other electrical elements include a grounded duplex receptacle on the south wall, a 220-volt receptacle on the north wall, and a rigid conduit running from the exterior passage along the ceiling of Room B06 and up into Room 106.

*Plumbing:* One vitreous china toilet with the lid stamped "1 2812 90." One free-standing, enameled, cast-iron bathtub with ball-and-claw feet. A waste line runs from Room 106 down along the south wall and into the floor.

A pair of domestic water lines running from Room B05 enters the room through the east wall and is capped off near the west wall. A line branches off these pipes to service Room 106.

*Other Features:* Chromed soap dish and towel rack on west wall. Double-pronged hook in ceiling above bathtub. Pipe sleeve in north wall for a clothes dryer vent.

### ROOM B07 REAR STAIR HALL

This long narrow hall is part of the basement of the rear addition constructed circa 1850 for Professor Harrison. As originally completed the finishes included a brick floor, whitewashed brick walls, and exposed ceiling framing covered in whitewash. There was a single small horizontal window opening at each end, two doors in the west wall, and a single door to the exterior in the east wall. A stairway to the first floor may have ascended at the north end of the passage.

Beyond the door in the east wall is an open passage under the connector, which joins the rear addition to the original 1819-23 pavilion. That space features the same finishes but is open, through two archways, to the exterior. At the east end of that passage is a doorway into the basement of the pavilion.

Modifications made to the hall in the early twentieth century include the installation of a plaster on wood lath ceiling and the present staircase. At a later date plaster on expanded metal lath was installed on the ceiling, and a small bathroom was constructed behind the staircase.

*Floor:* Original 7½" to 8¼"-long brick pavers. Evi-

## PAVILION V



*Room B07 Rear stair hall*

dence of perimeter drain along north wall. This floor appears to be original, although the brick floor in the adjoining room (B08) is at a lower level.

**Ceiling:** Painted plaster on expanded metal lath, approximately 7' 0" above floor. Originally, circa 1850, the ceiling consisted of exposed wood framing which was whitewashed. Circa 1903/1929 a sawn wood lath and plaster ceiling was installed. Later this was replaced with the metal lath. Two later ceiling joists at the north end of the ceiling may represent the location for an earlier, possibly original, opening for a stairway from the first floor.

**Walls:** Multiple layers of paint over brick masonry. The painted finish extends above the line of the later finished plaster ceiling.

**Doors:** Two original door openings in the west wall with 2"-wide ogee surrounds (Type T-18). One original door opening in east wall. These openings date to circa 1850. Recent plain boards cover the original massive architrave of the east opening. One circa 1929 doorway in south wall, with plain 2 1/4" casing.

No. B071: A 1 3/4" thick solid core door. Hardware: Pair of 4 1/2" butt hinges, and a 2 1/4"-high "Schlage" brass mortise lock with pair of brass knobs. A 5" brass slide bolt is surface-mounted to the west face of the door. This recent door has been positioned in the circa 1850 opening.

**Windows:** One circa 1850 horizontal window opening in the north wall, recessed in wall and framed with a 2 1/4"-wide plain fascia trimmed with a bead around the opening, terminating on a plain 2 1/4" thick sill. The six-light horizontal awning sash hangs from the header on a pair of 2 1/4" steel or iron butt hinges, and fastens into the sill with an iron bolt and a more recent brass bolt on the bottom rail. The sash is old but has been modified. There are indications that the opening originally had a casement sash hinged to the west jamb.

**Stairs:** Plain, utilitarian open stringer stair with a straight run of eight treads to the first floor landing. The treads are 9 1/2" deep with a 1/2" nosing and 2' 10 1/4" wide. The risers are 10" high with a 1" nosing. A crude railing is formed of an elliptically shaped

## ARCHITECTURAL DESCRIPTION

2"-high by 2½"-wide rail, supported by a 1½" by 2" post at the bottom of the stair. This staircase was constructed in the twentieth century, perhaps circa 1903 or later. Originally there was no stairway in this location. The space above the stair functioned as a closet. The original basement stair (if one existed) may have been located at the north end of the hall, where there is evidence that later joists were inserted in the ceiling.

*Heating:* A "Perfect" three-column, fourteen-section, cast-iron hot-water radiator sits below the north window. A large steel pipe runs through the west and east walls. Pipes branch off to run to the radiators in this room and in Room 109.

*Lighting:* An incandescent, metal utility lighting fixture is surface-mounted to the ceiling near the center of the room. Rigid metal conduit runs from a fuse box in the exterior vestibule to the lighting fixture. Conduits run from the light fixture to a double switch recessed into the west wall, to a grounded duplex outlet in the west wall, to the lighting fixture in Room B09, and up into Room 108. Other conduits from the fuse boxes in the exterior vestibule extend to the hot-water heater, to grounded duplex outlets on the east wall, to the washer/dryer outlets in Room B09, to the grounded duplex outlet in Room B08, and to the electrical light fixture in Room B07A.

*Plumbing:* An "A.O. Smith Glascote Mark III" hot water heater is located in the northeast corner of the hall. The hot-water heater is marked with "Serial No. H4469 1F06993, Model No. GED-80" and "80 gallons, max. 4500 watts, 240 volt." An abandoned domestic water line enters the hall above door B071 and runs along the east wall to the northeast corner of the hall, where remnants of old plumbing lines remain in the north wall. A waste line is embedded in the north end of the east wall. A pair of domestic water lines from the hot water heater extend east, branching off to run west into Room B09 and east to exit the building. A hot-water pipe runs through stairs from B07A and out through the east wall.

*Equipment:* A telephone cable from Room B08A runs up through the stair opening to the first floor.

*Other Features:* A floor-to-ceiling cabinet at the north end of the west wall was removed in 1992. The cabinet was 1' 6" deep by 6' 3" wide.

*Paint Investigation:* The brick walls retain at least 14 layers of cream/white whitewash with clearly defined dirt layers between each finish. The trim of the doorway to Room B08 has eight layers of finish including a deep brown, oil-like surface followed by

a deep green (2.5G2.5/2) finish. The fifth finish was a bright blue.

### ROOM B07A BATHROOM

The creation of this bathroom may be contemporary with the construction of the stairway sometime in the first half of the twentieth century. This room occupies space that was originally the south end of the hallway.

*Floor:* Twentieth-century concrete. Remnants of 12" square vinyl tiles (removed in 1992) remain on the floor. This floor replaces the original brick surface, which can still be seen in the hall (Room B07).

*Ceiling:* Painted plaster on expanded metal lath 6' 7" above floor. This recent finish replaced the plaster on sawn wood lath that had covered the original whitewashed exposed framing.

*Walls:* The east, west, and south walls are original brick masonry with a skim coat of plaster and paint. The north partition and the base of the flight of stairs are covered with fiberboard.

*Doors:* One door opening in the north wall with 2½"-wide wood casing.

No. B07A1: A 1⅞" thick stile-and-rail door with two large recessed panels (Type D-6). Hardware: Pair of 3½" butt hinges, and a 5¼" brass mortise lock with pair of 7" escutcheon plates and brass knobs. A chromed towel holder is surface-mounted to the south face.

*Windows:* One original horizontal window opening in the south wall framed with a plain 2½" casing. A six-light casement sash is hung on a pair of 2½" iron or steel butt hinges from the east jamb. A small iron or steel slide bolt fastens into the sill. A metal pull is surface-mounted to the west stile.

*Heating:* The building's perimeter heating main enters the room through the stairs, turning to exit through the west wall into Room B09.

*Lighting:* One incandescent porcelain utility fixture. Rigid conduit runs from the ceiling-mounted fixture into Room B07.

*Plumbing:* The plumbing fixtures removed from this room in 1992 include: one "Trent" vitreous china toilet on the east wall, marked "6. 6. 69, 1400 CASE;" and one "Standard" enameled, cast-iron lavatory mounted to the west wall with a cast-iron bracket marked "Standard, 10½ B". An enameled, cast-iron bathtub on decorative cast-iron ball feet was positioned against the south wall. The lavatory and tub date to the early twentieth century and may have originally been placed here or moved here

## PAVILION V

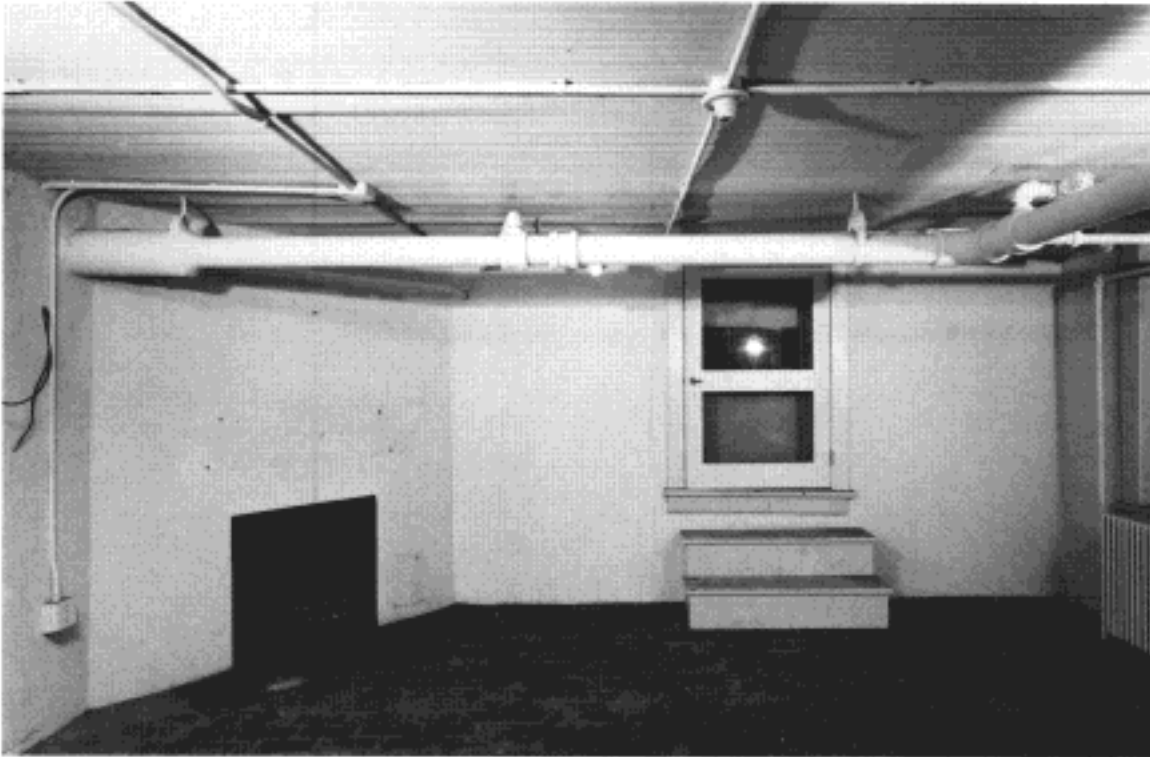

*Room B08 Storage*

from upstairs when the second floor bathrooms were remodeled.

A waste line enters the room through the east wall, extending to the lavatory on the west wall, and down into the floor.

*Other Features:* Bathroom accessories removed in 1992 include shelves and a chromed towel rack on the west wall and a chromed shower curtain rod suspended from the ceiling.

### ROOM B08 STORAGE

The function of this room at the time of its completion, circa 1850, is unknown. At that time the room included three windows (smaller than the current openings), a brick floor, and a fireplace in the southwest corner. The ceiling consisted of the exposed framing of the first floor. The room may have been converted into a kitchen when the pavilion was jointly occupied by Professors Smith and Kent in 1903. Part of the circa 1903 renovations may have included the installation of a plaster on sawn wood

lath ceiling here. Later, when the windows were modified, the beaded board ceiling was placed over the plaster surface. It is possible that the plaster ceiling is an earlier addition and that the beaded boards date to circa 1903.

Later in the twentieth century the kitchen was moved upstairs to Room 108.

*Floor:* Original brick floor approximately 7 $\frac{1}{4}$ " to 8 $\frac{1}{4}$ " by 3 $\frac{1}{2}$ " to 3 $\frac{3}{4}$ " pavers laid in a running bond in a north/south direction with one soldier course along the south wall.

*Ceiling:* Narrow beaded boards, running north/south, approximately 7' 0" above the floor. Sheet-metal patches have been made along north and east walls around plumbing and electrical lines. The ceiling finish covers an earlier, possibly circa 1903, ceiling of plaster on sawn wood lath. There is no evidence of whitewash on the ceiling framing.

*Walls:* Plaster on original brick masonry. The walls were probably originally of bare or white-washed brick, which was later covered in plaster (circa 1903) and painted.

## ARCHITECTURAL DESCRIPTION

*Doors:* One original door opening in the east wall with a 3½" single-fascia architrave surround (Type T-19). Its massive wood threshold was removed in 1992. A door has been inserted in a window opening in the west wall; the opening has a plain 5½"-wide casing.

No. B081: An original 1⅛" thick stile-and-rail door with four recessed panels (Type D-9). Hardware: Original pair of 3" iron butt hinges and a nineteenth-century wrought-iron thumb latch. An early iron hasp fits over a staple in the north jamb. There is evidence on the lock rail for an original 5½" by 8" box lock.

No. B082: A twentieth-century 1⅛" thick stile-and-rail door with a glazed panel above a recessed panel (Type D-10). Hardware: Pair of 3" butt hinges, a 2¼" brass "Schlage" mortise lock with brass knobs and a wood escutcheon plate, and a "Kwikset" brass deadbolt.

There is a 1⅛" thick stile-and-rail door with two screened panels on the exterior face of the opening. Hardware: Pair of 3" brass hinges and a brass mortised latch.

*Windows:* Two window openings in the north wall. Each window is framed with a plain 5½"-wide fascia casing on the sides. The northeast window has a ½" header, while the northwest window has no header. The architrave of the northeast window terminates on a 1½" thick sill and 4"-high apron with a flush bead at the bottom edge, and the architrave of the northwest window terminates on a ¾"-thick sill and 4"-high apron with a flush bead at the bottom edge. The 6/6 sash have 10" by 12" panes, ⅙" muntins, and a sweep thumb latch on the meeting rails. All three original window openings (including the opening converted into a doorway in the west wall) were modified and enlarged in the early twentieth century. The trim, which is contemporary with the beaded board ceiling, was installed when the windows were enlarged.

*Fireplace:* The original brick chimney breast extends diagonally across the southwest corner of the room and is approximately 6' 1" wide. There is evidence of a 1' 0"-high, 5' 0"-wide mantle shelf above the 2' 3½"-wide by 2' 7"-high opening. A 4' 5"-wide brick hearth, with 7½" to 8"-long by 3½"-wide bricks projects 1' 3½" from the chimney breast. The firebox was rebuilt and modified, and the hearth was reworked in the twentieth century.

*Heating:* One six-column, 19-section, cast-iron, hot-water radiator sits below the northwest window. The radiator is marked "National [Art?] Radiator."

A large steel pipe runs from Room B09 turning east into Room B07. One pipe branches off to service the radiator, and a pair of pipes branches off to run into the west wall; another branch line services the radiator in Room 109. Piping is routed along the base of the north wall, interconnecting the radiators in Room B08 and Room B07.

*Lighting:* A porcelain utility fixture is mounted to a junction box near the center of the ceiling. Rigid metal conduit runs from the lighting fixture to duplex receptacles on the east and north walls, to Room 110, to Room B09, and to a second porcelain utility fixture near the west wall and up to Room 110. Other conduits run from a junction box on the ceiling near the south wall to a grounded duplex outlet on the south wall, to Room B09, and up into Room 110.

*Plumbing:* None.

*Equipment:* A telephone jack is surface-mounted to the architrave of the northeast window; station wire runs out through the architrave of door B081 into the hall (Room B07).

*Other Features:* A floor-to-ceiling built-in cabinet was removed from the south wall in 1992. The cabinet was 5' 6" wide.

*Paint Investigation:* The pink sandy plaster ceiling surface, now covered by the beaded boards, was originally painted in a bright yellow/gold color to which a red/brown finish was applied. The latter layer is very soiled and deteriorated.

The original door trim and door were initially finished in a deep brown oil-like finish followed by a deep green (2.5G2.5/2) finish. The earliest finish layer on the window trim is the same deep green.

### ROOM B09 STORAGE

Unlike the ceilings in the adjoining room (B08) and hall (B07), which originally had no plastered finish, the ceiling in this room has always had a rough plastered surface. The plastered ceiling indicates that this room had some special function; perhaps the space was occupied by a servant.

The room retains two of the small window openings that were originally duplicated at the other openings of the rear addition.

*Floor:* Twentieth-century concrete. The finished surface of the concrete is about 1" higher than the original brick floor in the hall. The concrete was probably used to cover or replace an earlier brick floor paving.

*Ceiling:* Original brown coat of plaster over split-



## PAVILION V

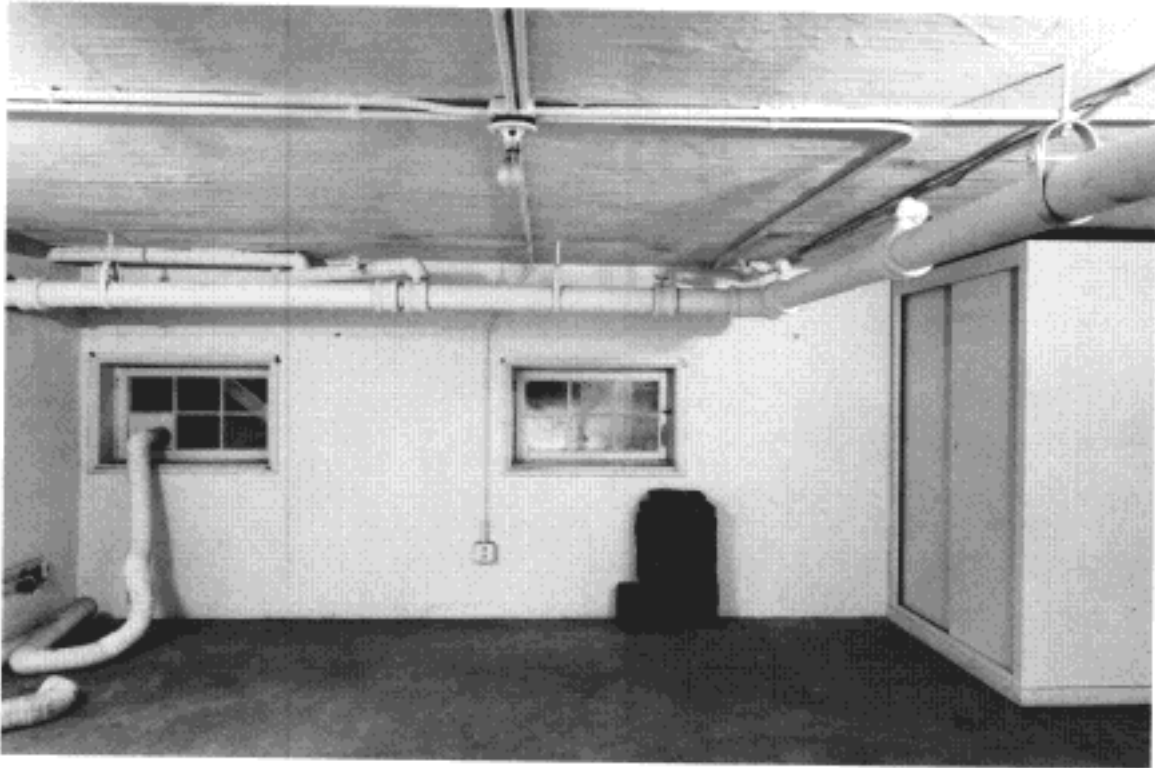

*Room B09 Storage*

wood lath 6' 5" above the floor. The surface is covered in layers of whitewash and paint.

*Walls:* Plaster and paint on original brick masonry. There are areas of repaired plaster.

*Doors:* One original door opening in the east wall with a 3½"-wide single-fascia architrave surround (Type T-19).

No. B091: Original 1¼" thick stile-and-rail door with four recessed panels (Type D-9). Hardware: Pair of later 3" butt hinges, a brass "Kwikset" dead-bolt, and a metal pull. A wire hook-and-eye and a plastic laundry accessory rack are mounted to the west face. There is evidence on the lock rail for earlier box locks.

*Windows:* Two original windows in the south wall are framed on all four sides with original 1¾"-wide molded architraves composed of an ogee and fillet molding (Type T-14). Each window has a six-light casement sash with 10" by 8" panes and ⅝" muntins; each sash is hung from the east jamb on a

pair of 2" iron or steel butt hinges. The sash are fastened with small iron bolts. The southwest window has a small metal pull. A metal sleeve, used to vent a clothes dryer, has been inserted into a pane of the southeast sash. These windows represent the original condition of the windows circa 1850; the casement sash may be replacements but the openings originally held similar casements.

One modified window in the west wall is framed with a plain 5½" architrave terminating on a plain sill and an apron with a flush bead at the bottom edge. The 6/6 sash (no ropes or chains) have 10" by 12" panes, ⅝" muntins, and a sweep thumb latch attached to the meeting rails. This window was enlarged in the early twentieth century. The simple trim is contemporary with the window trim in Room B08.

*Fireplace:* The original brick chimney breast extends diagonally across the northwest corner of the room. It is approximately 6' 3" wide. There is no

## ARCHITECTURAL DESCRIPTION

mantlepiece above the 2' 0"-high by 2' 6"-wide fire-box opening. A 4' 2"-wide brick hearth projects 1' 7" from the chimney breast. The fireplace was probably reconstructed in the twentieth century.

*Heating:* The building's perimeter heating main runs through east wall, along south wall, turning to run north into Room B08. Pipes branch off to service the radiator in Room 110 and exit the room through the south and east walls.

*Lighting:* Porcelain utility fixture mounted to junction box near center of ceiling. Seven rigid conduits extend from this fixture: one runs to a grounded duplex outlet on the south wall; two run east to Room B07 and up to Room 110; two run west and up to Room 110; and two run north, one into B08 and another up to Room 110. Other electrical components include grounded duplex outlets on the north and west walls; a 220-volt receptacle and a grounded duplex receptacle on the east wall are

both serviced by rigid conduit from Room B07 (for washer/dryer).

*Plumbing:* Water lines suspended from the ceiling run from Room B07 to the chimney breast, where they are capped off. Two lines branch off to run along the east wall to the southeast corner (for washer) and into B07A. There are small copper water lines and a waste line in the east wall.

*Other Features:* One 6' 2½"-tall plywood closet in the southwest corner of the room. The closet is 2' 2½" deep by 3' 11" wide.

*Paint Investigation:* The pink sandy plaster wall surface is covered with approximately 11 layers of a whitewash and a more recent bright yellow paint, which is covered by the current cream-colored paint. The trim of the doorway in the east wall was first covered with a brown, oil-like finish followed by the same deep green (2.5G2.5/2) finish used in Rooms B07 and B08.



T-30

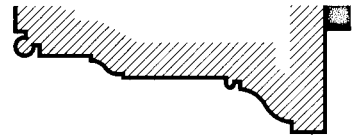

T-35



T-31

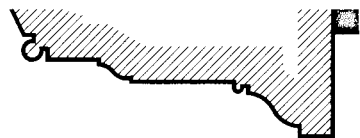

T-36



T-32

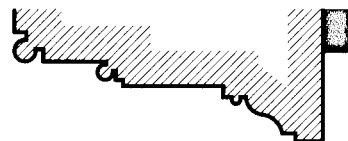

T-37



T-33

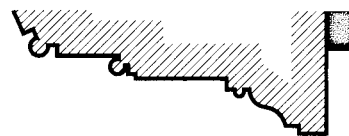

T-38



T-34

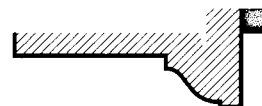

T-39

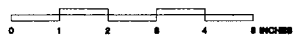

## ARCHITECTURAL DESCRIPTION

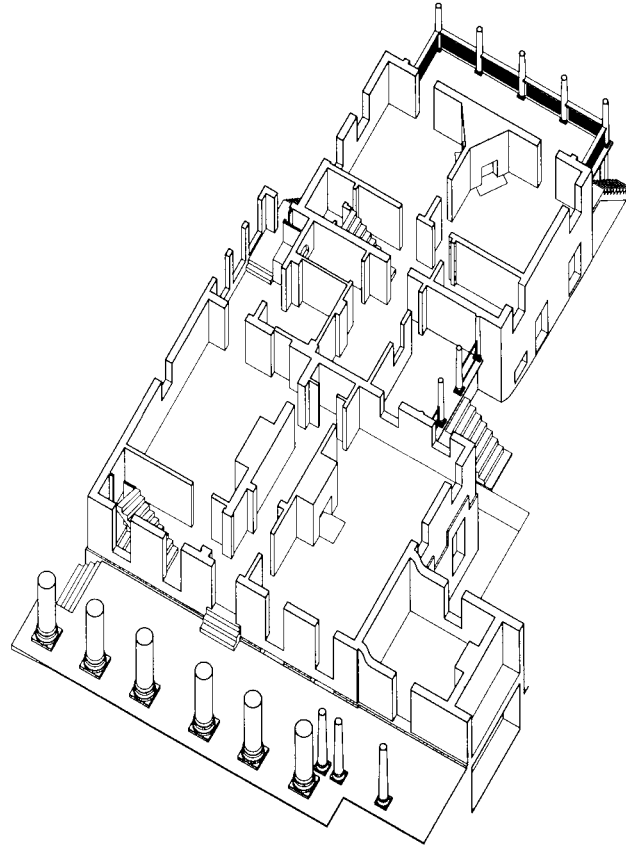

FIRST FLOOR

The first floor plan of this pavilion duplicates that of Pavilion I in both layout and overall size. It is only in the details that the various rooms differ.

As originally planned and used, the first floor had a long, narrow central hall that extended from the front to the rear of the pavilion. This passage served both the professor in residence and the students. The large lecture room was located to the right, or north, of the entrance hall. A doorway in the south wall of the entrance hall opened into a stair hall, and that in turn opened into a room that functioned as a dining room or study. These two rooms formed the private domain of the professor on the first floor. Additional rooms intended for the professor's private quarters included the basement kitchen and the second floor parlor and bed-chambers. As the university grew, the lecture room was no longer needed and became part of the professor's residence.

## PAVILION V

The expansion of the pavilion circa 1850 by Professor Harrison increased the first floor area by almost two thirds. The added spaces included a connecting corridor or hyphen as well as a rear stair hall and two large bedchambers.

No other significant changes were made to the first floor until the early years of the twentieth century, probably circa 1903/1929, when the pavilion was modified to function as two separate residences. The work involved the expansion of the circa 1850 connector that joins the front and rear parts of the structure. A formal entrance to the rear building was added to the north side of the connector. Additional spaces, including a room with impressive arched windows, were constructed on the south side of the connector. The original portion of the pavilion was significantly altered by the creation of the arched opening between the entrance hall and the stair hall.

In circa 1929 a covered porch was added to the back of the rear addition. A twentieth-century toilet room was installed at the west end of the pavilion's central hall.

# ARCHITECTURAL DESCRIPTION

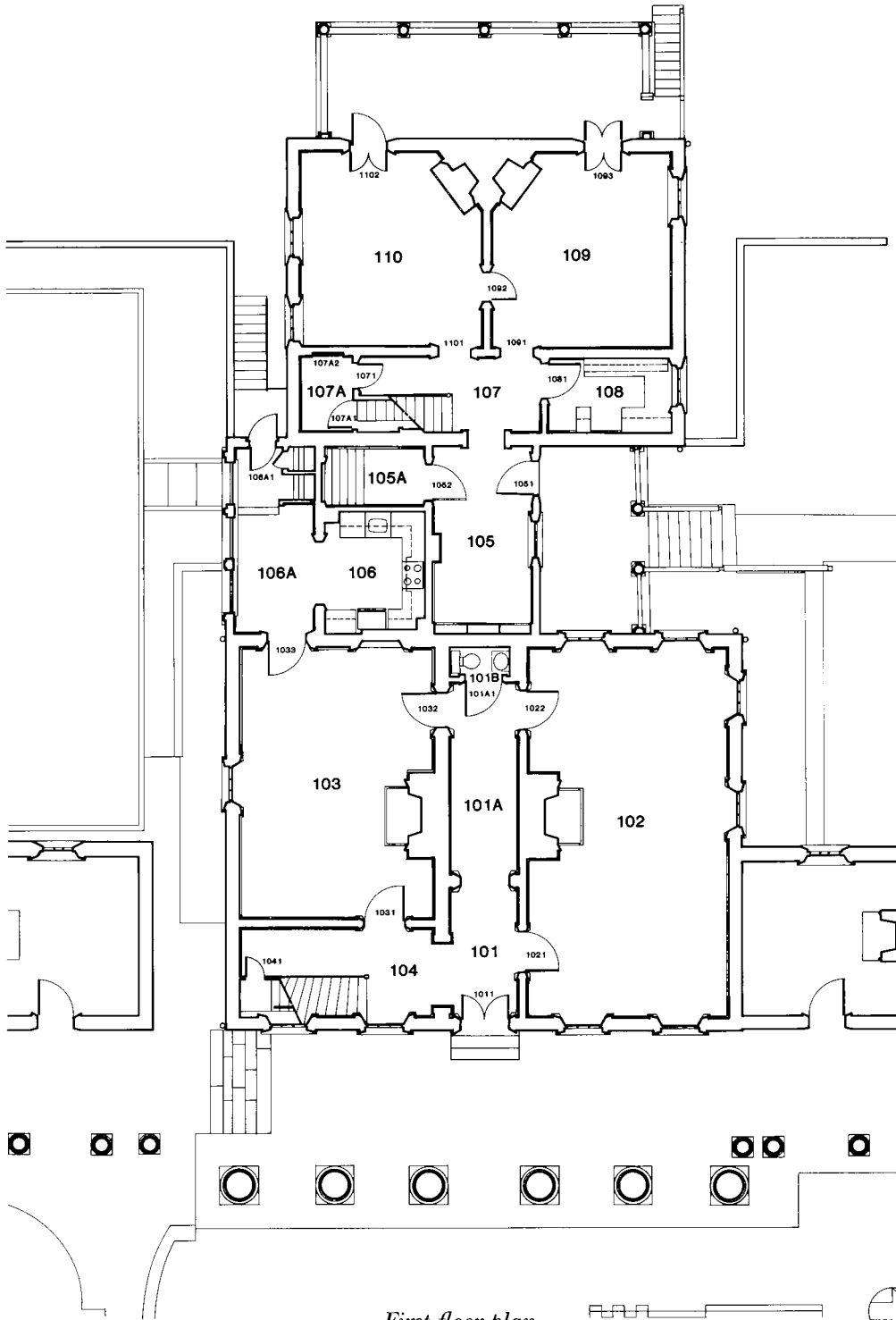

*First floor plan*



## PAVILION V

### ROOM 101 ENTRANCE HALL

The small rectangular entrance hall provides access into the living room (former lecture room) on the north and to the stair hall on the south.

The small size and general appearance of this hall dates to the twentieth century. Originally the hall extended fully through the center of the pavilion from the front entrance to the rear (west) garden entrance. This arrangement is shown on the Jefferson floor plan, as well as on the plan drawn by Cornelia Jefferson Randolph or John Neilson (Randolph-Neilson plan).

The twentieth-century modifications include the elaborate arched opening in the south partition. This impressive feature may have been added as part of the work undertaken circa 1903 when Professor Smith occupied the Pavilion. The arch replaced a doorway that matched the one still in place in the north wall.

The original long hall was shortened when an opening with a glazed transom was installed forming a division between the east and west ends of the space. This insertion may date to work undertaken in 1929, or it may be of more recent origin.

Surviving original architectural finishes include the front entrance doors and architrave, the doorway opening to Room 102, and the cornice, chair rail, and baseboard. In its original form this hall appeared much like the extant hall in Pavilion I.

**Floor:** Random-width (4¼" to 5½") tongue-and-groove boards, running east-west. The boards may be original.

**Ceiling:** Painted plaster, 11' 10½" above floor.

**Walls:** The north wall is original plaster-on-wood lath. The east and south walls are plaster on original masonry. The south wall was disturbed when the archway was inserted, possibly circa 1903. The west partition is a twentieth-century insertion constructed of plaster on lath.

**Baseboard:** 9¼"-high baseboard, including a 6" splashboard with a 3¼" molded top along the north, south, and east walls (Type B-1). There is no baseboard on the west wall. All baseboards are original.

**Chair Rail:** Original 3½"-high molded wood rail (Type T-40).

**Cornice:** 11½"-high painted, unornamented wood cornice (Type C-3). All of the cornice is original except for the section along the west partition that dates to the twentieth century.

**Doors:** Two doorways with painted wood surrounds. The two-leaf entrance door in the east wall



*Rooms 101 and 101A Entrance hall*

has a two-fascia architrave surround (Type T-21) and a rectangular transom with eleven lights formed by semicircular and radiating muntins. Both leaves of the door are painted and grained to resemble mahogany on the interior face and painted deep green on the exterior. The door to the north leading to Room 102 is painted white and has a two-fascia architrave surround (Type T-22). Both of these openings and the doors are original.

Neither of the two additional door openings in the hall has a door. The large, arched opening in the south wall leads into the front stair hall (Room 104) and is trimmed with fluted pilasters supporting a single-fascia architrave. A wood, molded keystone trims the crown of the arch. The wood reveal of the arch is trimmed with recessed panels. This opening may have been created circa 1903 and replaced a doorway identical to door 1021. The opening in the west partition was installed much earlier, perhaps in 1850; details of the original exterior entrance at the east end of the central hall were copied.

No. 1011: Pair of original 1¾" thick stile-and-rail leaves, each with three raised panels (Type D-11).

## ARCHITECTURAL DESCRIPTION

**Hardware:** Each leaf has an original pair of iron butt hinges. The right leaf retains the original upper and lower iron slide bolts. The 4" by 6" iron and brass box lock was installed in the twentieth century. There is evidence on the south leaf for the original 6"-high box lock keeper.

**Lighting:** No artificial lighting remains in the hall. A circular plate on the north wall marks the location of a former wall fixture (removed in 1992). One duplex receptacle in baseboard.

**Paint Investigation:** The hall in its original configuration included the following finishes: the wood trim, including the architraves, cornice, chair rail, and baseboard, was covered in a yellowish white (2.5Y9/2) paint. The top surface of the chair rail and the vertical face of the base were painted in a reddish brown (10R3/2). The paneled doors were finished in a mahogany graining. The plaster walls retain slight evidence of a very light grey (5Y8.5/1) water-based paint followed by the application of wallpaper.

### ROOM 101A HALL

This hall is now completely enclosed, but prior to the nineteenth- and twentieth-century modifications it was opened to the exterior through the original entries at the east (front) and west (rear) ends of the space.

The Jefferson floor plan and the Randolph-Neilson plan do not include the present doorways at the west end of this hall that open into Rooms 102 and 103. The Maverick plan (1822) does include the two doorways, and physical evidence indicates that they are original features. The creation of the small toilet room at the west end of the hall and the insertion of the partition at the east end appear to be concurrent twentieth-century modifications.

**Floor:** Random-width (4¼" to 5½") tongue-and-groove boards, running east-west. The boards may be original.

**Ceiling:** Painted plaster, 11' 10½" above floor.

**Walls:** The north wall is original plaster-on-wood lath. The south wall is plaster on original brick masonry. The east and west partitions of plaster on lath are nineteenth and twentieth-century insertions.

**Baseboard:** Original 9¼"-high baseboard, including a 6" splashboard with 3¼" molded top, along north and south walls (Type B-1). A plain 7"-high splashboard exists on the east partition and a replica of the original baseboard is in place on the west partition. The latter two baseboards date to the twenti-

eth century.

**Chair Rail:** Original 3½"-high molded wood rail (Type T-40). Short sections of rail on the west partition were installed in the twentieth century.

**Cornice:** 11½"-high painted, unornamented wood cornice (Type C-3). The section along the west partition is original but was formerly located on the west wall of Room 101B, the original end of the hall.

**Doors:** Three door openings with painted wood surrounds. The two doors in the north and south walls are painted white; each has a two-fascia architrave surround (Type T-22). The third doorway dates to the twentieth century, when Room 101B was constructed. The east face of the door is painted white, and the west face is painted metallic gold. The door is framed with a two-fascia architrave surround (Type T-FF).

A nineteenth-century door frame to the east separates Room 101A from Room 101. The frame appears to be a copy of the original exterior entrance in the east wall, with a two-fascia architrave (Type T-24) and a rectangular transom with eleven lights formed by semicircular and radiating muntins. Although a wood stop has been installed to accommodate a door within this frame, there are no hinge marks to indicate that a door was ever placed here.

No. 101A1: 1½" thick stile-and-rail door with six raised and beveled panels (Type D-12). This door, an original feature of the pavilion, dates to 1819-23 and was formerly located on the second floor. Hardware: Pair of 4" butt hinges and a 5¼"-high brass or bronze mortise lock stamped "P 10." Each side has a brass or bronze 7" escutcheon plate and 2¼" diameter knob. This hardware dates to the twentieth century. There is evidence that the door originally had a mortise lock and small escutcheon-type keyhole covers.

**Lighting:** No artificial lighting remains in the hall. Electrical wiring and junction boxes remain in the north and south walls for two wall fixtures (removed in 1992). Two duplex receptacles in baseboard.

**Paint Investigation:** The paint evidence found here is the same as described for the entrance hall (Room 101).

### ROOM 101B TOILET ROOM

This small toilet room was created in the twentieth century from what was formerly the west end of the central hall. The doorway in the west wall originally



## PAVILION V

opened to the exterior and the garden beyond. After the circa 1850 rear addition was constructed, the door opened to the connecting passage between the two buildings. When the toilet room was created, the door opening and the adjoining wall were covered over by a partition formed of plaster on expanded metal lath.

*Floor:* Random-width (4¼" to 5½") tongue-and-groove boards, running east-west. This flooring appears to be original.

*Ceiling:* The twentieth-century plaster on expanded metal lath ceiling for Room 101B has been removed, revealing the original split lath, 11' 11" above the floor. The more recent ceiling was 7' 11½" above the floor.

*Walls:* The north, south, and west walls are original plaster on masonry (south and west) and lath (north). The east wall is plaster on expanded metal lath. Before the bathroom was dismantled in 1992, the west wall was plaster on expanded metal lath, furred out from the original west wall approximately 3".

*Baseboard:* The original 9¼"-high baseboard, including a 6" splashboard and a ¾" molded top (Type B-1), runs along the north, south, and west walls. A twentieth-century 5½"-high splashboard runs along the east wall.

*Chair Rail:* The original 3½" molded rail (Type T-40) runs along the west wall. The chair rail has been removed from the north and south walls.

*Cornice:* The original 11½"-high painted, unornamented wooden cornice (Type C-3) runs along the north and south walls at the height of the original ceiling. The south cornice is mitered at the west wall, while the north cornice has been cut off to allow for plumbing risers. The cornice has been removed from the west wall; apparently it was moved to the east face of the partition dividing 101B from 101A.

*Doors:* The door opening in the east partition dates to the twentieth century. The six-panel door is painted white on its east face and metallic gold on its west face and is framed with a plain, 4" wood fascia. The door is an original feature of the pavilion and was formerly located on the second floor.

The opening for the original exterior door remains in the west wall. The opening is framed with a two-fascia architrave (Type T-21) and has a rectangular transom with eleven lights formed by semicircular and radiating muntins.

No. 101B1: The original rear door, which is missing, apparently had a box lock; there is evidence of

the keeper on the architrave. The six-panel door most recently fitted to this opening appears to be the original door from the opening between the second floor stair hall (Room 201) and the hall (Room 202). The door was made narrower to fit the current opening. Hardware: The door retains evidence of original hardware consisting of a 4¾"-high mortise lock.

*Lighting:* There is no artificial lighting existing in this room. A flexible armored cable runs through the north wall to a junction box that served a ceiling fixture until the room was dismantled in 1992.

*Plumbing:* An enameled cast-iron lavatory, marked "11 4 63 4300 12 x 17 Baltimore" and "Made in United States of America by American Radiator & Standard Sanitary Corporation," and an "American Standard" vitreous china toilet were removed from the room in 1992.

The remaining plumbing lines include a copper drain line in the northwest corner of the room, copper hot- and cold-water lines supplying the lavatory at the north end of the room, a water line to the toilet at the south end of the room, and a cap indicating the location of the waste line.

All of this plumbing was installed in the twentieth century.

*Paint Investigation:* The paint evidence found here is the same as described for the entrance hall (Room 101).

### ROOM 102 LIVING ROOM (ORIGINAL LECTURE ROOM)

This large, finely proportioned room is very much like the original lecture room in Pavilion I. It is not known when this impressive room was incorporated into the professor's living quarters. The doors in the south wall give access to the east and west portions of the original central hall. Six original windows provide ample natural light.

All of the architectural finishes are original except the mantelpiece, which was installed in the twentieth century. The appearance of the fireplace prior to this installation remains unknown.

Neither the Jefferson nor the Randolph-Neilson floor plans shows the doorway in the south wall located west of the chimney breast, but the doorway is shown on the Maverick plan of 1822.

*Floor:* Random-width tongue-and-groove boards, running north-south, stained and varnished. This flooring is probably original.

## ARCHITECTURAL DESCRIPTION



*Room 102 Living room*

*Ceiling:* Painted plaster on lath, approximately 11' 11" above the floor.

*Walls:* The north, east, and west walls are plaster on original brick masonry, while the south wall is plaster on wood lath. All of these surfaces are original, although a skim coat of twentieth-century plaster has been applied to some surfaces.

*Baseboard:* Original 8 $\frac{1}{4}$ "-high baseboard, including a 6" splashboard with a 2 $\frac{1}{4}$ " molded top (Type B-2).

*Chair Rail:* Original 3 $\frac{1}{2}$ "-high wood rail (Type T-40).

*Cornice:* Original 11"-high unornamented wood cornice, painted (Type C-3).

*Doors:* Two original door openings in the south wall with two-fascia architrave surrounds (Type T-22).

No. 1021: Original 1 $\frac{1}{2}$ " thick stile-and-rail door with six raised panels (Type D-13). Hardware: Original pair of 5" iron butt hinges and a circa 1929 5 $\frac{1}{4}$ "-high bronze mortise lock stamped "P 10." Each side has a bronze 7" escutcheon plate and 2 $\frac{1}{4}$ " diameter knob. Evidence indicates that the door originally

had a 4 $\frac{1}{2}$ " by 7" iron or brass cased box lock with brass knobs (a 2" rose) and a keyhole escutcheon on the south face.

No. 1022: Original 1 $\frac{1}{2}$ " thick stile-and-rail door with six raised panels (Type D-13). Hardware: Original pair of 5" iron butt hinges and a circa 1929 5 $\frac{1}{4}$ "-high brass or bronze mortise lock stamped "P 10." Each side has a bronze 7"-high escutcheon plate and 2 $\frac{1}{4}$ " diameter knob. There is evidence for two differently sized box locks: a 4 $\frac{1}{2}$ " by 7" box lock and a 5 $\frac{1}{2}$ " by 9 $\frac{1}{4}$ " box lock. The 4 $\frac{1}{2}$ " by 7" lock was probably the earliest.

*Windows:* Two original windows in the north wall and two original windows in the west wall with splayed, paneled reveals at the sides and head and a paneled apron. Above the molded sill the reveals are divided at the level of the meeting rails and each portion has a tall, thin rectangular panel with a small square panel above. Each window is framed with a 6 $\frac{1}{2}$ "-wide two-fascia architrave terminating at splashboard-height plinths, and has a 6/6 double rope-hung sash with 12" by 18" panes,  $\frac{1}{16}$ " muntins,

## PAVILION V



*Room 102 Living room*

and a recent sweep thumb latch on the meeting rails. A new stop bead has been installed at the east window.

Two original windows in the east wall with splayed, plain reveals and a  $6\frac{1}{2}$ " two-fascia architrave surround, terminating at splashboard-height plinths. Each window has 6/6/6 triple rope-hung sash with 12" by 18" panes,  $\frac{3}{16}$ " muntins, and a recent sweep thumb latch on each of the meeting rails.

*Fireplace:* The original 7' 2"-wide chimney breast projects 2' 8" from the south wall. The brick-lined firebox is painted glossy black, and its brick surround is painted matte black. The surround is bordered in turn by an  $8\frac{1}{2}$ " two-fascia architrave molding. Above the architrave is a plain  $5\frac{1}{2}$ " frieze and a  $7\frac{1}{2}$ " denticulated cornice. The wooden mantel is a reproduction, probably installed in the 1950s. The method of construction and lack of paint layering on the mantel confirms the recent origin of this fitting. The bricks of the firebox are approximately  $2\frac{3}{4}$ " by 9" by 4".

*Heating:* One three-column, eighteen-section, cast-iron hot water radiator, marked "American Radiator" and "Peerless," is located between the east windows. A three-column, 11-section, cast-iron hot-water radiator with eleven sections is marked "USRCORP" and is located below the northwest window. A pair of floor-to-ceiling heating pipes in the northwest corner of the room services the radiator in Room 204, while a pair of floor-to-ceiling heating pipes in the southeast corner of the room services the radiator in Room 203.

*Lighting:* There are no electrical lights in this room. A switch with a plastic switch plate is on the wall south of door 1021, and there are nine duplex receptacles in the baseboard and a 220 volt receptacle in the east wall immediately west of the window. A circular metal plate mounted on the south wall between the chimney breast and door 1021 marks the location of an earlier wall fixture.

*Paint Investigation:* Traces of original finishes were found on the various surfaces in this room. The woodwork, including the cornice, was originally

## ARCHITECTURAL DESCRIPTION



*Room 103 Dining room*

covered in a yellowish white (2.5Y9/2) paint. The top surface of the chair rail and the vertical face of the baseboard was finished in a reddish brown (10R3/2) paint. Only minute traces of early finishes were found on the plaster walls, including a bright yellow (5Y9/6) and a purple blue (7.5PB8/2-5PB7/4). Fibers of early wallpaper were also found on the plaster. The two doors were grained to imitate mahogany.

The reproduction mantel is covered in three finishes of cream and white paint.

A comparison of paint layering on the architraves of the two doors revealed that the east opening (door 1021) had eleven-plus layers of finish while the west opening (door 1022) had only five finishes. This may indicate that the west opening is a later insertion as the Jefferson floor plan suggests. The door itself is of the 1819-23 period, and may in fact be the door originally located in the opening between the entrance hall (101) and the stair hall (104). The archway replaced that opening, perhaps circa 1903.

### ROOM 103 DINING ROOM

This large room, an original part of the professor's private living quarters, was designed to serve as the professor's study, but it also functioned as a dining room. Jefferson's plan does not include the doorway in the north wall, which provides access to the west end of the central hall. The Randolph-Neilson plan also omits this door and shows two windows in the south wall rather than the single window that exists today. The 1822 Maverick plan does include the northwest door as it exists today, but that plan also illustrates two windows in the south wall.

Physical evidence indicates that the current arrangement is the original condition.

At least one, and probably both, of the two original window openings in the west wall was converted into doorways when the rear, circa 1850 addition was enlarged circa 1903/1929.

Almost all of the original architectural finishes survive in this important room, including the wooden mantel.

## PAVILION V

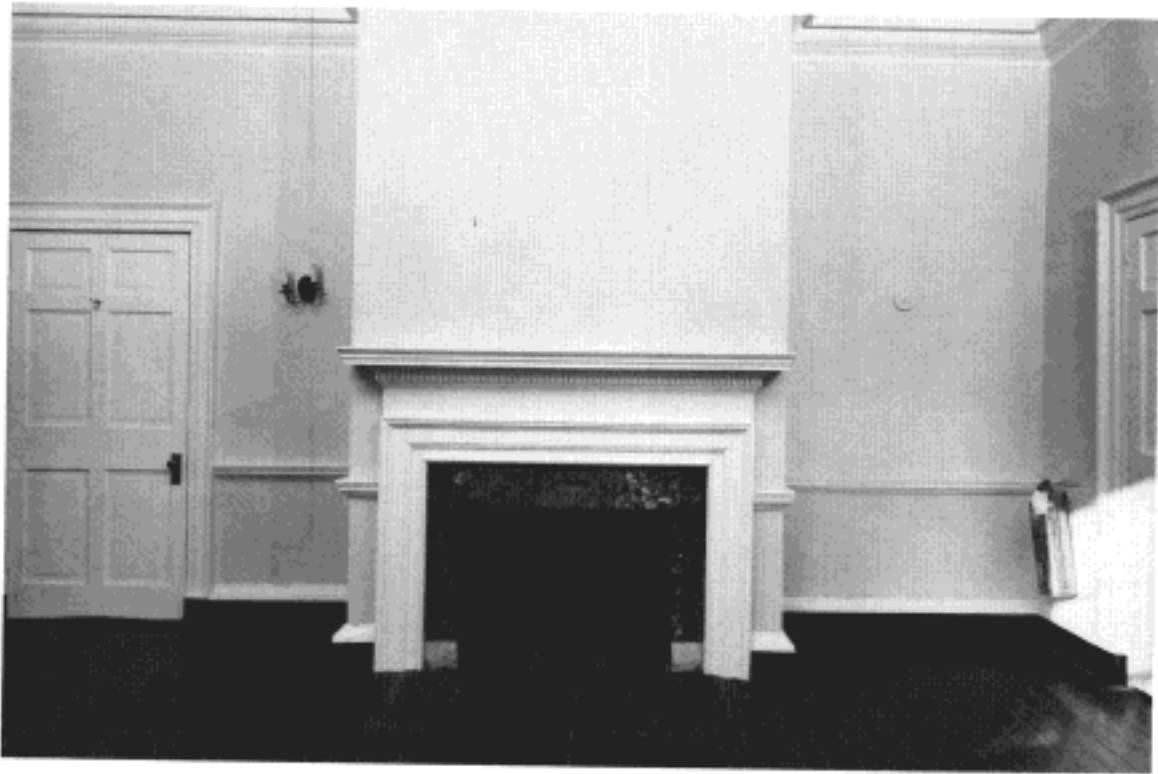

*Room 103 Dining room*

*Floor:* Random-width tongue-and-groove boards, running north-south, stained and varnished. The flooring is probably original.

*Ceiling:* Painted plaster, 11' 10½" above floor.

*Walls:* The north, south, and west walls are original plaster on brick masonry. The west wall was originally an exterior wall. The east wall is original plaster on wood lath.

*Baseboard:* Original 9¼"-high baseboard, including a 6"-high splashboard with 3¼" molded top (Type B-1).

*Chair Rail:* Original 3½"-high wood rail (Type T-41).

*Cornice:* Original painted wood cornice, approximately 11½" high (Type C-3).

*Doors:* One original door opening in the north wall and one original door opening in the east wall, with two-fascia architrave surrounds (Type T-22). A third door has been inserted in an original window opening in the west wall. A wood panel with four raised panels has been inserted above the door to fill in the opening, which is framed by a two-fascia

architrave surround (Type T-23).

No. 1031: Original 1¼" thick stile-and-rail door with six raised panels (Type D-13). Hardware: Original pair of 5" iron butt hinges and a circa 1929 5¼"-high brass or bronze mortise lock stamped "P 10." Each side has a brass or bronze 7" escutcheon plate and 2¼" diameter knob. Evidence reveals that this door originally featured a 5"-high mortise lock.

No. 1032: Original 1¼" thick stile-and-rail door with six raised panels (Type D-13). Hardware: Pair of later 3½" butt hinges and a circa 1929 5¼"-high brass or bronze mortise lock stamped "P 10." Each side has a brass or bronze 7" escutcheon plate and 2¼" diameter knob. A brass hook has been attached to the south face of the door. The door was originally hinged to the east jamb and featured a 5"-high mortise lock.

No. 1033: A twentieth-century 1¼" thick stile-and-rail door with four raised panels (Type D-15). Hardware: Three 6" spring hinges, 3" by 1' 0" chrome push plates, and a foot-operated door stop.

*Windows:* One original window in the south wall

## ARCHITECTURAL DESCRIPTION

with splayed, paneled reveals at the sides and head, a paneled apron, and molded wood sill at the height of the chair rail. Above the sill, the reveals are divided at the level of the meeting rails and each portion has a tall, thin rectangular panel with a small square panel above. The window has a 6½"-wide two-fascia architrave surround (Type T-23) terminating on splashboard-height plinths, and 6/6 double-hung wood sash with 12" by 18" panes, ⅛" muntins, and a recent sweep thumb latch on the meeting rails. A new stop bead has been installed along the east edge of the window.

The paneled reveals and heads of two additional windows remain in the west wall. The northwest window has been filled in with plain wood panels and shelves. Above the shelves, raised paneling has been inserted to fill the remainder of the opening. Prior to the installation of the shelving this opening may have been a doorway dating to circa 1903. The other former window opening has been converted to a doorway (No. 1033).

*Fireplace:* The original 7' 1"-wide chimney breast projects 2' 4" from the north wall. The brick-lined firebox is painted black. Two of the bricks at the back of the firebox are cast with "Powhatan Clay Mfg. Co., Richmond Va."; the bricks on the floor of the firebox are cast with "Penn." An original mottled black marble surround rests on white marble plinths. The marble is bordered by an 8½"-wide two-fascia architrave molding, topped by a 5¼" plain fascia and a 7¼" denticulated cornice. This mantle is original.

*Heating:* A three-column, ten-section, ornamental, cast-iron, hot-water radiator is located below the south window. A similar radiator with 12 sections is set between the west door and the old northwest window opening. Neither of these radiators has any visible manufacturer's marks.

*Lighting:* There are currently no lighting fixtures in the room. A circular metal plate on the north wall east of the chimney breast marks the location of a previous lighting fixture. One electrical junction box in the north wall and four in the south wall serviced twentieth-century wall fixtures that have been removed recently.

Other electrical features include a switch with a plastic switch plate in the east wall south of door 1031, three duplex receptacles in the baseboard, and a 220 volt receptacle in the south wall immediately east of the window.

*Plumbing:* Copper tubing extends from the basement through the floor and through the west wall.

The tubing was used to supply water to an icemaker in the kitchen (Room 106).

*Other Features:* There are seven shelves in the original northwest window opening. The shelves are ¾" high by 11" deep and date to the twentieth century.

A "General" carbon dioxide fire extinguisher is hung from a bracket screwed to the chair rail at the west end of the north wall.

*Paint Investigation:* Traces of original finishes were found on the various surfaces. The woodwork, including the cornice and mantel, was originally covered with a yellowish white (2.5Y9/2) paint. The top surface of the chair rail and the vertical face of the baseboard were finished in a reddish-brown (10R3/2) paint. The plaster walls were covered in wallpaper of which only minute traces were found. The two original doors were grained to imitate mahogany.

The panel above the doorway (formerly a window) in the west wall is covered in three layers of cream and white paint.

### ROOM 104 FRONT STAIR HALL

The stair hall originally provided access to the professor's private quarters on the first and second floors and in the basement. The door in the west wall opened into the professor's study and dining room.

Originally, a doorway separated this stair hall from the entrance hall. The broad arched opening replaced the doorway, perhaps circa 1903. This open arrangement would not have been suitable when the large north room (102) functioned as the lecture room.

All of the original finishes survive here, except for those associated with the replacement of the original doorway in the north wall.

The stair hall follows the configuration shown on the Jefferson and Randolph-Neilson drawings, except for the plan of the staircase. The stairs shown on the two original drawings are arranged in two different manners, and neither includes the angled treads of the stair as actually constructed.

*Floor:* Random-width tongue-and-groove boards, running north-south, stained and varnished. The flooring is original.

*Ceiling:* Original plaster, painted. At the north end of the hall the ceiling is 11' 10¼" above the floor. At the south end of the hall the ceiling follows the slope of the stair carriage and measures 8' 2¼"

## PAVILION V



*Room 104 Front stair hall*

above the floor below the southwest stair landing.

**Walls:** The north, east, and south walls are original plaster on brick masonry. The west wall is original plaster on wood lath. The north wall was modified when the archway was installed, perhaps circa 1903.

**Baseboard:** Between the arched opening in the north wall and door 1031 the baseboard is Type B-2. The remainder of the trim is original 9/16" high baseboard, including a 6" splashboard with a 3/4" molded top (Type B-1).

**Chair Rail:** Original 3/4" high molded wood rail (Type T-40).

**Doors:** One original door opening in west wall with two-fascia architrave surround (Type T-22) and one original door opening beneath the stairs with a 3" wide plain fascia surround. The archway in the north wall replaces an original door opening in the same position. The original door and doorway matched existing door 1031.

No. 1041: Original 1 1/2" thick stile-and-rail door with six raised panels (Type D-19). Hardware: Original pair of 4" iron butt hinges and a circa 1929 5/16"

high brass or bronze mortise lock stamped "P 10." Each side has a brass or bronze 7" escutcheon plate and 2 1/4" diameter knob. There is evidence on the west face for the position of an original 4" by 6" box lock.

**Windows:** Two original windows in the east wall with splayed, plain reveals and 6 1/2"-wide two-fascia surrounds (Type T-23) terminating on splashboard-height plinths. Each window has original 6/6/6 triple rope-hung sash with 12" by 18" panes, 3/16" muntins, and a recent thumb latch on each of the meeting rails. The southeast window extends beneath the stairway and lights the basement stair.

**Staircase:** Original open-string stair with a continuous run of eleven risers to a triangular landing, three risers to a second triangular landing, and six risers to arrive at the second floor stair hall. The treads of the first and last runs are angled, with the first run treads angling from the southeast to the northwest and the last run treads angling from the southwest to the northeast. The stained, varnished, bullnosed treads range from 10 1/4" deep at the interior edge to 11 1/4" deep along the exterior edge. The risers are approximately 8 1/4" high (including a 1" nosing) and are trimmed with a small cavetto molding beneath the nosing. The string brackets are stylized c-scrolls.

The 2" diameter handrail is supported by rectangular 3/8" by 3/8" balusters, spaced approximately 4 1/2" apart (two per tread). The rail is painted dark brown, and the balusters are painted white. A baluster with similar detailing extends across the southeast window. A 2' 3"-wide carpet runner extends the full length of the stairs. The wall surfaces located below the stringers enclose the basement stairway; the original wooden surfaces are divided into rectangular and triangular raised panels.

**Heating:** One three-column, fourteen-section, cast-iron, hot-water radiator is located against the west wall. The radiator is marked "American Radiator" and "Peerless."

**Lighting:** There is no artificial lighting in the hall. Electrical wiring from a wall fixture remains in the west wall south of door 1031. One duplex receptacle in baseboard on east wall.

**Paint Investigation:** Evidence for the original finishes was found on the various surfaces in the hall. The wood trim was first covered in a yellowish white (2.59/2) paint. The stair balusters were covered in the same yellowish white, but the handrail was simply varnished wood. The treads and risers were finished in a moderate brown (5YR4/4). A reddish brown (10R3/2) was applied to the top surface

## ARCHITECTURAL DESCRIPTION

of the chair rail and the vertical face of the baseboard. The plaster walls were first painted in a pale pink (2.5YR9/2) color, followed by a pale yellow (2.5Y9/4). The doors were grained to imitate mahogany.

### ROOM 105 VESTIBULE

This gallery-like space serves as the connector (hyphen) between the original pavilion constructed in 1819-23 and the large rear addition of circa 1850. This connector is contemporary with the rear addition, although the second-story space above this room was increased in height circa 1903/1929.

Originally, the north and south doorways both opened directly to the exterior, probably onto porches and stairs descending to the yard. In circa 1903/1929 the connector was enlarged to the south, causing the south entry to open into an enclosed stairway.

The space primarily served as a connecting passage until circa 1903 when the pavilion was no longer occupied by a single family. Circa 1903, this space became the entry vestibule for the rear portion of the pavilion, which was then occupied by Professor Kent.

The space has continued to serve as the primary entry vestibule for the rear portion of the pavilion.

*Floor:* Original random-width (4½" to 5¾") tongue-and-groove boards, running east-west.

*Ceiling:* Painted plaster on twentieth-century expanded metal lath, which has been applied over the original split lath, 9' 0" above the floor.

*Walls:* Original plaster on brick masonry. The east masonry wall is the original rear (west) exterior wall of the 1819-23 pavilion.

*Baseboard:* Original 5½"-high splashboard with flush bead along top edge (Type B-4).

*Doors:* One original doorway in north wall and one door opening directly opposite in the south wall, with two-fascia architrave surrounds (Type T-26). These openings are contemporary with the circa 1850 construction of the connector and rear addition.

The opening with transom in the east wall is the original (1819-23) rear entry to the pavilion. It became an internal doorway when the rear addition was constructed circa 1850. The opening in the west wall dates to circa 1850 and never included a door.

No. 1051: Original circa 1850 1½" thick stile-and-rail door with four recessed panels (Type D-16). Hardware: Pair of original 3" butt hinges and later

¾" by 6½" iron box lock with brass knobs and oval escutcheon with cover plate. A 2½" by 3½" iron "Corbin" deadbolt with brass knob is surface-mounted to the south face above the box lock. A twentieth-century 2¼" by 6½" brass or bronze mail slot has been inserted in the lock rail. Physical evidence on the lock rails reveals that the door originally (circa 1850) had a 4½" by 6¾" box lock and keeper on the south face and a 2"-high oval keyhole escutcheon on the north face.

No. 1052: Original circa 1850 1½" thick stile-and-rail door with four recessed panels (Type D-16). Hardware: Pair of original 3" butt hinges and a later ¾" by 3¾" iron box lock with brass knobs and small escutcheon. A twentieth-century 2" by 3" iron "Corbin" deadbolt with brass knob is surface-mounted to the north face above the box lock. Physical evidence for the same type of original hardware found on door 1051 was found here.

*Windows:* One original window opening in north wall framed with 6" two-fascia architrave (Type T-26) terminating on 2" thick sill. The original 6/6 double rope-hung wood sash have 12" by 16" panes, ⅙" muntins, and a twentieth-century sweep thumb latch on the meeting rails. There was never a window opening in the south wall.

*Heating:* A three-column, twenty-section, ornamental cast-iron radiator is located beneath window. There are no manufacturer's marks on the radiator.

*Lighting:* There are no lighting fixtures in this room. Electrical features include a switch plate with three switches west of door 1051 and duplex receptacles in the north and east baseboards and in the south wall.

*Plumbing:* A twentieth-century 8" by 2' 6" pipe chase, approximately centered on the south wall, has recently been removed, revealing plumbing risers that serviced the second floor bathrooms (Rooms 206, 207, and 210).

*Other Features:* The electric bell for a twentieth-century doorbell is mounted to the north wall, immediately west of door 1051.

*Paint Investigation:* The white plaster wall surfaces retain paste residue, which indicates that wallpaper was the first finish here. There are only two recent painted finishes on the plaster. The woodwork was first finished in a yellowish white (2.5Y9/2). The baseboard was covered in a grey (10YR6/1) finish. Two successive layers of graining cover the doors; the first may imitate oak, and the second is a mahogany finish. A very dirty soot-like layer covers the second paint layer in this room.



## PAVILION V

### ROOM 106A BREAKFAST ROOM

The three large, south-facing windows provide an abundance of natural light and indicate that this room may have been used as a conservatory with access from the dining room. A circa 1920 aerial view of the pavilion clearly shows this addition; if the photograph is correctly dated, this room and the adjoining space (106) may have been constructed circa 1903 when the pavilion was modified for the joint occupancy of Professors Smith and Kent. At that time, the kitchen was probably still in the basement (Room B05). If in fact the photograph is of a later date, then the construction may have occurred in 1929.

At some later date the large opening in the north wall was created and the swinging door was installed in the east opening. Unfortunately, no documentation has been found to confirm the dates for any of this work.

*Floor:* Circa 1903 2½" subfloor boards, running east/west. At the west end of the room, the floor steps up to a platform raised 10½" above the floor. The platform is surfaced with ¾"-wide tongue-and-groove boards. This platform was constructed when the doorway was created in the west wall sometime after the creation of the room. The floor appears to have been covered with vinyl (removed in 1992).

*Ceiling:* Painted plaster, 12' 3" above floor.

*Walls:* The walls are plaster on brick masonry and primarily date to circa 1903/1929, except for the east wall, which was part of the brickwork of the 1819-23 pavilion, and the north half of the west wall, which dates to the construction of the rear addition circa 1850. Until 1992 there were two plaster-on-lath partition walls enclosing a small closet in the northwest corner of the room.

*Baseboard:* 5½"-high splashboard with molded top (Type B-4), dating to circa 1903/1929 or later.

*Doors:* One door in the west wall leading to exterior stairs, framed with a single-fascia architrave surround (Type T-34). This door opening was probably created circa 1929 or later from what was a window opening. The opening did not extend to the floor, making the inserted floor platform necessary.

A swinging door has been inserted in an original 1819-23 window opening in the east wall. A wood infill panel with four raised panels had been installed above the door. The opening has a two-fascia architrave surround (Type T-2). The door dates to circa 1929 or later.

Until 1992 there was a doorway opening into the

former closet in the northwest corner of the room. The opening was framed with a 3"-wide single-fascia architrave with a plain, beveled perimeter molding.

No. 106A1: A circa 1929 (or later) 1¼" thick stile-and-rail door, with 15 lights above a raised panel (Type D-14). The panes are 6" by 9" and the muntins are ¾" wide. Above the door there is a six-light fanlight. Hardware: Pair of 2¾" butt hinges and a 5½" bronze mortise lock stamped "P 12." Each side has a bronze 7" escutcheon plate and 2¼" diameter knob. A 3½" bronze "Corbin" deadbolt with a cast-iron casing is surface mounted to the east face.

On the exterior side of the opening there is a 1" thick stile-and-rail door with two screened panels. Hardware: Pair of 2¾" iron/steel spring hinges and a bronze mortise latch. A 3" steel slide bolt is surface mounted to the east face; physical evidence indicates the bolt has been moved down approximately 1".

No. 106A2: This 1½" stile-and-rail door with two recessed panels was removed in 1992.

*Windows:* Three circa 1903/1929 arched windows in south wall, framed with 5"-wide single-fascia architraves with 2"-wide beveled perimeter moldings. The architraves terminate on a continuous 1¼" thick bullnosed sill and 3½"-high apron. Each window features 25/25 double rope-hung sash below a fixed, nine-light fanlight. The panes of the 25/25 sash are 6" by 8", and the muntins are ⅝" wide. There is a sweep thumb latch on each of the meeting rails.

*Heating:* Five column, 40-section cast-iron, hot-water radiator beneath windows.

*Lighting:* There is currently no artificial lighting in the room; a ceiling fixture was removed in 1992. Electrical elements include switches on the east and west walls, a duplex outlet in the south wall, and a grounded duplex outlet surface mounted to the south wall with rigid conduit running down to the basement.

*Plumbing:* Capped-off domestic waste and supply lines remain in the north wall, to the west of the opening into Room 106. Until 1992 these lines were covered by a horizontal wood fascia.

*Other Features:* There is a set of five steps in the northwest corner of the room, rising from south to north. The steps are approximately 5' 3" wide, with 8½" treads (including a ½" nosing) and 7" risers (including a ¾" nosing). The east face of the stairs is enclosed with a vertical, beaded-board partition. Until 1992 the west half of the steps was enclosed within a closet, and the east half of the steps was cov-

## ARCHITECTURAL DESCRIPTION

ered by casework. As originally constructed circa 1903/1929 the "steps" were fully exposed with a semi-circular window in the wall above the steps. This arrangement was constructed to cover the stairwell below and to provide light to the stairway in Room 105A. The short flight of "steps" served as shelving. The platform was constructed when the west exterior door was created from what was formerly a window.

*Paint Investigation:* The circa 1903/1929 wood trim was first finished in a yellowish white (2.5Y9/2) paint followed by at least 12 more finishes. The eighth finish, a light grey, is the first finish on the trim of the wide opening in the north wall.

### ROOM 107 REAR STAIR HALL

The stair hall serves as the point around which all of the rooms in the rear addition are arranged. Prior to the twentieth century, the stairway did not continue to the basement. The small horizontal window opening, which now provides natural light to the hall and to the stairway, was inserted in the twentieth century, probably circa 1903/1929. Evidence for an earlier window condition has not been found.

The circa 1850 staircase was obviously modeled on the original (1819-23) stair in the front of the pavilion.

*Floor:* The original, circa 1850 flooring survives.

*Ceiling:* Original, circa 1850 painted plaster, 9' 11½" above floor.

*Walls:* The east, west, and south walls are original plaster on brick masonry. The north wall is plaster on wood lath.

*Baseboard:* Original 5¼" splashboard with a flush bead along the top edge (Type B-4).

*Doors:* One original doorway in north wall, two original doorways in west wall, and a twentieth-century doorway in the south wall, each with a two-fascia architrave (Type T-26). The opening in the east wall is also original. It never included a door.

No. 1071: A twentieth-century 1⅜" thick stile-and-rail door with four recessed panels (Type D-17). Hardware: Pair of 3" butt hinges and a 3¼" by 3¼" iron box lock with brass knobs. The south face of the door has a small metal keyhole escutcheon. The door opening was created circa 1903 or 1929 in what was originally a solid partition.

*Windows:* The rectangular, pivoting window in the south wall at the level of the stair landing provides some natural light for the hall.

*Staircase:* Open-string stair with a straight run of

11 risers to arrive at the south landing and a straight run of six risers returning north to arrive at the second floor stair hall (Room 209). The treads are 3' 2" wide by 10¾" deep, including a 1" nosing, and the risers are 7½" high, including a 1" nosing. A small (⅝") cavetto molding has been applied beneath each tread. The stairs have stylized c-scroll string brackets. The 2¼" diameter handrail is supported by 7⁄8" by 1⅛" balusters spaced 4½" to 5" apart (two per tread). The wall surface below the stringer is plaster on lath. This stair is original to the rear addition and dates to circa 1850. It is similar in detail to the stair in the original (1819-23) portion of the pavilion.

*Lighting:* There are no lighting fixtures in the hall. Other electrical features include a junction box for a wall sconce between doors 1091 and 1101 and switches on the north and east walls.

*Paint Investigation:* The original finishes found in the hall date to circa 1850. The trim, including stair newels and balusters, was first finished in a yellowish white (2.5Y9/2) paint. The simple baseboard and the stair risers were painted gray (10YR6/1). The handrail was varnished, and traces of varnish were found on the treads. The plaster walls were covered with wallpaper; tiny fragments showed a pink-and-gray ground with a gray-and-white imprint.

### ROOM 107A LANDING

Originally this small space was an under-stair closet with access from Room 110 through a doorway in the west wall. That door is still in place, but the opening has been covered over in Room 110. It was probably about 1903, when the rear addition was converted into a separate residence, that the stairway to the basement was created. At some later date, perhaps circa 1929, the doorway opening to the stair hall (107) was created.

*Floor:* Original 4½" to 5½" wide floorboards, running north/south. The floorboards appear to be continuous from Room 107. The floor directly under the lower run of the stair was cut out when the basement stairway was installed.

*Ceiling:* Plaster on lath, 6' 4" above floor. This is the original circa 1850 surface.

*Walls:* The north wall is paneled with vertical, beaded boards. The south and east walls are original plaster on masonry. North of door 107A2 the west wall is covered with vertical, beaded boards on masonry, while south of the door the wall is plaster on masonry.

## PAVILION V



*Room 107 Rear stair hall*



*Room 108 Kitchen*

*Baseboard:* Original 5½" splashboard with flush bead along top edge (Type B-4) on east and south walls and on the west wall south of Door 107A2.

*Doors:* Two later door openings in the north wall and one original door opening in the west wall. The northeast opening has a plain fascia surround at the top and on the east side. The original west door is set flush with the wall and is no longer operable. The opening has a plain fascia with a flush bead at the south end of the door.

No. 107A1: A circa 1903 1¾" thick stile-and-rail door with four raised panels (Type D-18). Hardware: Pair of 3½" butt hinges and a 5½" bronze mortise lock with brown mineral knobs. The knobs are older than the lock. There is a 2¼" by 7¼" metal escutcheon plate on the south face of the door, and a wood cleat with a 3" steel slide bolt is mounted to the north face of the door.

No. 107A2: An original circa 1850 stile-and-rail door with four recessed panels (Type D-28). Hardware: All of the original and later fittings are missing. There is evidence on the north end of the lock rail for the original Carpenter-type box lock. There

is evidence on the south end of the lock rail for a later 3¼"-high Victorian box lock.

*Lighting:* Electrical elements include a porcelain light socket mounted to the ceiling, a switch in the north wall, and rigid conduit running through the west wall.

*Other Features:* A 1' 7½"-deep shelf on the south wall is supported by wood cleats on the east and west walls.

### ROOM 108 KITCHEN

This small room may have served as a kitchen as early as circa 1929, when the rear portion of the pavilion was occupied by Professor Sparrow, but the earlier and original function for this room remains unknown. When the adjoining larger rooms functioned as bedchambers in the nineteenth century, this room may have been a bathing room, a dressing room, or a small bedroom. Evidence in the floor framing indicates that a stairway to the basement may have been located here.

Most evidence for earlier uses was destroyed

## ARCHITECTURAL DESCRIPTION

when the most recent kitchen fittings were installed.

The door was originally hinged so that it opened toward the east wall rather than against the west wall, as it currently does.

*Floor:* 3"-wide pine flooring, running north-south. This flooring was installed in the twentieth century. The framing of this floor can be seen in the basement. Two joists, inserted after the other framing, may be in the position of an original stair opening.

*Ceiling:* Original plaster, painted, 9' 11" above floor.

*Walls:* The north, east, and west walls are circa 1850 plaster on brick masonry. The south wall is circa 1850 plaster on lath. The wall within the cabinet on the north wall is covered with recent plaster on expanded metal lath.

*Baseboard:* A 5½"-high splashboard with a bead at the top edge has been removed from the south, east, and west walls.

*Doors:* One original doorway in south wall with a two-fascia architrave surround (Type T-26).

No. 1081: An original circa 1850 1¼" thick stile-and-rail door with four recessed panels (Type D-30). Hardware: Pair of 3" butt hinges and a ¾" by ¾" iron box lock with pair of brass or bronze knobs. The door was originally hinged to the opposite jamb, and the molded panels faced south. Originally a 4" by 4¾" box lock was mounted on the plain, north face (Room 108 side) of the door.

*Windows:* One original window opening in the north wall, framed with a 6"-wide two-fascia architrave (Type T-26). The architrave has been cut off at the height of the twentieth-century counter splash-guard, approximately 3' 5½" above the floor. The window extends down another 6" to a sill that has also been cut off. The original 6/6 double rope-hung wood sash have 12" by 16" panes, ⅜" muntins, and a bronze sweep thumb latch on the meeting rails.

*Lighting:* Fluorescent lighting fixture surface mounted to ceiling. Other electrical elements include a switch east of Door 1081, three duplex receptacles in the east and west walls, and an electrical receptacle for a range.

*Plumbing:* Double basin, enameled, cast-iron sink marked "Kohler USA, 5950, 42x21-2S, 7 16 56." Copper cold-water line in east wall to service ice-maker.

*Other Features:* There are 2' 1½"-deep cabinets on the north and east walls and a similar 1' 0"-deep cabinet on the west wall. The cabinets are finished with pink plastic-laminate counter tops, and the plain

wood doors have chrome pulls and small 2½" butt hinges. Along the east wall a 1' 0" deep by 5' 5" high upper cabinet is mounted flush with the ceiling. Beneath this cabinet a "Rangaire" stove hood remains in place. All of these fittings were installed in the mid-twentieth century or later.

### ROOM 109 DINING ROOM

The intent of the circa 1850 construction of the rear addition was to provide more living space for Professor Harrison's large family. This ample room probably served as a bedchamber at that time. Originally, there was no connection between this room and Room 110. The existing door and the doorway between Rooms 109 and 110 may have been removed from the partition separating Rooms 211 and 212 and installed on the first floor, circa 1903. When the rear porch was constructed, circa 1929, the French doors were installed in the original west window opening.

The room probably functioned as a dining room for Professors Kent, Sparrow, and Abernathy as well as for Professor Redmond.

*Floor:* Original random-width, tongue-and-groove boards, running east-west.

*Ceiling:* Original plaster, painted, 9' 9" above floor.

*Walls:* Original plaster on brick masonry.

*Baseboard:* Original 5¾"-high splashboard, with a flush bead along the top edge and a flattened shoe molding along the bottom edge (Type B-4).

*Doors:* Three door openings with two-fascia architrave surrounds (Type T-26). The doorway in the east wall is an original circa 1850 opening. The west door opening dates to circa 1929 and was created in what was an original window opening. The south door opening has a paneled reveal. This doorway was installed here in the later nineteenth century, or perhaps circa 1903. The architrave may have been removed from an original position in the partition separating Rooms 211 and 212.

No. 1091: Missing. The door here would match the door in place in opening No. 1081 (Type D-30).

No. 1092: A circa 1850 1¼" thick stile-and-rail door with four recessed panels (Type D-20). This door may have been a former opening between Rooms 211 and 212. Hardware: Recent pair of 3½" butt hinges and ¾" by 4½" iron box lock with brass or bronze knobs and keyhole escutcheon. The door was originally hinged on the opposite stile with 3" hinges, and there is evidence on the lock rail for an

## PAVILION V

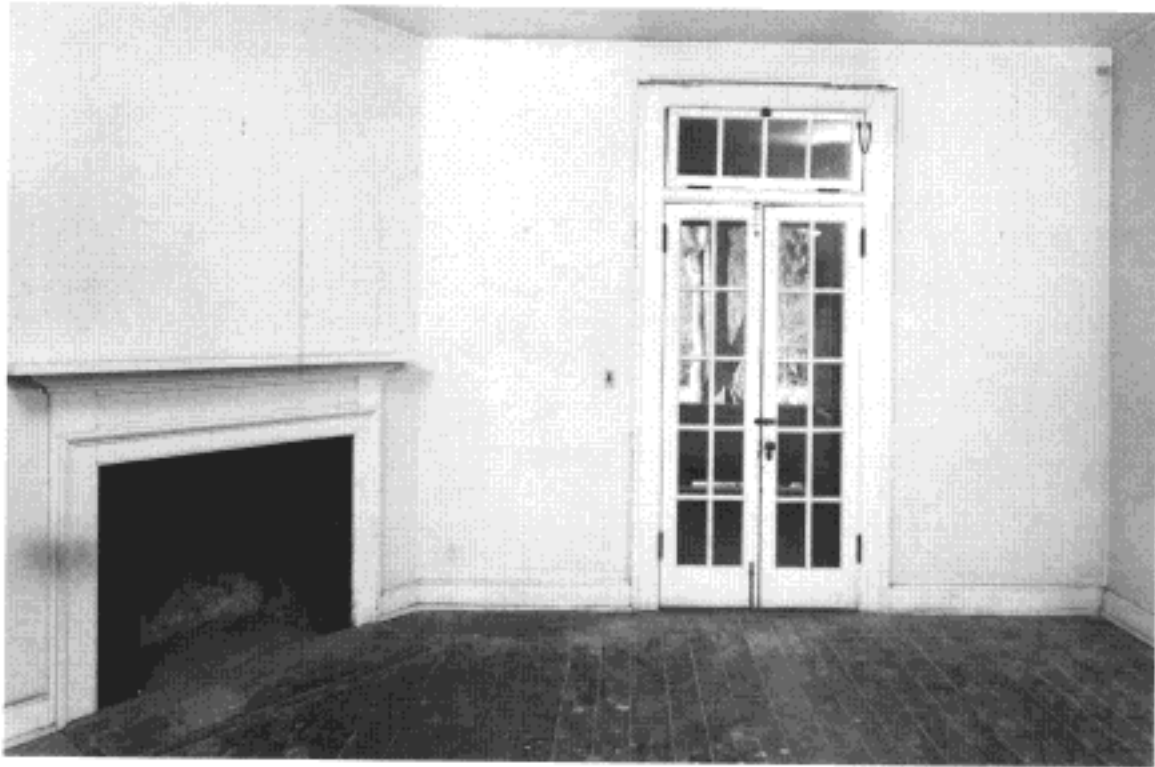

*Room 109 Dining room*

original 4" by 4½" box lock (possibly a Carpenter-type lock).

No. 1093: Circa 1929 pair of 1¾" thick stile-and-rail glazed doors (Type D-24). Each door has ten lights, with 7" by 14" panes and 1½" muntins. A four-light rectangular transom above the doors has 8½" by 12" panes and 1½" muntins. Hardware: Pair of 4½" brass or bronze butt hinges with ball tips at each door. The north leaf has a 5" mortise lock with brass or bronze knob and escutcheon on interior face and a brass or bronze latch and escutcheon on west face. South leaf has 3¾" mortised keeper, 3" slide bolt on lock stile, and 9½"-high brass or bronze slide bolts surface mounted to top and bottom rails (these are replacements; evidence on the door indicates that 9" bolts, similar to those on Door 1102, were originally used). Transom sash has pair of 3½" butt hinges at bottom rail, a 1½" latch at top rail, and a chain at the north stile.

A pair of 1" thick stile-and-rail screened doors has been installed at the west edge of the door opening. Hardware: Pair of 2½" butt hinges on each leaf,

a "Weiser" brass or bronze mortise latch in north leaf, and a keeper mortised into south leaf.

*Window:* One original circa 1850 window opening in the north wall, framed with a 6"-wide two-fascia architrave (Type T-26) terminating on a 1" thick sill above a ¾" cavetto molding. The stop beads are missing. The sash cords for the original 6/6 double rope-hung window sash are missing. The sash have 12" by 16" panes, ¾" muntins, and a sweep thumb latch on the meeting rails.

*Fireplace:* The original masonry chimney breast extends diagonally across the southwest corner of the room, approximately 6' 0" wide. The firebox is built of 2½" by 8" bricks, painted black. A plaster surround is bordered by a 6"-wide fascia with a 2" ogee perimeter molding. Above the surround is a 5½" frieze with a plain, recessed panel. The cornice is 4½" high. A brick hearth, made of 3½" by 7¾" bricks, is painted black. Stylistically, the mantel appears to date to the early nineteenth century rather than circa 1850, and it is very different in character from the mantels on the second floor; it is more

## ARCHITECTURAL DESCRIPTION

likely that it is a circa 1903 revival of the early mantel form. However, the paint layering on the mantel suggests that it dates to circa 1850, further confusing the mantel assessment.

*Heating:* A three-column, ten-section ornamental, cast-iron hot-water radiator sits below the window. There are no manufacturer's marks on the radiator.

*Lighting:* There are no lighting fixtures in the room. Wiring from the fixtures removed in 1992 remains in the ceiling and in the south wall, and two metal plates on the east wall cover junction boxes for fixtures removed in 1992. Other electrical elements include a switch and dimmer control north of door 1091, a switch on the west wall, a switch plate on the south wall, two duplex receptacles in the east wall, and one duplex receptacle in the north baseboard.

*Paint Investigation:* The interpretation of the paint layering in this room is complicated by the various modifications that have been made, beginning circa 1903. The circa 1850 woodwork was first finished in a yellowish white (2.5Y9/2) paint very much like the original and subsequent yellowish white used in the original 1819-23 portion of the pavilion. The baseboard was covered with a gray (10YR6/1) color, and the original door was grained to imitate what may be oak. The earliest finish on the mantel is a glossy black, and it probably dates to circa 1850. The door trim on the south wall is covered in layers of yellowish whites, and the paneled door retains evidence for oak graining. The trim of the glazed doors in the west wall includes three finish layers; the first is a yellowish white.

The plaster walls were first finished with wallpaper, followed by a pale gray (5YR8/1) paint.

### ROOM 110 PARLOR

Upon the completion of this room circa 1850, it served as a bed chamber. At the south end of the east wall, a doorway provided access to a closet located beneath the hall stairway.

After the circa 1903 renovations and the occupancy by Professor Kent, the room may have been used as a parlor, with the adjoining and newly connected space (Room 109) functioning as a dining room. It is also possible that these uses were reversed.

The exterior French doors were installed in the original west window opening when the rear porch was constructed, circa 1929.

*Floor:* Original random-width, tongue-and-groove

boards, running east-west.

*Walls:* Original plaster on brick masonry. A closet door opening at the south end of the east wall was covered over circa 1929.

*Ceiling:* Original plaster, painted 9' 9" above floor.

*Baseboard:* Original 5½"-high splashboard with a flush bead at the upper edge (Type B-4). A break in the east baseboard, 4' 1½" from the south wall, relates to the original door opening in that wall.

*Doors:* Three doorways with two-fascia architrave surrounds. The north door opening has a paneled reveal and may have been inserted in the wall circa 1903. The doorway in the west wall was created circa 1929 in what was an original window opening.

No. 1101: Door is missing. The door was probably removed in the twentieth century when the room became a parlor. The jamb retains an iron-and-brass keeper, 4⅛" high, for a Carpenter-type box lock.

No. 1102: Pair of circa 1929 1¾" thick stile-and-rail glazed doors (Type D-24). Each door has ten lights, with 7" by 14" panes and 1⅛" muntins. A four-light rectangular transom above the doors has 8½" by 12" panes and 1⅛" muntins. Hardware: Pair of 4½" brass or bronze butt hinges, with ball tips, at each door. The north leaf has a 5" mortise lock with bronze knob and escutcheon on the east face and a brass or bronze latch and escutcheon on the west face. South leaf has 3¾" mortised keeper and 9"-high brass or bronze slide bolts surface mounted to top and bottom rails. Transom sash has pair of 3½" butt hinges at bottom rail, a 1½" latch at top rail, and a chain at the north stile.

A 1" thick stile-and-rail screened door has been installed at the west edge of the door opening. Hardware: Pair of 3" spring hinges, a 4" pull, and a hook-and-eye catch.

*Windows:* Two original circa 1850 window openings in the south wall, framed with 6"-wide two-fascia architrave terminating on 1¾" thick sills. The original window sash are 6/6 double rope-hung sash; they have 12" by 16" panes, ⅝" muntins, and brass sweep thumb latches on the meeting rails. A third original window opening in the west wall was converted into a doorway circa 1929.

*Fireplace:* The original masonry chimney breast extends diagonally across the northwest corner of the room, approximately 6' 0" wide. The firebox is built of 3½" by 7¾" bricks painted black. A plaster surround, painted black, is bordered by a 6" fascia with a 2" ogee molding. Above the surround is a 5¾"

## PAVILION V

frieze with a plain, recessed panel. The cornice is 4¼" high. A brick hearth, made of 3½" by 7¾" bricks, is painted black. Paint layering indicates that the wooden mantel may date to circa 1850, although stylistically it appears older. It is likely that the mantel is a circa 1903 revival of the early mantel form. Nail types used in the construction of the mantel need to be analyzed to determine the period of this fitting, as well as that of the mantel in Room 109.

*Heating:* A three-column, ten-section cast-iron hot-water radiator is located below the southeast window. There are no manufacturer's marks on the radiator.

*Lighting:* Electrical elements include a switch south of door 1101 and four duplex receptacles in the baseboard.

*Paint Investigation:* The changes made to the room circa 1903 and 1929 became apparent from the paint layering on the various surfaces. The original wood trim was first finished with a yellowish white (2.5Y9/2) used at various times throughout the pavilion. The baseboard was painted gray (10YR6/1) and the northeast door (now missing) may have been grained to imitate oak. The layering on the mantel includes a brown (5YR5/2) paint, then a glossy black, followed by a layer of graining and three layers of white.

Wallpaper was used as the first finish on the plaster walls, followed by layers of various white paints. There were probably several wallpapers used here; the wallpaper may have been painted over and removed prior to the application of the most recent paints.

## ARCHITECTURAL DESCRIPTION

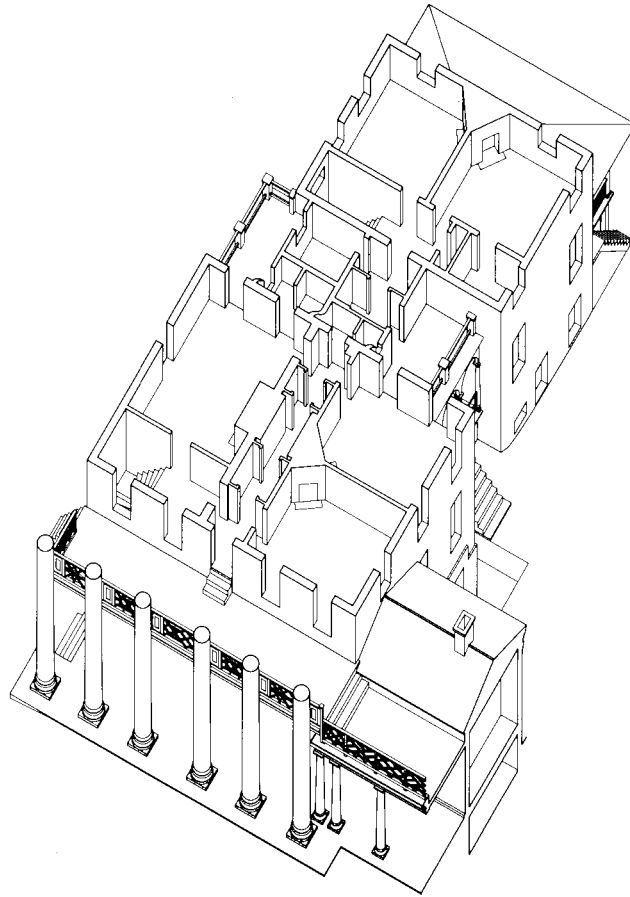

SECOND FLOOR

The second floor of the original pavilion retains most of its original character. The plan as it exists duplicates the original Jefferson floor plan. The only exceptions are the brick chimney masses in each room, where stoves were shown on the original plan. As constructed, fireplace masses were placed in each room; cast-iron Franklin stoves may have been installed in the fireplace openings.

In plan, the second floor includes a central hall, which extends from the front to the rear of the pavilion. The most distinctive feature in the hall is the tall, arched masonry opening through the central chimney mass. North of the passage are two bedchambers, each with a corner fireplace. Originally these rooms were joined by a doorway in the partition that separates them. South of the passage there is the



## PAVILION V

stair hall and the large formally detailed room that functioned as the professor's parlor. As in all the pavilions, the latter room features a finely detailed entablature.

The expansion of the pavilion circa 1850 resulted in the addition of two large bedchambers, a dressing room, and a stair hall at the west end of the second floor. Later, a bathroom and closet were built in the dressing area. These were joined to the original pavilion by a connecting corridor that had a very low ceiling and a large opening in the south wall.

Additional modifications were made in the early twentieth century, probably circa 1903/1929, when the connector was enlarged. This work included the raising of the roof to a higher level and the addition of two rooms on the south side of the connector; one of these rooms was fitted as a bathroom, either then or later.

Two bathrooms were installed in the original portion of the connector during the twentieth century.

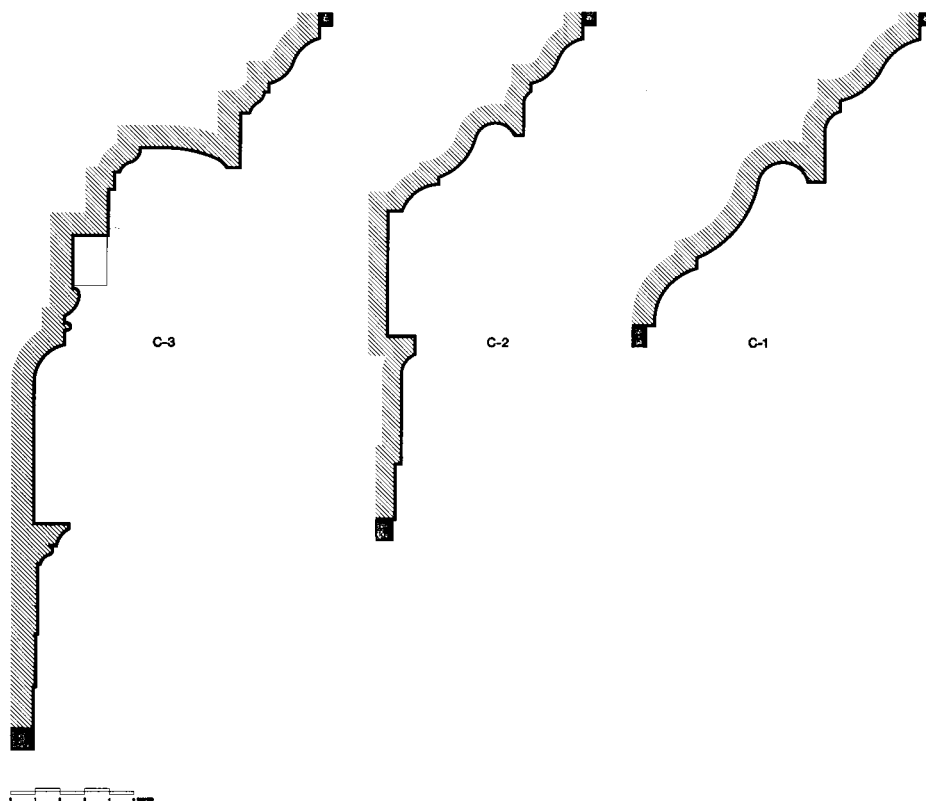

*Room cornice profiles*

# ARCHITECTURAL DESCRIPTION

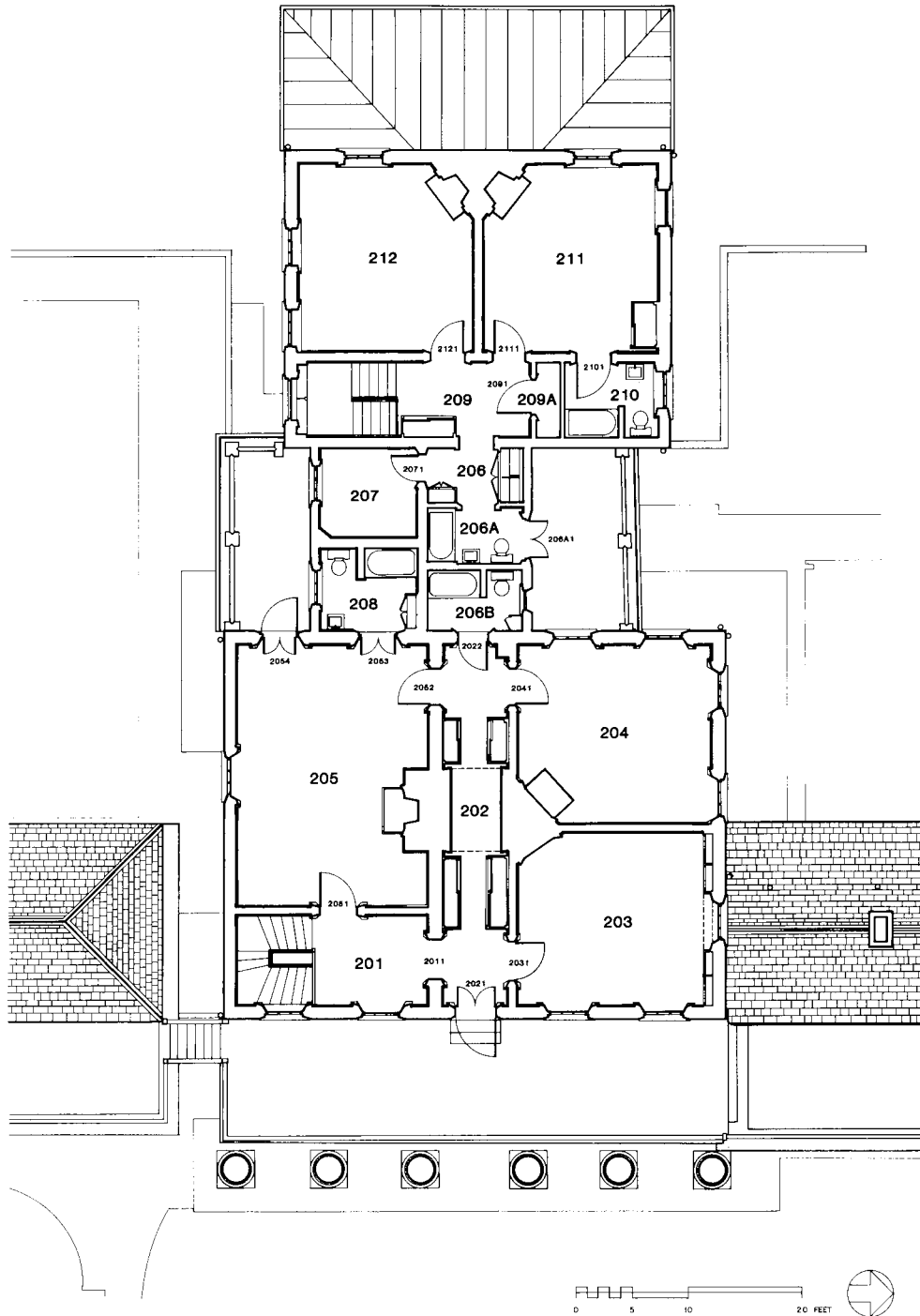

*Second floor plan*

## PAVILION V



*Room 201 Front stair hall*

### ROOM 201 FRONT STAIR HALL

The stair hall has always been part of the professor's private domain. The stairway ascends from the first floor and doorways open from the hall to the original parlor (205) and to the central corridor (202). Four windows provide natural light to the stairway as it ascends from the first floor to the second floor. The plan of the hall follows that delineated by Jefferson; the only difference is in the configuration of the stair treads. Jefferson drew the treads perpendicular to the stair stringers, with winders at the south wall to return the stair carriage. As built, the treads were skewed.

*Floor:* Original random-width, tongue-and-groove boards, running north-south, stained and varnished.

*Ceiling:* Original plaster on lath, painted, approximately 10' 8" above the floor.

*Walls:* The south, east, and north walls are original plaster on brick masonry. The west wall is original plaster on wood lath.

*Baseboard:* Original 8 $\frac{1}{2}$ "-high baseboard, includ-



*Room 202 Hall*

ing a 6" splashboard and a 2 $\frac{1}{4}$ " molded top (Type B-2).

*Cornice:* Original 2' 3"-high wood entablature, composed of a three-fascia architrave, a plain coved frieze, and a denticulated cornice (Type C-1).

*Doors:* Two original door openings, one in the north wall and one in the west wall, with two-fascia architraves (Type T-35). The reveal of the north opening is faced with recessed paneling; the door has been removed.

No. 2011: Door is missing. The six panel door that was slightly cut down at the sides and placed in the first-floor doorway No. 101B1 was probably located here.

*Windows:* Two original window openings in the east wall with splayed paneled reveals and paneled heads are framed with 6 $\frac{1}{2}$ "-wide two-fascia architraves terminating at splashboard-height plinths (Type T-36). The reveals are divided at the level of the meeting rails, and each portion has a tall, thin rectangular panel with a small square panel above. Each opening has original 6/6 double rope-hung sash, with 12" by 18" panes and  $\frac{3}{8}$ " muntins. Hard-

## ARCHITECTURAL DESCRIPTION

ware includes recent sweep thumb latches on the meeting rails.

*Staircase:* The original stair from the first floor is terminated in the southwest corner of the room. The baluster railing continues across the stair opening to the east wall, where it is supported by a turned newel post.

*Heating:* The only heat for the space is supplied by the single radiator in the first floor stair hall (Room 104).

*Lighting:* There is no artificial lighting. Wiring in the wall west of the stairwell and a junction box mounted in the ceiling serviced lighting fixtures removed in 1992. Other electrical elements include a pair of switches with plastic switchplates flanking door 2051 and two duplex receptacles in the baseboard.

*Paint Investigation:* The finish evidence found here follows that uncovered in the first floor stair hall (104). All of the wood trim, including the massive entablature and the stair balusters, was originally covered with a yellowish white (2.5Y9/2) paint. The vertical face of the baseboard was painted with a reddish-brown (10R3/2) paint, and the doors were grained to imitate mahogany.

Traces of original and early finishes found on the plaster wall surfaces include a pale pink (2.5YR9/2), a pale yellow (2.5Y9/4), and evidence of wallpaper.

### ROOM 202 HALL

This tall, narrow hall retains most of its original character. The arched opening that joins the two chimney masses is a dramatic feature. The window at the west end of the hall was removed when the rear addition and connecting hyphen were constructed circa 1850. The loss of natural light may have prompted the insertion of glazed panels in the original paired doors at the east end of the hall.

*Floor:* Original random-width (4½" to 6"), tongue-and-groove boards, running east-west, stained and varnished.

*Ceiling:* Original plaster on wood lath, painted, 10' 8" above the floor. An access panel at the west end of the ceiling opens into the attic. This opening was the original access to the "flat" roof of the pavilion that survives in the attic created when the hipped roof was installed in 1837. This opening was modified in 1993 when it was enlarged to accommodate the installation of HVAC equipment in the attic.

*Walls:* The south, east, and west walls are original plaster on brick masonry. The north wall is original plaster on split-wood lath. The chimney masses from the fireplaces in Room 205 to the south and Rooms 203 and 204 to the north project into the hall and are joined by a 7' 1"-wide plastered masonry arch. The arch is trimmed with 6½"-wide architraves terminating at bull's-eye corner blocks at the arch imposts. The profile of the trim and the corner blocks is the same.

*Baseboard:* Original 8¼"-high baseboard, including a 6" splashboard and a 2¼" molded top (Type B-2).

*Cornice:* Small, 2" wood molding. This is a later insertion.

*Doors:* Five original door openings, two in the north wall, one in the east wall, and two in the south wall, with 6¼"-wide two-fascia architraves (Type T-35). The reveals of the south openings are faced with recessed paneling. The door in the southwest opening has been removed. A sixth door opening, in the west wall, was a window prior to circa 1850 and has an architrave with the same profile as the other openings.

No. 2021: Original pair of 1¼" thick stile-and-rail doors. Each leaf has two glazed panels above a raised panel (Type D-21); the glazing is a later insertion. Hardware: Pair of original 5" iron butt hinges at each leaf, and a circa 1929 5¼"-high brass or bronze mortise lock stamped "P 11," with an internal bolt, on the north leaf. The south leaf has a recent 4½" bronze slide bolt on the bottom rail and an original 9¼"-high iron slide bolt on the top rail. A 4"-wide bronze slide bolt secures both leaves. The south leaf originally had a 5"-high mortise lock.

No. 2022: A circa 1850 1½" thick stile-and-rail door with four recessed panels (Type D-26). Hardware: Pair of original 3" butt hinges and a circa 1929 5¼"-high brass or bronze mortise lock stamped "P 10." Each side has a brass or bronze 7" escutcheon plate and 2¼" diameter knob. The door originally had a small (3¼" by 4") box lock mounted on the east face.

*Lighting:* There is no artificial lighting. Switch with plastic switch plate in north wall, west of door 2031.

*Plumbing:* A 1' 3" by 8" chase was removed from the northwest corner of the hall in 1992, revealing a copper water line and a galvanized-steel water line.

*Other Features:* Four 7' 8½"-tall plywood closets, each with two sliding flush doors, placed here after the mid-twentieth century. The two east closets are

## PAVILION V



*Room 203 Study*

1' 7" deep by 6' 0" wide, and the two west closets are 1' 7" deep by 4' 0" wide. A 1½"-high cymatium trims the top of each closet.

*Paint Investigation:* Originally, the trim was painted yellowish white (2.5Y9/2), and the vertical face of the baseboard was finished with a reddish-brown (10R3/2) color. The doors were grained to imitate mahogany. Evidence on the plaster wall surfaces revealed that a whitewash was used initially; this was followed by wallpaper.

### ROOM 203 STUDY

Most recently used as a study, this room was originally a bedchamber, one of two such rooms on the second floor of the original pavilion.

The room includes three windows that extend to the floor, a single door in the south wall, and a corner fireplace. This fireplace may have had a cast-iron Franklin stove.

The Jefferson floor plan illustrates the room much as it is today, except for two differences. There is no

triangular chimney mass in the southwest corner; instead, Jefferson shows a Franklin stove set in the corner. The original floor plan also includes a doorway in the west wall. Breaks in the baseboard indicate that this door may have existed. Pavilion I, which has a plan very similar to this pavilion, has a door that joins the two chambers in the same position.

*Floor:* Original random-width tongue-and-groove boards, running north-south, stained and varnished.

*Ceiling:* Original plaster, painted, approximately 10' 8" above the floor.

*Walls:* The east and north walls are original plaster on brick masonry. The west and south walls are original plaster on wood lath.

*Baseboard:* Original 8¼"-high baseboard, including a 6"-high splashboard with a 2¼"-high molded top (Type B-2). A break in the north end of the west baseboard indicates the location of a former door.

*Cornice:* Original 1' 7"-high wood entablature with a two-fascia architrave, a plain frieze, and an unornamented cornice (Type C-2).

## ARCHITECTURAL DESCRIPTION



*Room 203 Study*

**Doors:** One original doorway in the south wall with a 6½" wide two-fascia architrave (Type T-35).

No. 2031: Original 1½" thick stile-and-rail door with six raised panels (Type D-22). Hardware: Original pair of 5" iron butt hinges and a circa 1929 5¼"-high brass or bronze mortise lock stamped "P 10." Each side has a brass or bronze 7" escutcheon plate and 2¼" diameter knob. The door originally had a 5"-high mortise lock and 2¼" diameter roses with knobs.

The Jefferson floor plan and physical evidence at the baseboard indicate that originally there may have been a doorway in the west wall. The six-panel door most recently used as the door to Room 101B may be the door from this position.

**Windows:** Two original windows in the east wall and one original window in the north wall, with splayed, paneled reveals and paneled heads. Each window is framed with a 6½" wide two-fascia architrave (Type T-36) terminating at splashboard-height plinths. The reveals are divided at the level of the meeting rails, and each portion has a tall, thin, rec-

tangular panel with a small, square panel above. Each window has original 6/6 double rope-hung sash, with 12" by 18" panes, ⅜" muntins, and a twentieth-century sweep thumb latch on the meeting rails. The bottom sash of the north window has been raised approximately 9" above the floor to align with the roof ridge above the dormitory rooms immediately north of the pavilion.

**Fireplace:** The original chimney breast extends diagonally across the southwest corner of the room; it is approximately 4' 9" wide. The surround and firebox opening have been plastered over; the plaster is painted black. The original wood surround consists of a 6½" wide two-fascia architrave. A 1½" thick mantel shelf sits directly above the architrave. This shelf was installed in the twentieth century. The area of the original hearth has been filled in with narrow tongue-and-groove flooring.

**Heating:** One four-column, 11-section, cast-iron hot-water radiator is located between the two east windows. The radiator is marked "American Radiator" and "Peerless."

## PAVILION V



*Room 204 Bedroom*

*Lighting:* There is no artificial lighting in the room. A circular metal plate on the south wall marks the location of a previous wall fixture. Other electrical elements include a switch with plastic switch plate east of door 2031, three duplex receptacles in the baseboard, two duplex receptacles in the base of the shelves, and a junction box with a duplex receptacle inside the shelves. Rigid metal conduit runs from the box to a receptacle in Room 204.

*Other Features:* Twentieth-century, built-in wood bookcases have been installed along the north wall. Each unit includes seven adjustable shelves and a shelf resting on the base (on which electrical outlets are mounted), approximately 9¼" above the floor.

*Paint Investigation:* The wood trim, including the fireplace surround, was originally covered with yellowish white (2.5Y9/2) paint. The recent mantel shelf is covered with two layers of white paint. The vertical face of the baseboard was painted with a red-brown (10R3/2) color. The paneled door was originally grained to imitate mahogany.

Evidence on the plaster wall surfaces indicates

that wallpaper was the earliest finish, followed by the application of a beige (10YR8/2) paint.

### ROOM 204 BEDROOM

This room has maintained its function as one of the two original second floor bedchambers. Natural light enters the room from four windows that extend to the floor. The door in the south wall opens to the central hallway. Evidence indicates that there may have been a doorway in the east wall. The corner fireplace is the most important feature in the room. The fireplace opening may have had a cast-iron Franklin stove.

The current floor plan generally follows the plan drawn by Jefferson; however, the Jefferson plan does not show a triangular chimney mass in the southeast corner, but instead a free-standing Franklin stove is positioned there.

*Floor:* Original, random-width (3¼" to 5½") tongue-and-groove boards, running north-south, stained and varnished.

## ARCHITECTURAL DESCRIPTION

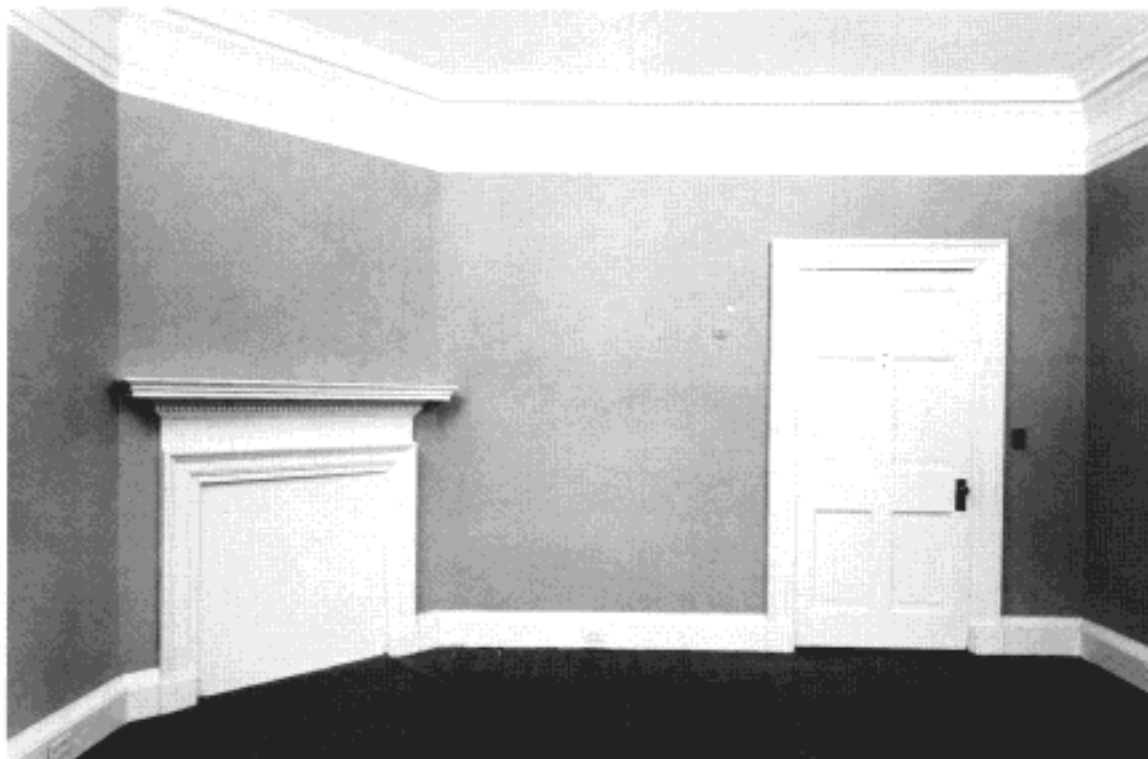

*Room 204 Bedroom*

**Ceiling:** Original plaster, painted, approximately 10' 8" above the floor.

**Walls:** The west and north walls are original plaster on brick masonry. The south and east walls are original plaster on wood lath. All of the surfaces are painted.

**Baseboard:** Original 8 $\frac{1}{2}$ "-high baseboard, including a 6"-high splashboard with a 2 $\frac{1}{2}$ "-high molded top (Type B-2).

**Cornice:** Original 1' 7 $\frac{1}{2}$ "-high wood entablature with a two-fascia architrave, a plain frieze, and an unornamented cornice (Type C-2).

**Doors:** One original doorway in the south wall with a 6 $\frac{1}{4}$ "-wide two-fascia architrave (Type T-35).

No. 2041: Original 1 $\frac{3}{8}$ " thick stile-and-rail door with six raised panels (Type D-22). Hardware: Pair of original 5" iron butt hinges and a circa 1929 5 $\frac{1}{2}$ "-high brass or bronze mortise lock stamped "P 10." Each side has a brass or bronze 7" escutcheon plate and 2 $\frac{1}{4}$ " diameter knob. The door originally had a 5"-high mortise lock.

A break in the baseboard on the east wall indi-

cates that there may have been a doorway in the east wall, as shown on the Jefferson floor plan.

**Windows:** Two original windows in the west wall and two original windows in the north wall, with splayed, paneled reveals and paneled heads. Each window is framed with a 6 $\frac{1}{2}$ "-wide two-fascia architrave (Type T-36) terminating at splashboard-height plinths. The reveals are divided at the level of the meeting rails and each portion has a tall, thin rectangular panel with a small square panel above. Each window has original 6/6 double rope-hung sash, with 12" by 18" panes,  $\frac{3}{16}$ " muntins, and a twentieth-century sweep thumb latch on the meeting rails. The section of thumb latch on the upper sash of the northwest window is missing. All of the brass-faced sash pulleys are original.

**Fireplace:** The original chimney breast extends diagonally across the southeast corner of the room and is approximately 5' 4" wide. The surround and firebox opening have been plastered over; the plaster is painted white. The original wood surround consists of a 6 $\frac{1}{2}$ "-wide two-fascia architrave. Above



## PAVILION V

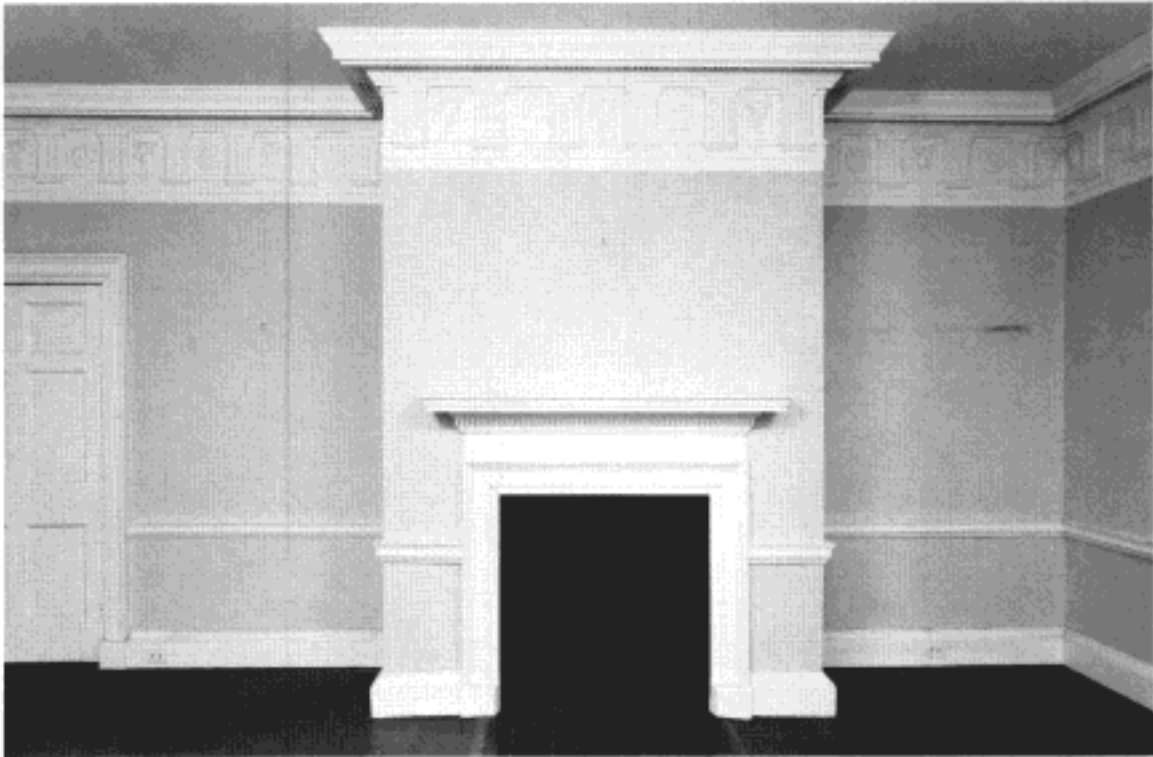

*Room 205 Master bedroom*

the architrave is a 5½" plain frieze and a 7" denticulated cornice supporting a mantel shelf. The hearth is laid with 2¼" by 8" bricks dating to the twentieth century.

*Heating:* One three-column, 18-section, cast-iron hot-water radiator is located between the two west windows. The radiator is marked "American Radiator" and "Peerless."

*Lighting:* There is no artificial lighting in the room. A circular metal plate on the south wall marks the location of a wall fixture. Other electrical elements include a switch with plastic switch plate west of door 2041 and five duplex receptacles in the baseboard. A junction box with a grounded duplex receptacle is mounted to the north wall near the northwest window. Rigid metal conduit runs from this box east to a similar outlet in Room 203.

*Paint Investigation:* The wood trim, including the mantel, was originally finished with yellowish white (2.5Y9/2) paint. The second finish on the mantel was a glossy black paint, typical of mantels in the 1820s and 1830s. The vertical face of the baseboard

and the plinth blocks were originally finished with a red-brown (10R3/2). The same color was used on the top surface of the mantel shelf.

The paneled door was grained to imitate mahogany.

Evidence on the plaster walls indicates that wallpaper was the original finish there followed by a cream-beige (10YR9/2) paint.

### ROOM 205 MASTER BEDROOM (ORIGINAL PARLOR)

This large elegant room originally served as the private parlor of the professor who occupied the pavilion. The architectural detailing used here is the finest found in any of the original rooms. In general, the appearance of the room is very much like that of the corresponding second floor space in Pavilion I. Originally the room received natural light from three windows, but two windows were converted into doorways when the rear addition was enlarged in the early twentieth century. The

## ARCHITECTURAL DESCRIPTION



*Room 205 Master bedroom*

two original doors open to the stair hall and the central hall.

The decorated entablature and the elegant fireplace are the most prominent features in the room.

The room retains all of the elements shown on Jefferson's original second floor plan except that the two windows in the west wall have been replaced with doors; and it appears that a cast-iron Franklin stove was never installed. A full fireplace was constructed as part of the original building.

*Floor:* Original random-width tongue-and-groove boards, running north-south, stained and varnished.

*Ceiling:* Original plaster, painted, approximately 10' 8½" above floor.

*Walls:* The north, south, and west walls are original plaster on brick masonry. The east wall is original plaster on wood lath. The west wall was originally an exterior wall. Additions were constructed beyond the west wall circa 1850 and circa 1903/1929.

*Baseboard:* Original 8¼"-high baseboard, including a 6"-high splashboard and a 2¼" molded top

(Type B-2).

*Chair Rail:* Original 4"-high wood rail (Type T-42).

*Cornice:* Original 1' 11"-high Doric entablature with a single-fascia architrave, a frieze with triglyphs and metopes ornamented alternately with bucrania and rosettes made of a terra-cotta composition, and a cornice. Several of the terra-cotta rosettes are missing. The cornice soffit is ornamented with mutules over the triglyphs lozenge-shaped geometric ornaments (flush with the mutules) of terra cotta over the metopes.

*Doors:* One original doorway in the north wall and one original doorway in the east wall, each with a 6¼"-wide two-fascia architrave (Type T-37). The north opening has a paneled reveal. Twentieth-century doors have been installed in the two original window openings in the west wall. The openings are framed with original 6¼"-wide two-fascia architraves (Type T-37) terminating at splashboard-height plinths. The reveals are divided at the level of the meeting rails and each portion has a tall,

## PAVILION V

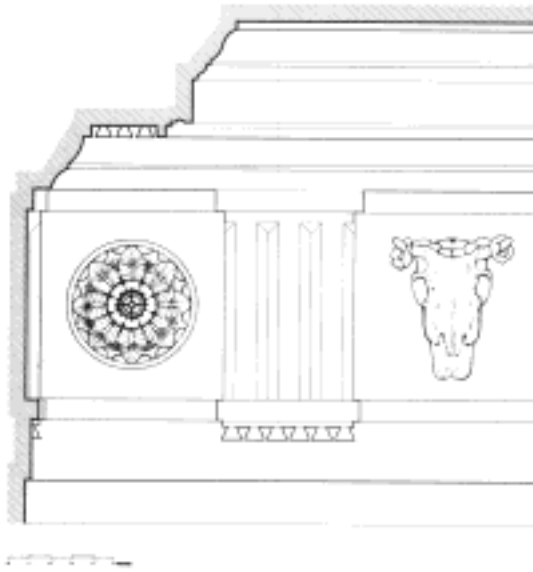

*Detail of cornice, Room 205*

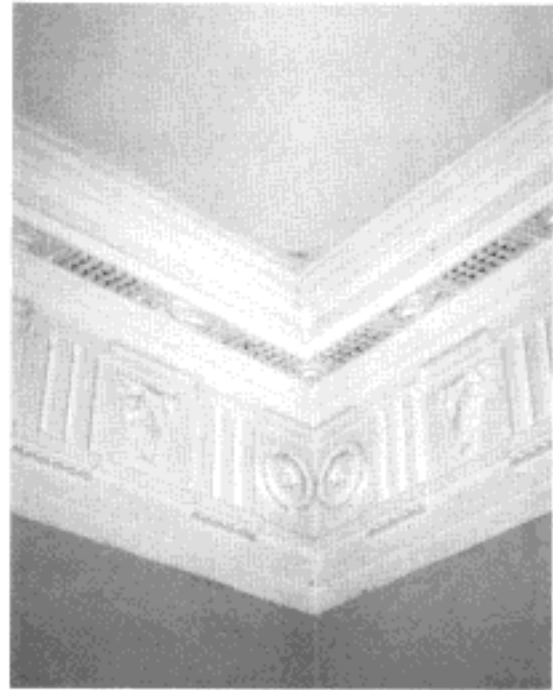

*Cornice, Room 205*

thin, rectangular panel with a small, square panel above.

No. 2051: Original  $1\frac{3}{8}$ " thick stile-and-rail door with six raised panels (Type D-22). Hardware: Original pair of 5" iron butt hinges and a circa 1929  $5\frac{1}{4}$ "-high brass or bronze mortise lock stamped "P 10." Each side has a brass or bronze 7" escutcheon plate and  $2\frac{1}{4}$ " diameter knob. The door retains evidence for a 5" to 6"-high mortise lock and possibly a box lock that may have been an earlier temporary fitting.

No. 2052: Original  $1\frac{3}{8}$ " thick stile-and-rail door with six raised panels (Type D-22). Hardware: Original pair of 5" iron butt hinges and a circa 1929  $5\frac{1}{4}$ "-high brass or bronze mortise lock stamped "P 10." Each side has a brass or bronze 7" escutcheon plate and  $2\frac{1}{4}$ " diameter knob. The door retains evidence of a 5"-high mortise lock as well as of a  $4\frac{1}{2}$ " by 7" box lock. The box lock may have been used temporarily prior to the installation of the mortise lock.

No. 2053: Twentieth-century pair of  $1\frac{3}{8}$ " thick stile-and-rail doors with two raised panels in each leaf (Type D-23). Hardware: Pair of 3" hinges at each leaf and a  $5\frac{1}{4}$ "-high brass or bronze mortise

lock stamped "P 10" in the south leaf. Each side of the south leaf has a brass or bronze 7" escutcheon plate and  $2\frac{1}{4}$ " diameter knob. The north leaf has a  $4\frac{1}{2}$ "-high brass or bronze slide bolt on the bottom rail and a 5"-high iron slide bolt on the top rail. These doors and their hardware may date to circa 1929.

No. 2054: Twentieth-century pair of  $1\frac{3}{8}$ " thick stile-and-rail glazed doors (Type D-25). Each leaf has twelve lights, with  $5\frac{1}{2}$ " by  $8\frac{1}{2}$ " panes and  $\frac{1}{4}$ " muntins. Hardware: Pair of 3" hinges at each leaf and a  $5\frac{1}{4}$ "-high brass or bronze mortise lock stamped "P 10" in the south leaf. Each side of the south leaf has a brass or bronze 7" escutcheon plate and  $2\frac{1}{4}$ " diameter knob. The north leaf has a 5"-high iron slide-bolt surface mounted to the top and bottom rails. These doors and their hardware may date to circa 1929.

*Windows:* One original window in the south wall, with splayed, paneled reveals and paneled head. The window is framed with a  $6\frac{1}{4}$ "-wide two-fascia architrave (Type T-38) terminating at splashboard-height plinths. The reveals are divided at the level of the meeting rails, and each portion has a tall,

## ARCHITECTURAL DESCRIPTION

thin, rectangular panel with a small square panel above. The window has original 6/6 double rope-hung sash, with 12" by 18" panes and  $\frac{9}{16}$ " muntins. Hardware includes a twentieth-century sweep thumb latch on the meeting rails. The brass-faced sash pulleys are original.

The two door openings in the west wall were originally windows that matched the extant window in the south wall. The openings were converted into doorways in the twentieth century.

*Fireplace:* The original 7' 1½"-wide chimney breast projects 2' 2½" from the north wall. The sides and floor of the firebox are constructed of 4¼" by 9" bricks, marked "Penn," while the back of the firebox is constructed of 2¾" by 8¾" bricks. The entire firebox and brick surround are painted black. The surround is bordered by a 7"-wide two-fascia wood architrave below a 4¾" plain frieze and a 7¼" denticulated cornice supporting a mantel shelf. The wood mantel is original. There is a brick hearth projecting 2' 1" from the mantelpiece. The bricks are approximately 2¼" wide by 8" long.

*Heating:* A three-column, 18-section cast-iron hot-water radiator is located against the west wall. The radiator is marked "American Radiator" and "Peerless."

*Lighting:* There is no artificial lighting in the room. Electrical elements include a switch with plastic switch plate north of door 2051, a similar switch south of door 2053, and five duplex receptacles in the baseboard. A grounded duplex receptacle in the south wall, to the west of the window, probably serviced a window air conditioning unit.

*Other Features:* A small, square, tapered hole in the architrave of the entablature on the east wall (adjacent to the northeast corner) may indicate the position of a crank for part of a house bell system. There is a small hole in the flooring directly beneath this feature. The former second floor parlor of Pavilion II retains part of an original house bell system.

*Paint Investigation:* The first finish applied to the wood trim, including the elaborate entablature and the mantelpiece, was a yellowish white (2.5Y9/2) paint. The top surface of the chair rail and the vertical face of the baseboard were covered with a red-brown (10R3.2) paint.

The doors were grained to imitate mahogany.

Evidence of wallpaper was found as the original finish on the plaster walls. This was followed by the application of a light beige (2.5Y8.5/4) paint and a medium blue paint.

### ROOM 206 VESTIBULE

As completed circa 1850, the second floor of the rear addition connector or hyphen consisted of a single room that consisted of what is now Room 206, 206A, and 206B. Prior to the extensive enlargement of the hyphen circa 1903/1929, the roof and ceiling height were lower; they were approximately level with the top of the doorway in the west wall.

Access to the space, whose function remains unknown, was from the doorway (originally a window) in the east wall, which opened to the second floor hall of the 1819-23 pavilion. Because of the difference in floor levels between the original pavilion and the hyphen, several steps were needed to descend into this room. At the west end of the room a door opening provided access into the stair hall of the rear addition. The original room may have functioned simply as a convenient connector hallway between the original pavilion and the rear addition or it may have served as a sort of porch.

Evidence in the south wall for a large window opening, perhaps for a tripartite window, indicates that the room received ample natural light. Modifications to the north wall make it impossible to determine if a similar opening was located there.

When the roof was raised circa 1903/1929, a pair of French doors was installed in the north wall. At the same time, or soon after, partitions were inserted and the floor was raised at the east end. Eventually the room was divided into a small vestibule (206) and two bathrooms (206A and 206B), which served the separate front and rear residences.

*Floor:* The narrow, circa 1903/1929, tongue-and-groove flooring extends to the east wall in what is now Bathroom 206B.

*Ceiling:* Circa 1903/1929 plaster on sawn lath, 8' 8" above the floor. The roof and the ceiling were rebuilt circa 1903/1929.

*Walls:* The north, south, and west walls are plaster on brick masonry. The east wall of the vestibule was plaster on sawn wood lath; it was removed in 1992. The north and south masonry walls date to circa 1850. Additional brick above the head height of the door was installed when the roof was raised circa 1903/1929. The east partition was constructed circa 1903/1929 as part of the extensive enlargement of the connector.

The removal of the east partition revealed evidence of an original, wide opening centered in the south wall, approximately 6' 9" wide and 6' 10" high. It may have contained a tripartite sash arrange-

## PAVILION V

ment that extended from the floor to the height of the original, circa 1850 exterior cornice. The opening was closed when the roof was raised and the connector was extended to the south circa 1903/1929.

*Baseboard:* There is a 5¼"-high splashboard with flush bead at top edge (Type B-4) on the west wall and a circa 1903/1929 7¼"-high splashboard, including 1½" molded top and shoe molding (Type B-3) on the north wall.

*Doors:* One circa 1903/1929 door opening in south wall with a 4½"-wide single-fascia architrave (Type T-39). An original, circa 1850 opening in the west wall is framed with a 3"-wide beaded trim (Type T-32); the reveal is faced with wood.

*Lighting:* A lighting fixture is mounted at the approximate center of the ceiling.

*Other Features:* A closet with shelving was constructed at the north end of the space sometime after the circa 1903/1929 remodeling. At a much later date a smaller closet was constructed in the southeast corner of the vestibule.

*Paint Investigation:* The plaster walls of the original room (including spaces 206A and 206B) were covered with wallpaper. A very small fragment of paper was discovered on the north wall surface. The paper had been covered by the later construction of the east partition; this partition was removed in 1992. The room remained papered until the ceiling and roof were raised circa 1903/1929. At that time the plaster was painted a gold/tan (7.5YR8/4) color. The wood trim retains layers of yellowish white (2.5Y9/2) paint.

### ROOM 206A BATHROOM

*Floor:* Narrow tongue-and-groove flooring dating to the twentieth century that replaced the original, circa 1850 flooring. This floor extends into Room 206 and beneath the raised floor of Room 206B.

*Ceiling:* Circa 1903/1929 plaster on sawn lath, 8' 8" above the floor.

*Walls:* The north and south walls are circa 1850 plaster on brick masonry. The east and west walls were removed in 1992. The west partition was plaster on sawn wood lath, circa 1903/1929, and the east partition was plaster on expanded metal lath, circa 1929 or later.

*Baseboard:* 7⅝"-high splashboard with molded top (Type B-3).

*Doors:* Pair of circa 1903/1929 glazed doors in north wall, framed with a 4½"-wide single-fascia ar-

chitrave (Type T-39). The interior faces of the doors are painted pink, and the exterior faces are painted white. A door in the west partition was removed in 1992.

No. 206A1: Pair of circa 1903/1929 1⅜" thick stile-and-rail glazed doors (Type D-29). Each leaf has 21 lights, with 5" by 7½" panes and ¾" muntins. There is a single raised panel below the glazing. Hardware: Each leaf has a pair of 3" butt hinges. The east leaf has a ¾" by 4" box lock marked "Rye Co. USA," porcelain knobs, a metal keyhole escutcheon, an escutcheon and keyhole remaining from a previous latch, and two slide bolts. The west leaf has a keeper marked "1888" and three slide bolts (two at the base and one at the top).

*Windows:* The glazed doors allow natural light to enter this space. The removal of the east and west partitions revealed evidence of an original window opening centered in the south wall, approximately 6' 9" wide and 6' 10" high.

*Heating:* Three-column, five-section ornamented, cast-iron hot-water radiator is located west of door 206A1. There are no manufacturer's marks on the radiator.

*Lighting:* A chrome and glass lighting fixture is mounted to the ceiling near the center of the room.

*Plumbing:* The plumbing fixtures removed from this room in 1992 include one vitreous china toilet from the east wall, marked "Wellworth 11098 7 24 61 3"; one enameled, cast-iron lavatory from the east wall, marked "Kohler USA, 7 24 61, 2701-19x17-17S"; and an enameled, cast-iron bathtub marked "Kohler USA, S16-5 2S, 7 26 61." The manufacturers' dates on these fixtures reveal that they were installed in 1961 or later.

*Other Features:* Before the 1992 renovation there was a two-door cabinet surface mounted to the west wall.

### ROOM 206B BATHROOM

*Floor:* ¾"-wide pine subflooring, running east-west. The floor is approximately 7" below the floor level of the original pavilion. Remnants of grout from a tile floor (removed in 1992) remain on the surface. This floor was constructed above the floor surface in Rooms 206 and 206A circa 1929 or later.

*Ceiling:* Painted plaster, 7' 1" above floor. This surface dates to circa 1903/1929.

*Walls:* The east wall is plaster on original, 1819-23 masonry. This surface was originally part of the rear exterior wall of the pavilion. The north wall is

## ARCHITECTURAL DESCRIPTION

plaster on brick masonry. Part of the plaster has been removed from the south wall, revealing expanded metal lath over roughly finished brick, similar to the brick on the north wall in Room 210. The west wall is plaster on expanded metal lath. Above the bathtub, the west wall is finished with 4¼" white ceramic tiles, set in grout on expanded metal lath.

*Baseboard:* A twentieth-century 6"-high splashboard on north, east, and west walls.

*Doors:* One door in the east wall with a 6"-wide two-fascia architrave surround. This opening was originally the west window opening of the central second-floor hall (Room 202) of the pavilion. It was converted into a doorway when the rear addition was constructed circa 1850.

*Windows:* One twentieth-century window opening in north wall, with a 6"-wide two-fascia architrave surround terminating on a 1" thick sill above a 4¼"-high two-fascia apron. The casement sash opens to the north, hangs from the east jamb on two 3½" butt hinges, and is secured with a small brass latch. The sash has nine 5" by 7½" panes with ⅝" muntins.

*Heating:* One four-column, twelve-section, cast-iron hot-water radiator sits between the two east windows. The radiator is marked "National."

*Lighting:* Electrical elements include wiring for a wall fixture on the east wall and a switch on the east wall.

*Plumbing:* The plumbing fixtures removed from this room in 1992 include one white vitreous china toilet from the west wall, dated "December 1979" on the inside of the tank lid; one white vitreous china lavatory from the east wall, marked "Kohler USA" and "K2006 17 8114 7 1 [?]"; and an enameled, cast-iron bathtub with "11 6805 2-4 6247" marked in chalk.

Supply lines to the lavatory protrude through east wall, and supply lines to the bathtub and shower protrude through the floor. The supply line to the toilet remains in the west wall, and the capped-off waste line remains in the floor.

*Other Features:* Recessed medicine cabinet with mirrored door on east wall. Chrome towel rack on south wall. Chrome shelf brackets on east wall. Ceramic towel rack and soap dish and wood curtain rod in bathtub area. Chrome "Marathon Tissue" toilet paper holder south of toilet.

A 9½"-deep by 1' 4"-wide by 4' 4"-high wood cabinet was removed from the north wall in 1992. The cabinet was supported by carved wood brackets and had a door hung on butterfly hinges opening onto four shelves.

### ROOM 207 STORAGE

This room and the adjoining bathroom (208) were created circa 1903/1929 when the roof was raised above the circa 1850 connector. The original function of the room is unknown; most recently, it served as a store room.

*Floor:* Original, circa 1903/1929 tongue-and-groove boards, running east-west, stained and varnished.

*Ceiling:* Circa 1903/1929, painted plaster on sawn wood lath, 8' 9" above floor.

*Walls:* The north and west walls are circa 1903/1929 plaster on circa 1850 brick masonry; the east wall is circa 1903/1929 plaster on sawn lath. The south wall is plaster on circa 1903 brick masonry.

*Baseboard:* Original, circa 1903/1929, 7¾"-high splashboard, including 1½" molded top and shoe molding (Type B-3).

*Doors:* One circa 1903/1929 doorway in north wall with a 4½"-wide single-fascia architrave surround (Type T-39).

No. 2071: Circa 1903/1929 1¼" thick stile-and-rail door with four raised panels (Type D-27). Hardware: Original pair of 3" butt hinges, a 3¼" by 3¾" iron box lock with brass knobs, a small metal keyhole escutcheon, and two brass hooks.

*Windows:* One original, circa 1903/1929 window in south wall with 6"-wide two-fascia architrave (Type T-26) terminating on a 1¼" thick bullnosed sill above a 3"-high apron. The apron is finished with a flush bead at the bottom edge. The opening has 6/6 double rope-hung wood sash with 10" by 14" panes, ⅝" muntins, and a sweep thumb latch on the meeting rails. The sill is covered with marbled vinyl film.

*Heating:* Three-column, seven-section, cast-iron hot-water radiator located immediately east of the window. There are no manufacturer's marks on the radiator.

*Lighting:* There is a box lighting fixture mounted to the ceiling near the center of the room. Other electrical elements include a switch and duplex receptacle in the north wall and a duplex receptacle in the baseboard of the pipe chase.

*Plumbing:* A 1' 4"-wide pipe chase in the southeast corner of room contains a waste line and a domestic water line. This chase is contemporary with the construction of the room.

*Other Features:* Television coaxial cable extends through a hole in the window sill.

## PAVILION V

### ROOM 208 BATHROOM

This room was created when the circa 1850 connector was enlarged, circa 1903/1929. At that time rooms were added to the south side of the connector at the basement, first-floor, and second-floor levels. This room has probably always functioned as a bathroom. The plumbing vent pipe in the southeast corner of the adjoining room (207) is an original feature of the circa 1903/1929 addition. Although there is another floor surface beneath the existing bathroom floor, evidence reveals that the lower surface was never used. None of the wall surfaces below the existing bathroom floor has evidence for any form of finish.

All existing bathroom fixtures were installed after the middle of the twentieth century.

*Floor:* Original, circa 1903/1929, 3¼"-wide tongue-and-groove flooring, running east/west. Remnants of grout from a tile floor, recently removed, remain on the floorboards. This floor is approximately 7" below the floor level of the original pavilion. The bathroom floor is constructed above a tongue-and-groove floor that is at the same level as the floor in Room 207. Physical evidence (lack of plaster on the brick wall surfaces and on the west stud wall below the level of the current floor) indicates that the lower floor was never used.

*Ceiling:* Painted plaster, 7' 1" above floor. The circa 1903/1929 wood lath and plaster ceiling is covered by a later surface of plaster on expanded metal lath.

*Walls:* The east wall is circa 1903/1929 plaster on original 1819-23 brick masonry. Before this room was constructed, this would have been the rear exterior wall of the original pavilion. The north and south walls are plaster on masonry. The north brick surface was the exterior (south) wall of the circa 1850 connector. The upper eight brick courses were exposed when the connector was enlarged and the roof and cornice were raised circa 1903/1929. The original circa 1850 window opening of the connector can be seen in this wall; it has been crudely filled with brick (some reused brick with white paint). The west wall is plaster on expanded metal lath. The original circa 1903/1929 plaster was removed when the metal lath was installed. A plaster-on-lath wing wall was constructed when the bathroom was installed. The walls above the bathtub are faced with 4¼" square white ceramic tiles.

*Baseboard:* 5½"-high splashboard. The splash-

board does not extend across the bathroom alcove, nor does it run beneath the door threshold. A quarter-round shoe molding runs along the fascia board beneath the threshold.

*Doors:* One doorway in the original pavilion window opening in the east wall, with a 6¼"-wide two-fascia architrave surround.

*Windows:* One circa 1903/1929 window opening in the south wall, with a 6"-wide two-fascia architrave terminating on a 1" thick bullnosed sill, approximately 7" above the floor. The original, circa 1903/1929 6/6 double rope-hung window sash have 10" by 14" panes, ⅝" muntins, and a sweep thumb latch on the meeting rails.

*Heating:* One four-column, 21-section, cast-iron hot-water radiator is located against the north wall. The radiator is marked "National."

*Lighting:* Wiring remains in the ceiling for a light fixture (removed in 1992).

*Plumbing:* The plumbing fixtures removed from this room in 1992 include one white vitreous china toilet from the west wall, dated "December 1979" on the inside of the tank lid; one enameled, cast-iron lavatory from the east wall, marked "Kohler USA, 2700, 22 x 10-4-9" and "2 1 52 D"; and an enameled, cast-iron bathtub with "3 6288 2-1 6305" marked in chalk.

There are supply pipes and a waste pipe in the east wall, a water-supply pipe to the toilet in the west wall, a waste line in the west end of the floor, and hot-and-cold-water lines in the floor at the former location of the bathtub.

*Other Features:* Recessed medicine cabinet with mirrored door in east wall. Chrome soap dish on east wall. Chrome towel racks on south wall and on south face of the bathtub wing wall.

A 9¼" deep by 3' 6" wide by 4' 4" high wood cabinet was removed from the east end of the north wall in 1992. The cabinet had a pair of doors hung on butterfly hinges.

### ROOM 209 REAR STAIR HALL

This hall duplicates in plan the first floor stair hall (107) directly below. Evidence of the original, circa 1850 finishes survives, but some changes and additions were made in the nineteenth and twentieth centuries.

The earliest modification was the creation of a doorway in the north wall. This doorway provided direct access to Room 210.

Circa 1903/1929, when the connector was en-

## ARCHITECTURAL DESCRIPTION

larged, the small horizontal window opening was inserted in the south wall of the stair landing. An earlier window was possibly positioned in the east wall, but this would have been closed over when the connector was expanded to the south.

Although the paint layering on the trim of the door opening in the east wall has been disturbed and is difficult to analyze, it seems to indicate that opening was created or possibly enlarged when the connector was modified, circa 1903/1929.

*Floor:* Original, circa 1850 tongue-and-groove boards, running north-south, stained and varnished.

*Ceiling:* Painted plaster on metal lath, 8' 8" above the floor. This twentieth-century surface replaces the original plaster on split-wood lath.

*Walls:* The east, west, and south walls are of circa 1850 plaster on brick masonry. The north partition is of original plaster on wood lath.

*Baseboard:* Original 5½"-high splashboard with flush bead along the top edge (Type B-4).

*Doors:* Two original doorways in the west wall and one later doorway in the north wall, with 4¾"-wide single-fascia architrave surrounds (Type T-39). One original opening in the east wall with a 3½"-wide beaded surround (Type T-32).

No. 2091: 1½" thick stile-and-rail door with six raised panels (Type D-31). Hardware: Pair of 3" butt hinges and a 3¾" by 3¼" iron box lock with brass or bronze knobs. This door opening is a later, perhaps nineteenth century, insertion in the original wall. The door is original to this opening but does not match the circa 1850 four-panel doors to Rooms 211 and 212. The door was originally hinged to the west jamb so that it would swing into Room 210.

*Windows:* One window in the south wall of the stairwell with a 5"-wide single-fascia architrave surround (Type T-33). The rectangular, decorative pivoting sash has 25 lights, ¾" muntins, and a brass or bronze latch at the top of the sash. The opening and sash were installed circa 1903/1929 when the connector was enlarged. There may have originally (circa 1850) been a window in the east wall to light the stairway.

*Lighting:* There is no artificial lighting in the room. Wiring in the west wall between Doors 2111 and 2121 serviced a wall fixture removed in 1992. Other electrical elements include a double switch in the west wall and a grounded duplex receptacle in the north wall.

*Equipment:* Smoke detector above Door 2091.

*Other Features:* One post-1950 7' 4½"-high ply-

wood closet with two sliding flush doors. The closet is 2' 1" deep by 5' 0" wide. A 1½"-high beveled cornice trims the top of the cabinet.

On the stair landing, there is a shelving unit built across the width of the south wall. The unit has four levels of 7¼" deep shelves and measures 5' 0½" high including a 3" cornice. The unit extends up to the bottom architrave of the decorative, pivoting window. This shelving was installed in the twentieth century.

*Paint Investigation:* The original wood trim (circa 1850) was first finished with yellowish white paint, and it retains later finishes of the yellowish white (2.5Y9/2) paint. The baseboard was originally painted a gray (10YR6/1) color.

The doors were grained to imitate mahogany or oak.

The plaster wall surface retains traces of an original wallpaper. Since the wall surfaces of the second floor stair hall are continuous with those of the first floor stair hall (107), this wallpaper would have been the same paper that covered the walls below.

### ROOM 209A CLOSET

The closet was created in the twentieth century when a partition was constructed at the south end of Room 210. At that time the closet door was made to swing outward into the stair hall. The partition was removed in 1992.

*Floor:* Original, circa 1850 tongue-and-grooved boards, running north-south, stained and varnished.

*Ceiling:* Original plaster on split-wood lath, 8' 8"(±) above floor.

*Walls:* The east and west walls are plaster on circa 1850 brick masonry. The later inserted north wall, which was removed in 1992, was 6" thick and was located 1' 11½" from the south wall. The south partition is of original plaster on wood lath. The doorway in the south wall is a later nineteenth-century insertion.

*Baseboard:* A section of original, circa 1850, baseboard survives on the south wall to the east of the doorway.

*Doors:* One doorway in the south wall with a 4¾"-wide single-fascia architrave surround (Type T-39). This opening was inserted sometime after the original construction of the wall.

*Lighting:* One porcelain utility incandescent fixture on the south wall, operated with a chain pull.



## PAVILION V

### ROOM 210 BATHROOM

In its circa 1850 form, this room could be entered only from bedchamber 211. It may have served as a dressing room for the occupant of that space. In the later nineteenth century, a doorway was inserted in the south wall so that the room could be entered directly from the stair hall. It has not been determined when the room was converted into a bathroom, but the most recent plumbing fixtures were placed here in 1961 or later. At some time in the twentieth century a partition was inserted at the south end of the room, thereby creating a closet (209A).

*Floor:* At the time of this survey (1992), the room was under construction and the floor could not be investigated.

*Ceiling:* Twentieth-century plaster on metal lath, 8' 8" (±) above the floor. The original, circa 1850 surface was plaster on split-wood lath.

*Walls:* The north, east, and west walls are plaster on metal lath on original, circa 1850 brick masonry. A 5" thick wing wall at the north end of the bathtub and a 6" thick partition dividing the bathroom from Closet 209A were removed in 1992. The south wall of the original room is of plaster on wood lath.

*Baseboard:* A 6"-high splashboard with flush bead at top edge.

*Doors:* One original doorway in west wall with 6"-wide two-fascia architrave surround (Type T-26). The door opening in the south wall is believed to be a later nineteenth-century insertion. The door was initially hinged so that it would swing into this room.

No. 2101: Original 1¼" thick stile-and-rail door with four recessed panels (Type D-26). Hardware: Pair of original 3" butt hinges and a 4" by 5" Carpenter-type iron box lock with pair of later brass knobs and an original 1¼" by 1¾" oval keyhole escutcheon. The Carpenter lock is original to this location and represents the lock type originally used on the doors of the circa 1850 addition. It is marked "Improved Rimlock No 60" and includes an eagle motif. The same type of lock survives in the circa 1850 rear addition at Pavilion I.

*Windows:* Original window in north wall with 6"-wide two-fascia architrave surround (Type T-26) terminating on a 1" thick bullnosed sill above a ¾" cavetto molding. The 6/6 double rope-hung sash has 12" by 14" panes and ⅙" to ⅝" muntins.

*Heating:* A three-column, ten-section cast-iron hot-water radiator is located below the window in the north wall. The radiator is marked "American Radiator."

*Lighting:* Electrical elements include a light fixture mounted near the center of the ceiling, a switch on the west wall, and a junction box for a light fixture on the west wall (removed in 1992).

*Plumbing:* The plumbing fixtures removed from this room in 1992 include one vitreous china toilet from the east wall, marked "Wellworth 788 7 21 61 6, K4522"; one enameled, cast-iron lavatory from the west wall, marked "Kohler USA, 7 17 61, 2071-19x17S"; and an enameled, cast-iron bathtub marked "Kohler USA." The supply and waste lines for the bathtub remain in the floor near the east wall.

*Other Features:* Recessed medicine cabinet with mirrored door, marked "Grote," on west wall. Chrome toilet-paper holder on north wall.

### ROOM 211 BEDROOM

This large room has probably always functioned as a bedchamber and is one of four similar large chambers created when Professor Harrison had the rear addition and connector constructed circa 1850. As originally completed, there was a doorway in the south wall that connected this room with the similar adjoining chamber.

This room may have been of some importance since it had a small private room that could be entered only by the doorway in the east wall. At some later time a new doorway was created so that the small room could be entered from the stair hall.

*Floor:* Original, circa 1850 tongue-and-groove boards, running north/south, stained and varnished.

*Ceiling:* Original plaster on wood lath, painted, 8' 8" above floor.

*Walls:* Original plaster on brick masonry. There was originally a door in the south wall.

*Baseboard:* Original 5½"-high splashboard with flush bead along top edge and quarter-round shoe molding (Type B-4). A 3' 4"-wide break occurs in the south baseboard at the location of a previous door opening.

*Doors:* Two original doorways in the east wall with 6"-wide two-fascia architrave surrounds (Type T-26). An original 3' 0" (±) door opening in the south wall, located approximately 3' 6" from the east wall, has been filled in. The trim and door from this opening may be the material that was later used to make the door opening between Rooms 109 and 110.

## ARCHITECTURAL DESCRIPTION



*Room 211 Bedroom*

No. 2111: Original 1 $\frac{1}{4}$ " thick stile-and-rail door with four recessed panels (Type D-26). Hardware: Pair of 3" butt hinges and a later 3 $\frac{1}{2}$ " by 3 $\frac{1}{4}$ " iron box lock with brass knobs and small metal escutcheon. The door was hinged originally to swing from the north jamb. Evidence on the lock rail indicates that there was originally a 4" by 6" box lock, probably a Carpenter-type lock.

*Windows:* Two original window openings, one in the north wall and one in the west wall, framed with 6"-wide two-fascia architraves (Type T-26) terminating on 1 $\frac{3}{4}$ " thick sills. Each opening has original 6/6 double rope-hung sash with 12" by 14" panes,  $\frac{5}{16}$ " muntins, and a sweep thumb latch on the meeting rails.

*Fireplace:* The original brick chimney breast extends diagonally across the southwest corner of the room; it is approximately 6' 2" wide. A plaster surround is painted black and is framed at either end by plain wood pilasters applied to fascias. Above the pilasters, a 10"-high frieze supports a 2 $\frac{1}{2}$ "-high cornice and shelf. An original stone

hearth projects from the chimney breast. The wooden mantle is an original feature of the circa 1850 rear addition.

*Heating:* A four-column, 15-section ornamental, cast-iron hot-water radiator is located below the west window. There are no manufacturer's marks on the radiator.

*Lighting:* There is no artificial lighting in the room. Electrical elements include a switch in the east wall, duplex receptacles in the south wall and north baseboard, and a grounded duplex receptacle in the north wall.

*Other Features:* One post-1950 7' 3"-tall plywood closet with two sliding flush doors. The closet is 2' 1" deep by 4' 2" wide. A 2 $\frac{1}{2}$ " cymatium trims the top of the cabinet.

*Paint Investigation:* The wood trim was first finished with a yellowish white (2.5Y9/2) paint, and the baseboard was covered with a gray (10YR4/1) color. The mantel was finished in a glossy black paint, and the doors were grained, possibly to imitate oak.

## PAVILION V

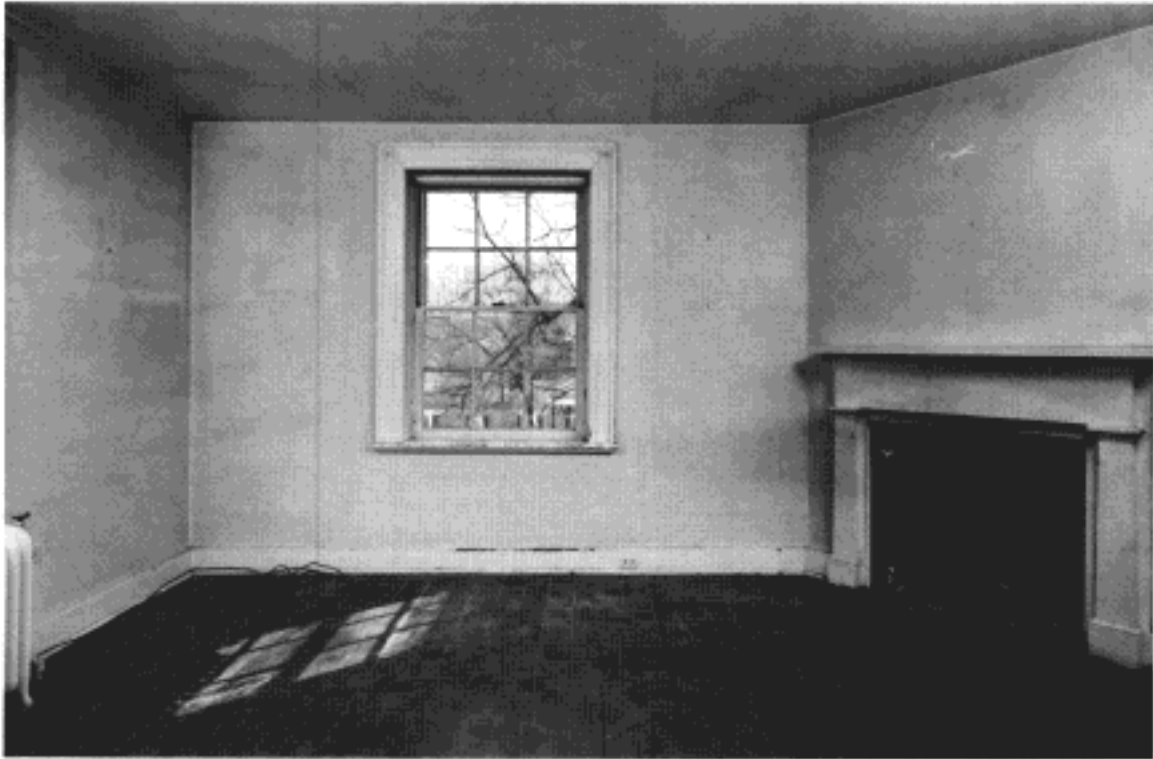

*Room 212 Bedroom*

Minute traces of wallpaper were found on the white plaster wall surfaces.

### ROOM 212 BEDROOM

Since its completion circa 1850 this room has probably always served as a bedchamber. Originally, a doorway in the north wall connected this room to bedchamber 211. The latter room has two windows, while this room has three, two of which face to the south.

*Floor:* Original tongue-and-groove boards, running north/south, stained and varnished.

*Ceiling:* Original plaster on wood lath, painted, 8' 8" above floor.

*Walls:* Original plaster on brick masonry.

*Baseboard:* Original 6"-high splashboard with a flush bead along the top edge and a flattened shoe molding at the bottom edge (Type B-4).

*Doors:* One original doorway in east wall with 6"-wide two-fascia architrave surround (Type T-26). An original 3' 0"( $\pm$ ) door opening in the north wall, lo-

cated approximately 3' 6" from the east wall, has been filled in. The door and trim from this opening may have been used to create the doorway in the wall between Rooms 109 and 110.

*No. 2121:* Original 1 $\frac{1}{4}$ " thick stile-and-rail door with four recessed panels (Type D-26). Hardware: Original pair of 3" butt hinges and an antique 4 $\frac{1}{2}$ " by 6" iron Carpenter box lock with brass or bronze knobs; the lock and its knobs are not original to the door. There is evidence under the lock for a 4"-high by 3 $\frac{1}{4}$ "-wide box lock.

*Windows:* Three original window openings, two in the south wall and one in the west wall, with 6"-wide two-fascia architrave surrounds (Type T-26) terminating on 1 $\frac{1}{4}$ " thick sills. Each opening has original 6/6 double rope-hung sash with 12" by 14" panes,  $\frac{3}{16}$ " muntins, and a recent sweep thumb latch on the meeting rails.

*Fireplace:* The original brick chimney breast extends diagonally across the northwest corner of the room; it is approximately 6' 2" wide. A plaster surround is painted black and is framed at either end

## ARCHITECTURAL DESCRIPTION

by original plain wood pilasters applied to fascias. Above the pilasters a 10"-high frieze supports a 2¾"-high cornice and shelf. The original stone hearth projects from the chimney breast. The wooden mantel dates to the circa 1850 construction of the rear addition.

*Heating:* One three-column, 18-section, cast-iron hot-water radiator is located beneath the southwest window. The radiator is marked "American Radiator" and "Peerless."

*Lighting:* There is no artificial lighting in the room. Electrical elements include a switch in the east wall south of door 2121, two duplex receptacles in the baseboard, and two additional duplex receptacles in the north and south walls.

*Other Features:* A telephone jack is mounted to the east baseboard; station wire extends through the architrave of door 2121 and into the rear stair hall (Room 209).

Television coaxial cable extends through the architrave of the southwest window.

*Paint Investigation:* The original trim was first finished with a yellowish white (2.5Y9/2) paint, and the baseboard was covered with a gray (10YR4/1) finish. The wood mantelpiece was painted with a glossy black.

The door was grained, possibly to imitate oak.

The plaster-wall surfaces were first covered with wallpaper and later painted with a very pale blue (5B9/1) distemper.

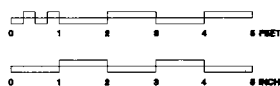
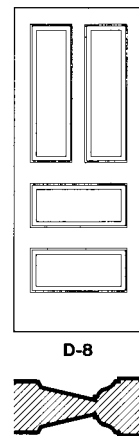
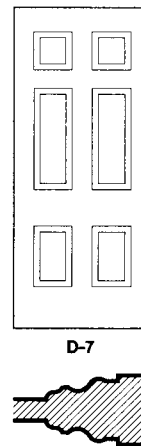
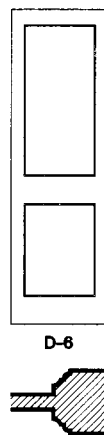
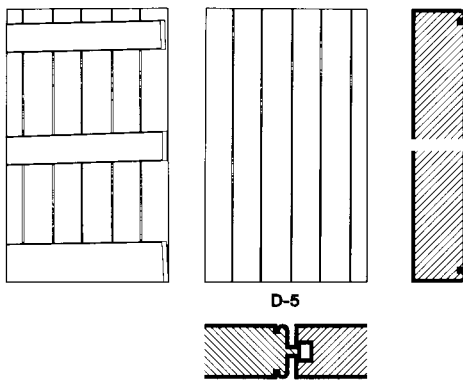
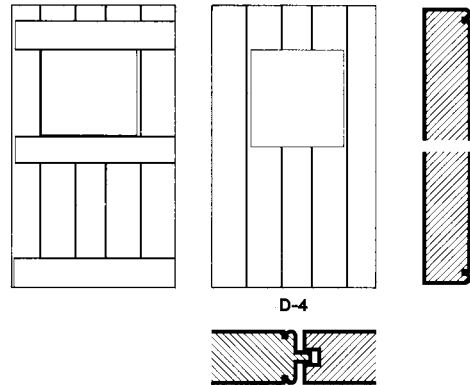
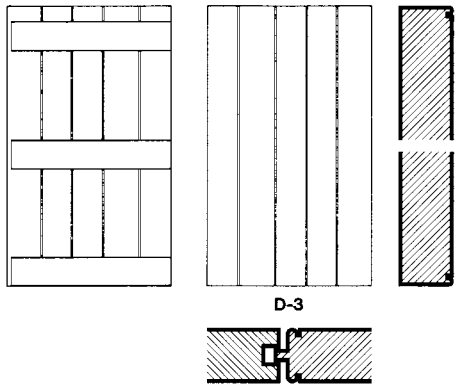
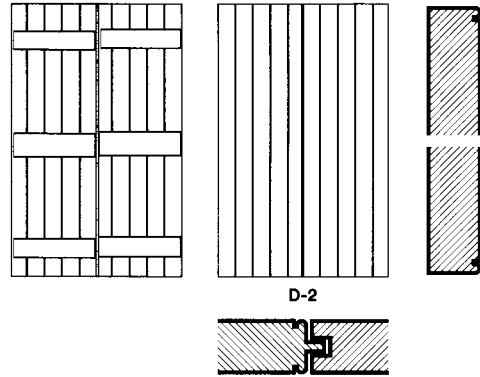
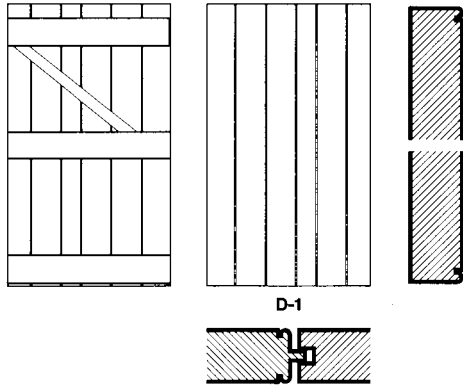

*Elevation and profiles of door types*

## ARCHITECTURAL DESCRIPTION

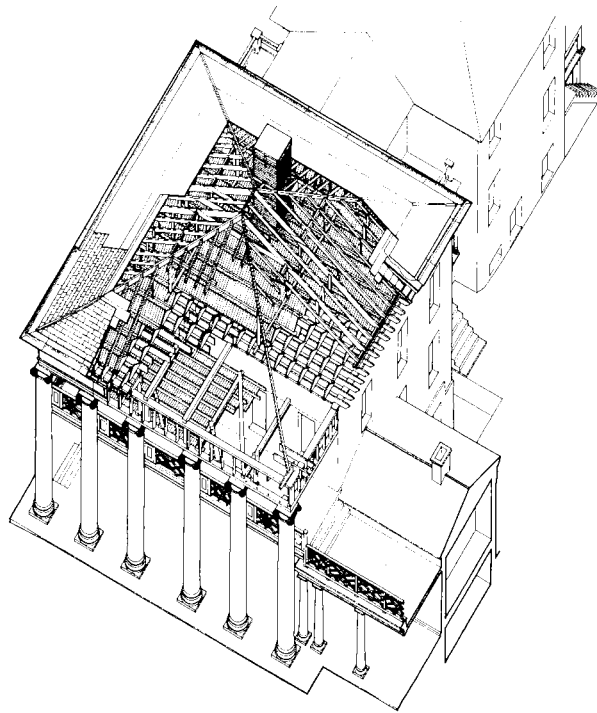

*Axonometric drawing showing the frame construction of Jefferson's ridge-and-furrow roofing system, encapsulated by the 1837 hipped roof. The saw-toothed joists of the original roof were cut away at the perimeter of the building to accommodate the slopes of the new roof.*

### ATTIC

When completed in 1823, the pavilion did not have an accessible attic space between the second floor ceiling and the ridge-and-furrow roof. When the high, hipped roof was installed in 1837, the present attic space was created. The original access hatch, still in place in the second floor hall ceiling, connects the hall directly to the original roof surface and the later attic space; this feature was modified in 1993.

Because the original ridge-and-furrow roof remained in place, it is unlikely that the attic was used for storage. The "floor" was simply too irregular and difficult to walk on.

## PAVILION V

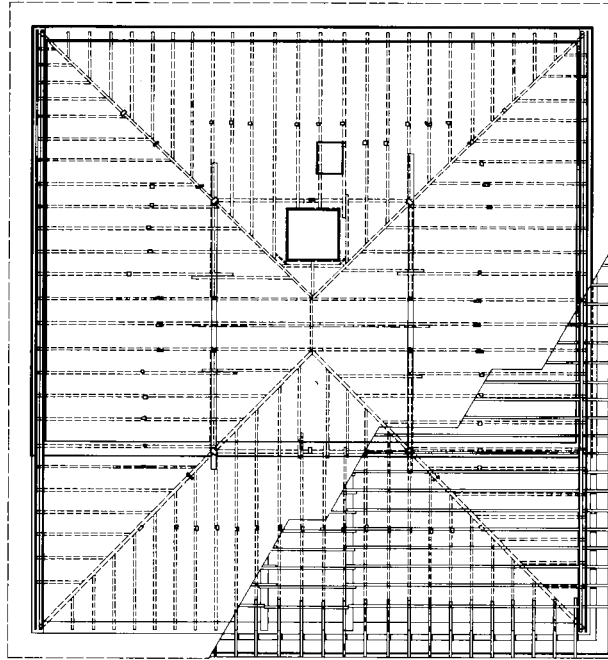

*Roof plan showing the framing (in dashed lines) of the 1837 hipped roof.*

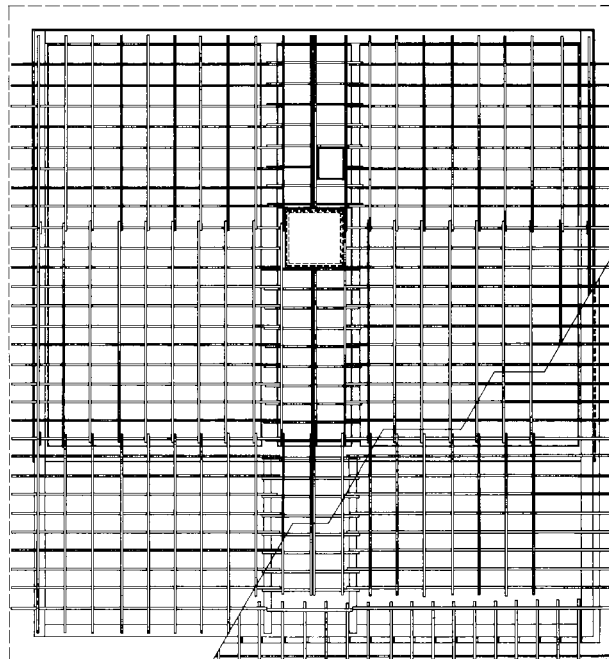

*Roof plan showing the east-west saw-toothed joists of the ridge-and-furrow roofing system bearing on the north-south second floor ceiling joists. The cutaway reveals outrigger framing for the east cornice.*

## ARCHITECTURAL DESCRIPTION

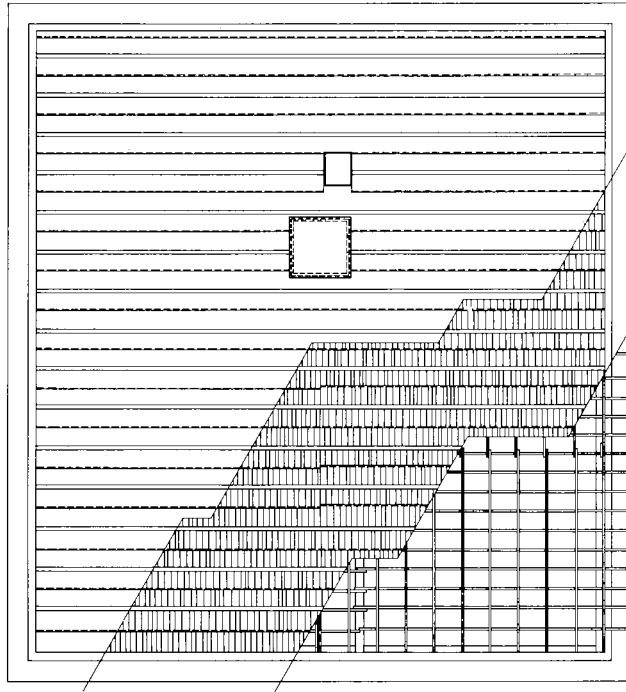

*Roof plan showing the original configuration of the pavilion's ridge-and-furrow roof with a detailed view of the overlapping wood boards and a cutaway revealing the framing below.*

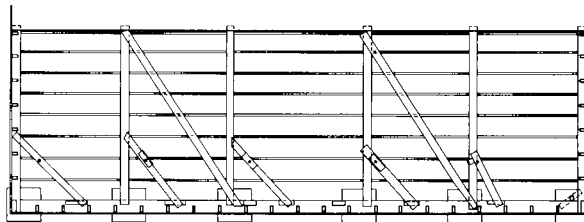

*Plan showing the framing for the east porch ceiling. The short diagonal members support the wrought-iron rods from which the east edge of the porch is suspended.*



## PAVILION V

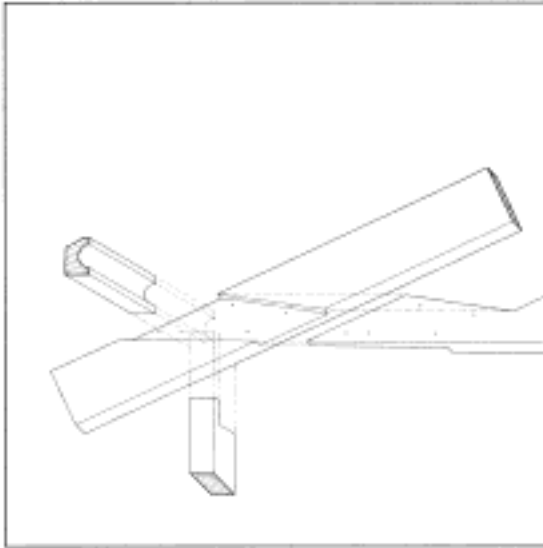

*Exploded view of 1837 roof framing, showing lapped joint of collar tie and rafter with purlin and purlin post. The purlin was fabricated from a section of the pavilion's original wood gutter.*

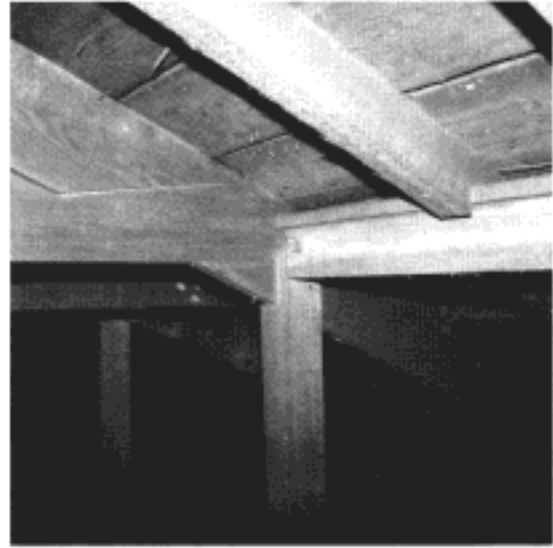

*Original wood gutter reused as purlin in hipped roof*

**Floor:** The floor of the attic is made up of the circa 1819-23 ridge-and-furrow roof. The old roof begins with 2" thick by 9 $\frac{1}{4}$ " to 12"-high ceiling joists running north-south, spaced 1' 2" to 1' 6" apart. Sawtooth roof joists, running east/west (ranging from 5" in the valleys to 12" high at the peaks, set 3' 0" apart), rest on the ceiling joists. Sheathing boards ( $\frac{3}{4}$ " to 1 $\frac{1}{2}$ " thick) are applied to the sawtooth joists to form the base of the roof. At all four sides of the attic the sawtooth joists have been cut off to accommodate the circa 1837 hipped roof members; some of the cut pieces were used in the early twentieth century as supports for electrical knob-and-tube wiring. The valleys of the furrowed roof are finished with tinplate. Two layers of boards (5" to 6" wide by  $\frac{3}{4}$ " thick) are laid north-south along the angles of the roof.

In the area above the east porch, the attic framing is made up of 1 $\frac{1}{2}$ " to 2" thick by 3 $\frac{1}{4}$ " to 5" high joists that support the porch's tongue-and-groove ceiling. The joists run north/south and are notched to tie into 6"- to 8"-wide by 5"-high beams running east-west. Five diagonal braces (running northeast to southwest), set on the beams, support

the wrought iron tie rods of the east porch. No flooring has been laid on the framing that supports the porch ceiling.

**Ceiling:** The attic ceiling is made up of the circa 1837 hipped roof built above the original ridge-and-furrow roof. Wood rafters 2" to 3 $\frac{1}{4}$ " wide by 3 $\frac{1}{4}$ " to 4" high and spaced approx 1' 10" to 2' 0" apart, on center, support 7"- to 14"-wide wood sheathing. Collar ties, 7 $\frac{1}{2}$ " deep, are set approximately 4' 6" above the bottom edge of the sawtooth joists and are fastened to the rafters with half-dovetail mortises and nails.

The structure of the shingled roof can be seen in the attic. Wood sheathing is fastened to the rafters. Along the north and south eaves of the roof, plywood has been fastened to the sheathing; the plywood may bridge the original rainwater diverter of the second roof. Above the sheathing, the roof is covered with asphalt building paper and slate shingles.

**Walls:** Knee walls (approximately 4' 6" high) supporting the hipped roof are constructed of studs spanning a plate resting directly on the ridges of the ridge-and-furrow roof and the rafters (where the collar beams are attached). At some locations, the top plate of the knee wall was constructed with sections of the original, circa 1819-23 wood gutter. The

## ARCHITECTURAL DESCRIPTION



*Original chimney stack extended through 1837 hipped roof*

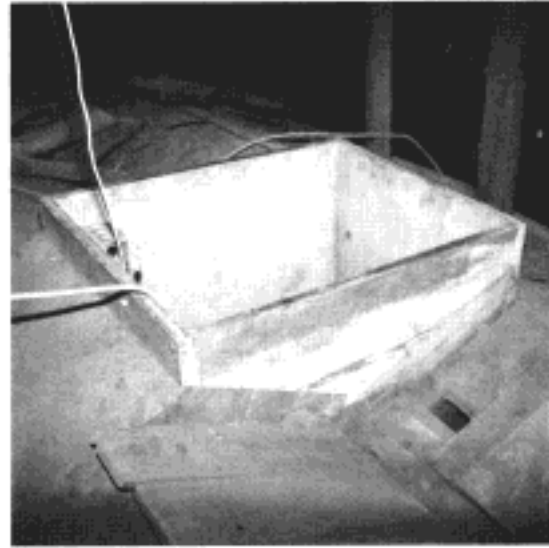

*Jeffersonian roof hatch*

height of the wood gutter ranges from 4 $\frac{3}{8}$ " on its back surface to 5 $\frac{5}{8}$ " at the front; it is 3 $\frac{3}{8}$ " thick with a 1 $\frac{1}{4}$ " diameter hollow.

**Doors:** The original 1819-23 hatch was greatly altered in 1992. The 2' 0" by 2' 5 $\frac{1}{2}$ " hatch was located 2' 4" west of the chimney, and was constructed of 1 $\frac{1}{2}$ " thick tongue-and-groove boards rising 1' 2" above the valleys of the 1819 roof. Original tinsplate flashing, now removed, was nailed to the hatch, and the tinsplate lining of the roof valley was soldered to the flashing. This was a rare example of Jefferson-era soldering.

**Chimney:** The chimney mass (4' 0 $\frac{1}{2}$ " by 4' 1 $\frac{1}{2}$ ") rises from the hall below. The chimney, now enclosed in the attic space, was at one time exposed and features finished mortar joints. The base of the chimney rises nine courses above the top of the joists and then steps back. The primary shaft of the chimney is approximately 4' 0" square, and extends straight for 16 courses. The next course is corbeled out  $\frac{3}{8}$ "; this marks the top of the original (1819-23) chimney. When the new roof was added, the chimney was extended straight up from the corbeled cap.

**Electrical/Lighting:** Remnants of an old knob-and-tube electrical system remain in the attic.

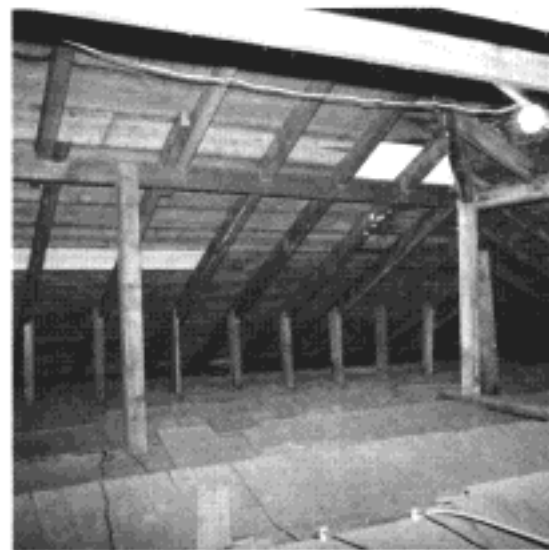

*Jefferson's ridge-and-furrow roof, encapsulated beneath 1837 hipped roof*

## PAVILION V



*Ridge-and-furrow roof clad with wood boards and tinfoil valleys*

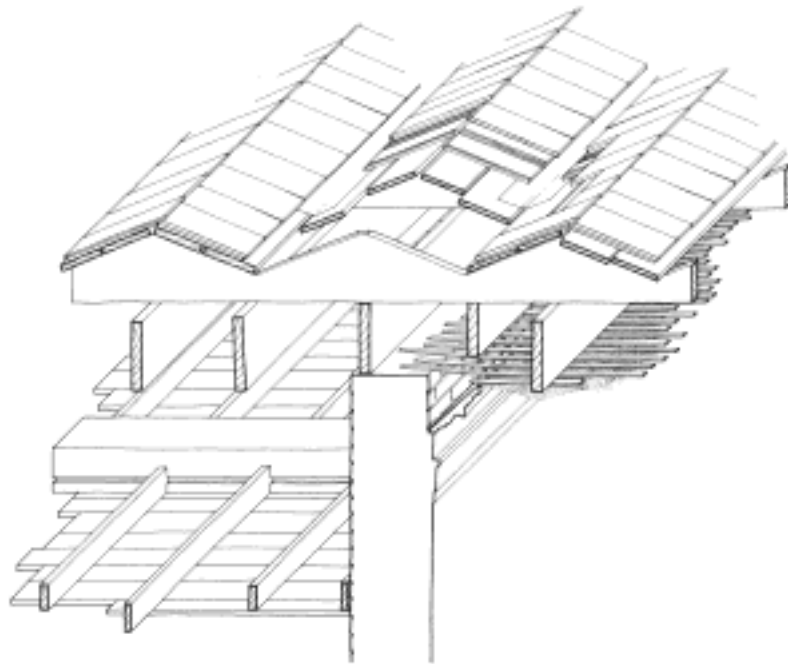

*Axonometric drawing of ridge-and-furrow roofing system above framing of east porch ceiling and second floor study.*

# ARCHITECTURAL DESCRIPTION

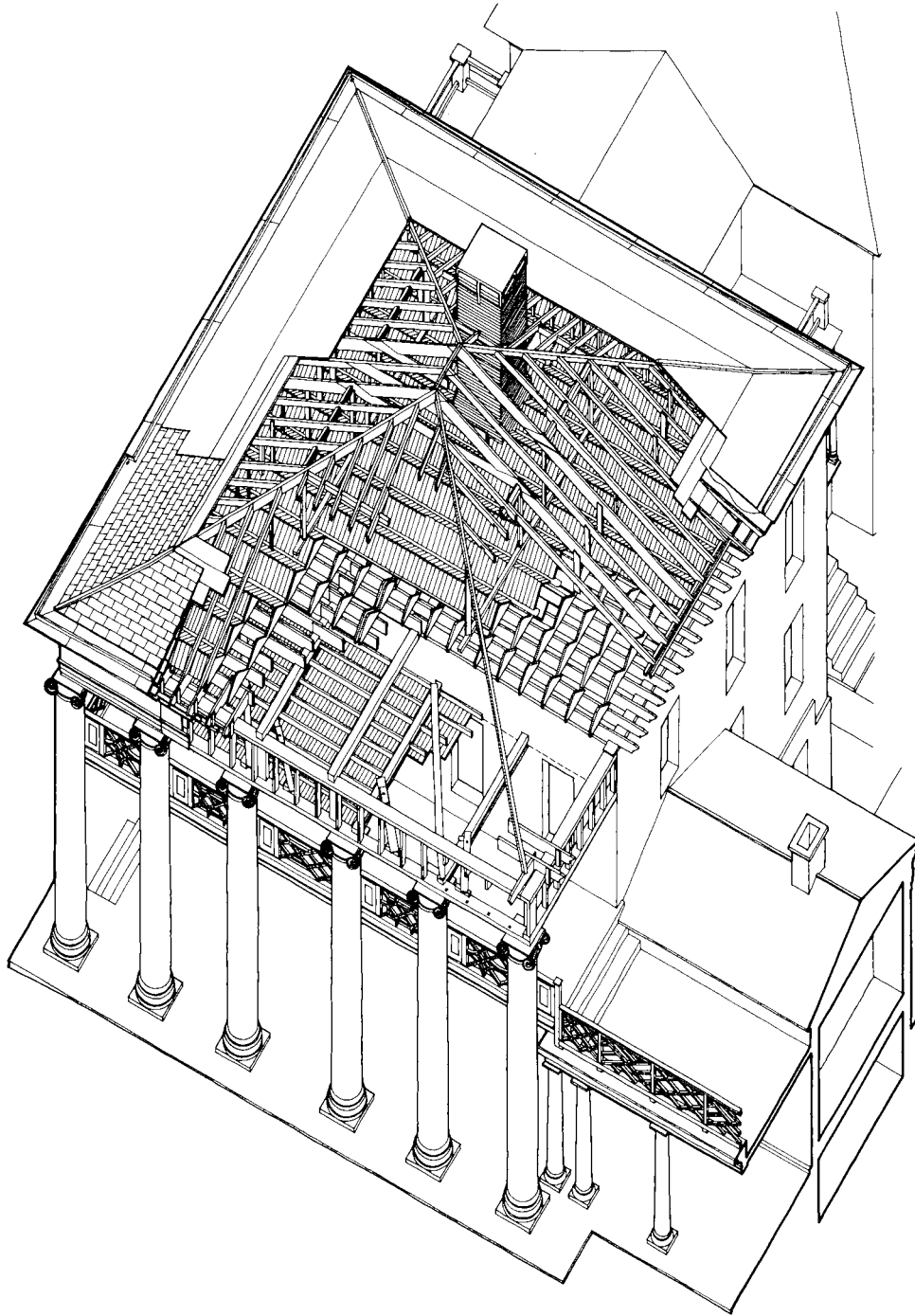

*Axonometric drawing of roof framing*

PAVILION V



*Pavilion V, circa 1930*

## PAVILION V

# PROBLEMS OF REPAIR

Throughout the nineteenth century and the first half of the twentieth century, modifications and additions were made to Pavilion V. The building as it now exists is approximately twice the size of the pavilion that Thomas Jefferson envisioned. Previously, little attention was given to conservation or preservation of the building; expedient alterations characterize much of the work that has been undertaken. Yet in many ways the additive nature of the work has allowed much of the original building fabric to survive. The quality of the original construction has served the building well; it has endured 170 years with relatively few problems.

### EXTERIOR

#### ROOF

The roof structure above the original building envelope was altered in 1837, when a hipped roof was constructed, encapsulating Thomas Jefferson's ridge-and-furrow roof design. Jefferson's intent had been to create the appearance of a flat roof, as viewed from the ground. Similar roof configurations were designed for Pavilion VIII and for the ranges of student rooms linking the hotels and pavilions. Jefferson also had ridge-and-furrow roofs on Monticello and Poplar Forest. In each instance Jefferson's design proved inadequate. By the mid-nineteenth century the flat roofs on the university buildings had been replaced with more traditional gabled and hipped roofs.

When the hipped roof was installed on Pavilion V, the ends of the saw-toothed joists supporting the ridge-and-furrow roof system were cut off to accommodate the angle of the roof slopes. This alteration had little effect on the structure below because the saw-toothed joists were supported by the second-floor ceiling joists, which run in a perpendicular direction. The ends of the saw-toothed joists were left in the attic and later used as supports for knob-and-tube electrical wiring.

## PAVILION V

Pieces of the original wood gutter system were incorporated in the construction of knee-wall framing that supports the rafters of the replacement roof.

Physical evidence suggests that built-in rainwater diverters were incorporated in the design of the hipped roof; these have since been bridged with framing and sheathing. A replacement slate roof was installed in the 1980s, and painted flat-lock terne-coated steel roofing, incorporating a surface-mounted rainwater diverter, has been installed along the eaves of the roof to roughly match previous conditions. The existing downspout configuration is awkward and inefficient; downspouts collect water at the northeast and southeast corners of the pavilion and carry it west, along the entablature, to the rear elevation of the dormitory rooms located to the north of Pavilion V and to the colonnade roof located south of Pavilion V. The paint on the downspouts of the original building is peeling.

The sheet-metal hood attached to the chimney stack of the original building is visually obtrusive; it is awkward in design, and the metal has rusted. The chimney of the rear addition appears to have been repointed with a gray portland cement mortar; the workmanship is of poor quality, and the mortar color does not match the earlier material.

The roofing on the rear addition, connecting hyphen, and west porch consist of painted, standing-seam terne-coated steel. The metal appears to be in relatively good condition; however, some of the construction details are unsophisticated and are inappropriate from the standpoint of both historical accuracy and good modern building practice. Near the center of the west entablature on the original building, the ridge of the gabled roof above the connecting hyphen abuts the upper molding of the architrave; counterflashing obscures nearly all of the architrave along the width of the hyphen roof. The flashing is nailed to the early wood moldings and caulked. Fasteners for supplemental gutter supports along the north and south elevations of the hyphen penetrate the metal roof surface; this detail may contribute to problems with water infiltration. The painted finish on the hung gutters and downspouts of the hyphen and rear addition is peeling. The paint on the cornice of the rear addition is alligatored and water stained. The west porch roof and gutters frequently become covered with leaves from nearby trees, and the galvanized ogee gutter surrounding the porch roof is rusting.

The painted finish on the flat-lock terne roofing at the roof terraces flanking the second floor of the hyphen is peeling, and the metal is rusting. Algae is growing on the metal roofing of the north terrace. Water staining and mildew are visi-

## PROBLEMS OF REPAIR

ble on the cornice molding behind the second floor gutter of the north terrace. The painted woodwork of the balustrades along the terraces is peeling. Much of the wood substrate is exposed, and ferrous staining is visible where the woodwork is nailed together. Elastomeric roofing membrane has been glued to the caps of the balustrade posts as an expedient repair.

### PORTICO AND ENTABLATURE

#### *East Elevation*

1. The Ionic capitals are dirty and require cleaning.
2. There are hairline cracks in the mortar parging on the columns.
3. The mortar joints at either end of the east porch are eroded.
4. The beaded-board ceiling above the east porch does not conceal the wood nailing blocks set in the brickwork of the east elevation. The exposure of the wood blocks, especially at the northeast and southeast corners of the building, may be contributing to their deterioration.
5. Television coaxial cable and twin-lead antenna wire are routed across the brick masonry at the porch level.
6. Exposed, non-grounded electrical receptacles have been recessed in the brick masonry to the north and south of the balcony's central entry.
7. There are holes in the mortar joints flanking the second-floor window blinds; these were apparently used for a previous generation of shutter holdbacks.
8. The paint on the wood treads of the steps leading to the porch entry is alligatored and mildewed.
9. The paint on the wrought-iron support rods at the eastern edge of the porch is alligatored, and the iron is rusting.
10. The wide mortar joints beneath the second floor window sills are cracked.
11. The paint on the underside of the stairway leading from the south end of the porch to the roof of the colonnade is alligatored and peeling.
12. Insects have nested around the base of the prismatic light fixture beneath the porch.

#### *North Elevation*

1. The painted finish on the entablature of the original building is alligatored. The paint adjacent to the downspout penetrations in the cornice is peeling.



## PAVILION V

### *West Elevation*

1. The paint on the entablature of the original building is alligatored and peeling. At the southwest corner of the entablature a large area of wood substrate is exposed.

### *South Elevation*

1. The paint on the cornice of the original building is peeling in the vicinity of the southeast downspout. It appears that wood deterioration has occurred as a result of water infiltration.
2. Television coaxial cable is routed along the entablature and walls of the original building, the hyphen, and the rear addition.

## MASONRY WALLS

### *East Elevation*

1. At the juncture of the pavilion and the dormitory rooms to the north, the brick wall beneath the porch appears to have been discolored by paint chalking from the woodwork above. The brick at this juncture is not interlocked, and mortar is missing from the vertical mortar joint at the first floor level.
2. The brick on the east facade is more exposed at the southern end of the building due to a break in the continuous roofing of the colonnade. An iron oxide wash on the mortar joints in this area has been eroded, and much of the mortar has been leached from the joints. Along the south edge of the facade the brickwork beneath the porch appears to have been discolored by chalking paint above.
3. The brickwork above the southeast window of the living room has been disrupted. Mortar is missing, and the brick has been fractured.
4. On the east elevation of the rear addition, to the north of the connecting hyphen, the mortar joints at the basement and first-floor levels are open and require pointing. At the first-floor level some broken brick is visible. Beneath the porch of the hyphen, efflorescence covers the masonry. At the second-floor level a poorly executed pointing repair was made at the vertical joint between the hyphen and rear addition; mortar has been troweled over the face of the brickwork.
5. On the east elevation of the rear addition to the south of the connecting hyphen, the mortar is eroded and pointing is required. At the second-floor level where the balustrade of the hyphen roof terrace is attached to the rear addition, bricks are broken and missing.

## PROBLEMS OF REPAIR



*South elevation with improper pointing*



*Improper pointing and open mortar joints at the east end of the north elevation*

### *North Elevation*

1. To the west of the student dormitory rooms, pointing repairs have been made between the first-floor and basement windows and between the first- and second-floor window. These repairs have been made with a white cement mortar that has been struck; they do not resemble the early mortar joints that have an applied oxide stain. The iron oxide stain is generally eroded. Other inappropriate pointing campaigns have been carried out; the joints at the basement level of the original building, for instance, are flat and wide, unlike the early joints above.
2. Electrical conduit, coaxial television cable, and telephone wiring have been surface mounted to the face of the brick wall.
3. Paint, algae, and efflorescence are visible on the north elevation of the original building beneath the level of the basement window sills. The algae extend to the head height of the basement windows.

## PAVILION V



*Crazed and peeling paint at the southwest corner of the original entablature*



*Broken brick at the west end of the south roof terrace*

4. At the second-floor roof terrace of the hyphen, algae are growing on the first four courses of brick above the counterflashing.
5. Improper pointing repairs have been made with a dark gray cement mortar along the outside edge of the west door architrave at the porch entry. Above the entry and above the window to the east, pointing repairs have been made with white cement mortar.
6. At the second-floor level of the connecting hyphen, pointing repairs have been made around the window frame with cement mortar. Poor workmanship is displayed in the repairs. Additional pointing repairs have been made along the entire length of the hyphen, between the second floor cornice and the upper architrave of the doorway. It appears that a soft mortar was used; however, the grayish white color and granular texture of the repairs are inappropriate. These repairs were made in an area concealed by a previous cornice. A mortar joint immediately above the door architrave lacks pointing.
7. Beneath the first-floor windows of the rear addition pointing repairs have been made with a grayish-white cement mortar. The joints have been struck, and they differ greatly in appearance from those above.

## PROBLEMS OF REPAIR

8. Near the northwest corner of the pavilion a Canadian hemlock (approximately 18" in diameter) is growing within three feet of the building: the visible shoulder of a tree root is one foot from the sill of the northwest basement window. The root system of the tree is likely to have an adverse impact on the building.

### *West Elevation*

1. At the northwest corner of the original building poorly executed mortar repairs have been made between the basement and first-floor windows. The new white mortar and struck joints contrast sharply with the early buff-colored mortar. The white mortar has been used for a wash above the brick enframing of the basement window and at the line of the watertable. Between the first- and second-floor windows, colored (red) mortar repairs have been made. The early mortar in this area remains in deteriorated condition and requires pointing. There are holes in the mortar joints flanking the middle rails of the open blinds; apparently they were used for a previous generation of shutter holdbacks.

2. Paint, algae, and efflorescence are visible at the northwest corner of the original building beneath the level of the basement window sills.

3. Near the southwest corner of the original building, the vertical mortar joint between the second floor of the connecting hyphen and the original building has been expediently repaired with a hard-setting caulk. The repair was poorly executed.

4. The mortar at the second floor, southwest corner of the original building is deteriorated. The brick at the location of the original shutter holdback, now missing, for the southwest window is broken.

5. Improper pointing repairs have been made across the west elevation of the rear addition with white mortar and struck joints. Efflorescence is visible at the northwest corner, and brick spalling has occurred beneath the porch. To the south of the basement entry damaged brick has been improperly repaired with mortar.

### *South Elevation*

1. On the south elevation of the original building, a stark contrast in mortar color occurs at the sill line of the first-floor windows. Pointing repairs beneath these windows have been made with a white cement mortar that does not match the earlier material in color or finish. Where early mortar remains, the oxide stain applied to the joints is eroded.

## PAVILION V



*Areaway at the northwest corner of the pavilion with surface-mounted wiring, improper pointing, and open joints in the paving*



*Deteriorated mortar and inadequate drainage conditions in the areaway at the northwest corner of the original building*

2. Within the passage between Pavilion V and the dormitory rooms to the south, efflorescence is visible on the south wall of the pavilion up to 30" above grade level.
3. The mortar washes above the projecting brick enframements of the basement windows in the original building are cracked, and portions of the mortar have lost adhesion.
4. The brickwork does not meet the west architrave of the southeast basement window in the original building; repairs attempted with mortar have been unsuccessful.
5. The brick course at grade level between the two southeastern basement windows of the original building has been disrupted by the installation of steel grating and diamond-plate decking. Although the mortar joints in this area have been re-pointed, the repairs have failed.

## PROBLEMS OF REPAIR

6. In the basement window well along the south elevation of the pavilion, the brick has been painted white. The paint has eroded. Steel pipe rail surrounding the window well has been let into the brick wall. The brick has been poorly cut out and repaired with mortar. The mortar has failed, and the brickwork is open to the weather.
7. The brick piers supporting the arched openings at the base of the hyphen's south elevation are spalling.
8. To the west of the hyphen the brick garden wall has efflorescence, open mortar joints, and cement mortar repairs of poor workmanship.
9. Pointing repairs have been made on the south elevation of the rear addition with a white cement mortar that does not match the earlier mortar. The new mortar was used to repair a large extent of the wall surface beneath the first-floor level.
10. At the rectangular-framed, elliptical window on the south elevation of the rear addition, the joint between the window frame and the masonry wall is open. Poorly executed mortar repairs have been attempted in this area.

## PORCHES

1. A porch with an arcaded screen extends along the north face of the connecting hyphen. The woodwork of the deck, stairway, columns, arcade, and balustrade is eroded. The paint is alligatored and peeling in large areas, exposing the wood substrate. Advanced mildew and algae extend over the balustrade, decking, and stair components. Joints in much of the woodwork are open. The outer edge of the porch decking is rotted. Surface-mounted wiring for a doorbell switch is routed along the west architrave of the porch entry. The door knocker has been removed, and gouges in the intermediate stile of the door are visible where the knocker had been attached.
2. A columned porch extends across the west elevation of the rear addition and rests on brick piers. The painted finish on the porch woodwork is dirty, eroded, and alligatored; mildew is visible over much of the painted surface. The painted finish on the wood stair and handrail has failed, exposing the wood substrate. Algae are growing on the surface of the woodwork along the north end of the porch. At the northwest corner of the porch the mitered joint of the fascia skirting the porch deck is open. The decking is moderately eroded, and the paint is peeling. The brick piers at the perimeter of the porch have been repointed with a cement mor-

## PAVILION V

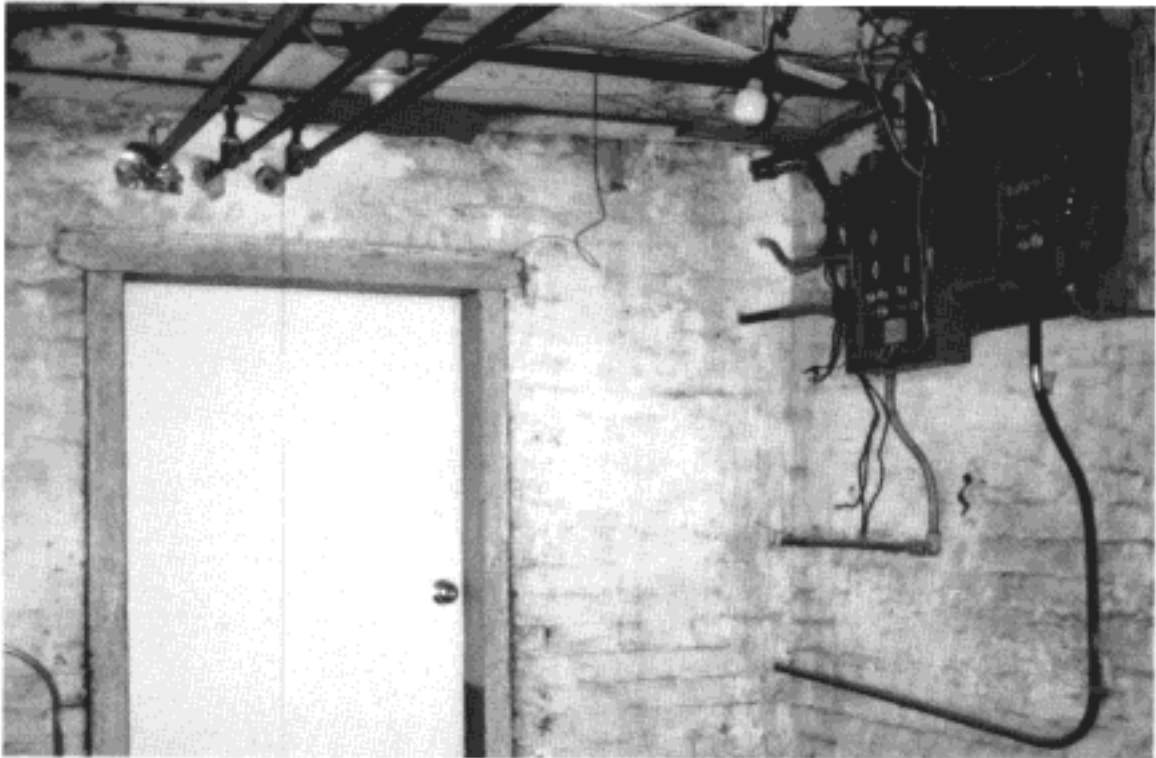

*Ad hoc installation of wiring and plumbing beneath the connecting hyphen*

tar. The mortar color is sympathetic to the color of the original mortar; however, the wide, flat, struck joints are inappropriate. Efflorescence is visible on the northwest pier. Inappropriate modern light fixtures have been mounted on the ceiling of the porch and on the west elevation of the rear addition. The electric wall sconce is serviced by surface-mounted conduit.

### AREAWAYS

1. A downspout from the roof above the student dormitory rooms and two downspouts at the northwest corner of the original building conduct water into the brick-paved areaway along the north and west elevations of the pavilion. Drainage in this area is not sufficient; much of the water filters into the ground at the base of the building. Many of the brick pavers in the areaway are broken, and the joints are open.
2. The wood lattice in the archways beneath the south elevation of the connecting hyphen is broken and in disrepair. In the brick areaway beneath the hyphen plas-

## PROBLEMS OF REPAIR

ter and lath are missing from the ceiling. Portions of the brickwork have been painted, and the paint has eroded to varying degrees. Mortar has been leached from joints in the brickwork at grade level. Heating pipes, plumbing lines, and electrical conduit have been suspended from or attached to the ceiling. A downspout in the southeast corner of the areaway has rusted through; the downspout extends from the plastered ceiling into a brick retaining wall.

### WINDOWS

1. On the east elevation of the building, the painted finish on the blinds and windows is dirty, and mildew appears to be growing on the blinds. Wire-mesh reinforcing and plastic sheeting extend across the basement window wells to the north of the entry. These materials appear to have been introduced with the installation of a concrete slab and brick paving beneath the colonnade. The protective horizontal wood bar in the basement window immediately north of the entry has been broken out of the window reveal.
2. On the north elevation of the building, the paint on the window sash, architraves, and sills is alligatored and peeling. Mildew is visible on the basement windows of the rear addition, and the sills of these windows are at or below grade level.
3. On the west elevation of the original building to the north of the hyphen, the paint on the window sash, architraves, and sills is alligatored; in isolated areas the paint is peeling.
4. On the west elevation of the rear addition, the paint on the basement-window openings is dirty and alligatored. The paint on the second-floor windows has failed, and the wood substrate of the sill at the northwest window is exposed. The northwest basement window has been converted to an entry; the replacement of the window with a door is an awkward and inappropriate modification. The joint between the brickwork and the wood enframing at this entry has been filled with mortar; the mortar has failed, and the joint remains open.
5. On the south elevation of the original building, the paint on the basement window architraves is alligatored and peeling, and the paint on the window sills is heavily eroded. The glazing compound in these windows is cracked and deteriorated. The glazing compound in the first- and second-floor windows is deteriorated, and the wood substrate of the muntins is exposed.
6. On the south elevation of the connecting hyphen, the woodwork surrounding the arched windows is deteriorated. The paint has failed, and the wood substrate is



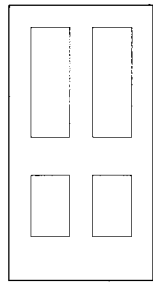

D-9

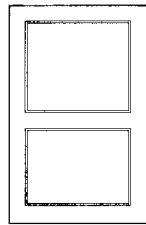
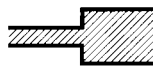

D-10

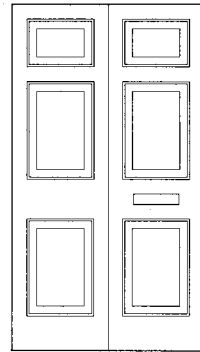

D-11

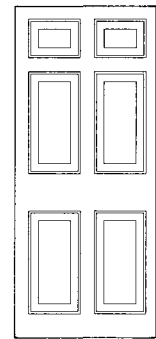
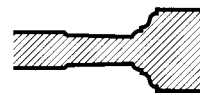

D-12

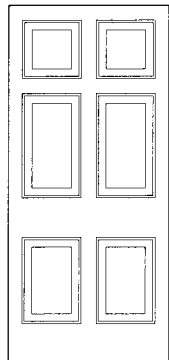

D-13

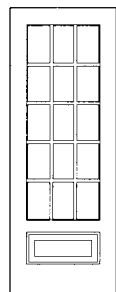

D-14

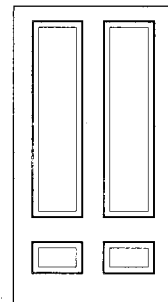

D-15

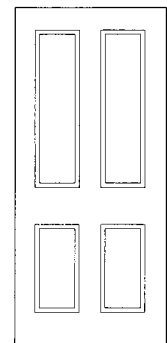
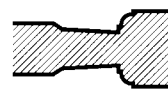

D-16

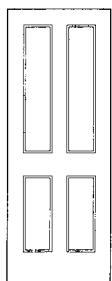

D-17

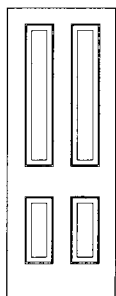

D-18

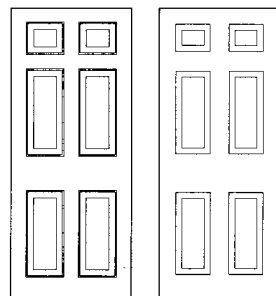

D-19

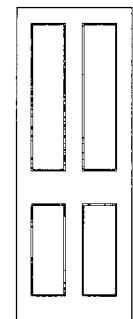
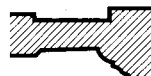

D-20

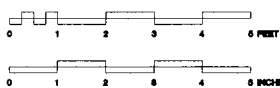
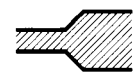

*Elevation and profiles of door types*

## PROBLEMS OF REPAIR



*Mid-twentieth century West Lawn heating main and electrical service*

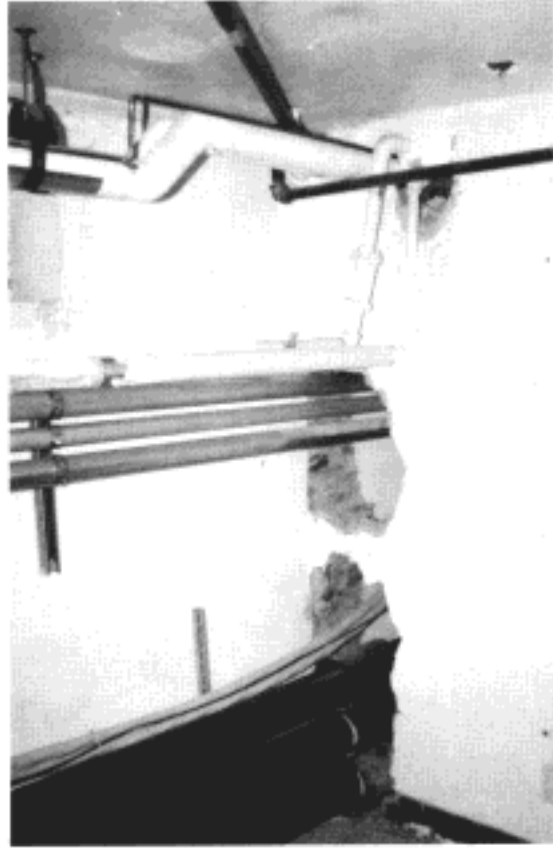

*Intervention in original building fabric for the installation of utilities*

exposed. Ferrous staining from nails is apparent. The woodwork has split, and joints have opened. The glazing compound in the windows is deteriorated and cracked.

7. The painted window blinds across the first- and second-floor levels of the south elevation have a chalky appearance, and the paint is visibly eroded. At the first floor southeast window, the lower west shutter pintle is hanging loosely from its mounting screws.

8. On the south elevation of the rear addition, the paint on the window architraves and sills has failed. The central basement window has an opening for a clothes-dryer vent.

## PAVILION V

### DOORS

1. The paint on the risers of the stone steps at the east entry is alligatored. The nosing of the upper tread is chipped at the northeast corner, and the stone plinth beneath the south door architrave is cracked. White cement has been used to repair a cavity in the stonework of the steps. The east entry door has been removed and temporarily replaced with a hinged plywood panel.
2. On the north elevation of the connecting hyphen, the paint on the first-floor door architrave and on the second-floor entry doors is alligatored. The joints at the base of the second-floor doors are open.
3. The paint at the southwest, second-floor entry to the original building is heavily eroded and uneven. The paint is alligatored and peeling. The outward-swinging screen door binds on the metal roofing of the terrace.
4. The paint on the west porch entries is dirty, alligatored, and mildewed. There is a bird's nest within the reveal of the transom above the northwest entry.
5. The painted finish on the stairs to the first-floor entry at the southwest corner of the hyphen has failed, and the wood substrate of the treads and landing is exposed. The painted finish of the door and surrounding architrave is alligatored and peeling. Joints in the woodwork are open, and splits have occurred in the stile-and-rail construction of the door. The metal screen in the outer door has been ripped. An inappropriate modern light fixture has been mounted on the wall adjacent to the door opening. The fixture is missing its bulb and globe.

### INTERIOR

The interior spaces of the building remain in relatively good condition despite the absence of a comprehensive maintenance program. As needs have changed, modifications have been made to the interior; generally, the modifications have corresponded with changes in occupancy.

The introduction of building systems, such as central heating, plumbing, and electricity, has been accomplished on an ad hoc basis. The insensitive installation of these systems has been an aesthetic imposition and a physical intrusion on the building.

The most radical alterations have occurred in utilitarian spaces, such as those found in the basement. Preservationists are beginning to recognize such areas for their intrinsic historic value, and preservation philosophy now embraces efforts to restore the original character of service-related spaces.

## PROBLEMS OF REPAIR

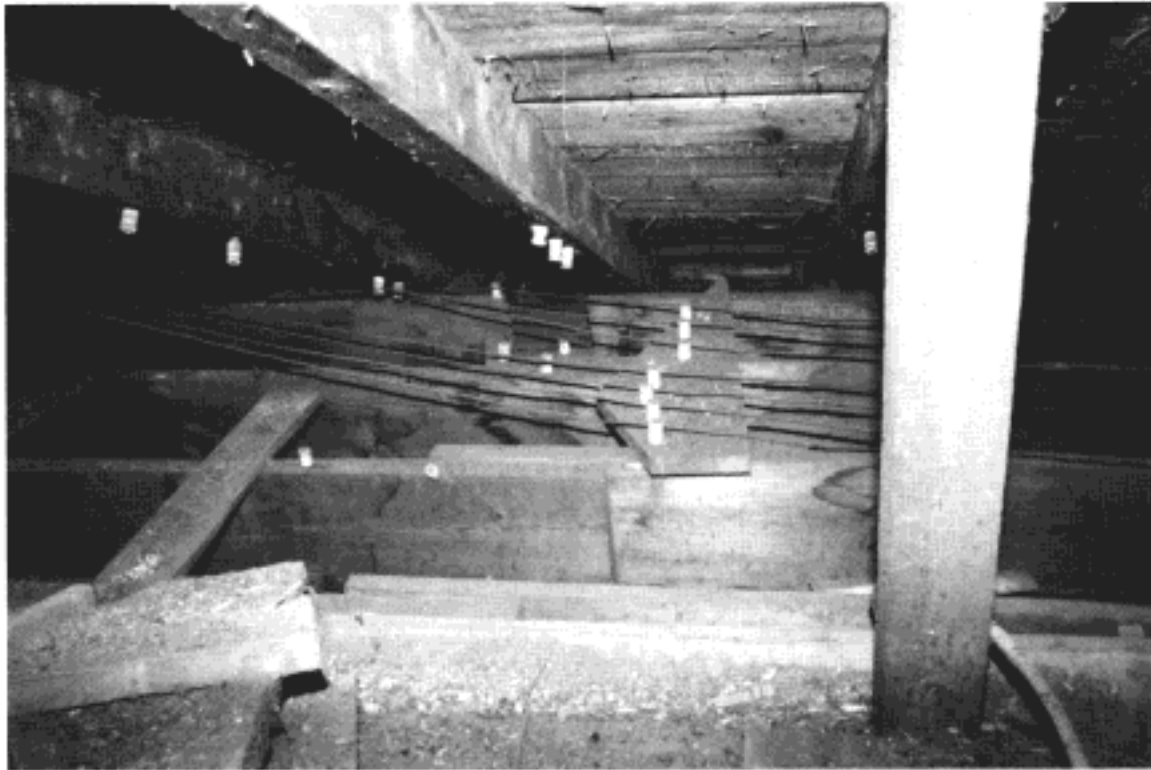

*Knob-and-tube wiring in the attic of the original building*

While individual problems are listed by room, there are several problems that re-occur throughout the building:

1. There are exposed electrical junction boxes on the walls and ceilings, where light fixtures have been removed. In other locations sheet-metal escutcheons cover electrical junction boxes where fixtures were once installed.
2. Holes have been drilled in the floor for piping at either end of cast-iron radiators. In many instances the paint on the radiators has peeled, and radiator enclosures have been screwed to plaster wall surfaces and architectural moldings.
3. Period locksets have been removed from doors on the first and second floors of the original building and replaced with modern mortised locksets.

## PAVILION V

### BASEMENT

#### ROOM B01 FRONT STAIR HALL

1. The West Lawn heating main and two electrical conduits are routed along the east wall of the stair hall. These lines extend through holes sawn in the risers of the stairway and through openings made in the north wall of the stair hall.

2. At the foot of the stairway electrical conduit, domestic water piping, pneumatic HVAC control tubing, and heating/cooling pipes span the north and south walls of the stair hall above the doorways. Openings have been cut in the walls for these lines.

3. The telephone service line is routed across the west wall of the stair hall and through openings in the north and south walls.

4. A twentieth-century light fixture has been recessed in the ceiling.

5. At the foot of the stairway a steel bracket and plastic identification tag for a fire extinguisher have been screwed to the south wall.

6. Vinyl treads have been tacked to the wood stair treads, and a vinyl mat has been tacked down to the stair landing at the top of the stairway.

7. There is paint peeling from the plastered surfaces. The plaster on the north wall is uneven in the vicinity of the conduit and piping. The wood paneling on the south wall has been broken and splintered; it is filled with putty.

8. The original flooring at the base of the stair has been replaced or covered with concrete.

9. There are holes and indentations in the plaster walls at the head of the stairway.

#### ROOM B01A CLOSET

1. The west lawn heating main is routed along the south and east walls of the closet. A large electrical junction box is located in the southeast corner of the closet. Conduit extends across the closet from the junction box to holes in the north and east walls.

2. Pneumatic HVAC control tubing and heating/cooling pipes are routed through the closet.

3. A domestic water line, radiator piping, and surface-mounted electrical conduit traverse the closet with holes cut through the north, south, and west walls and through the ceiling.

4. The original flooring has been replaced or covered with concrete. At the south end of the closet a large concrete repair has been broken.

5. Along the base of the south, east, and west walls, water has filtered up to the level of the exterior grade. The finishes have peeled, and much of the plaster is friable.

6. The plaster wall finish on the south and east walls near the southeast corner has a series of cracks above the level of the exterior grade.

7. The plastered undercarriage of the stairway is cracked, especially along the juncture of the stair and east wall. The plaster near the floor level is friable as a result of water damage.

8. The plaster ceiling at the south end of the closet is uneven and cracked.

9. Wood blocking has been attached to the splayed reveals of the south window and steel bars have been installed across the opening. One light in the lower sash is cracked. The intersection of the east stile and bottom rail of the lower sash is heavily eroded, as if gnawed.

#### ROOM B02 HALL

1. Surface-mounted electrical conduit extends across the ceiling and wall surfaces of the hall from a panel box on the south wall. An electrical disconnect for the hot-water heater is surface mounted to the south wall.

2. Domestic plumbing pipes are suspended from the ceiling; they extend the length of the hall, passing through openings in the north, south, and west walls. At the southwest corner of the hall waste lines extend beneath the finished ceiling.

3. Two large electrical conduits and the west lawn heating main span the east end of the hall. These lines are routed through holes in the north and south walls.

4. The telephone service line is mounted to the east wall and routed through holes in the north and south walls. A surface-mounted telephone junction box is attached to the east wall.

5. Pneumatic HVAC control tubing and two insulated heating/cooling pipes are suspended from the ceiling at the east end of the hall. These lines are routed through holes in the north and south walls.

6. The original flooring has been replaced or covered with concrete.

7. There are some cracks in the plastered wall and ceiling surfaces, and the painted finish is peeling throughout the hall. Marginal plaster repairs have been made in the southwest corner of the ceiling where several plumbing pipes protrude. Mois-

## PROBLEMS OF REPAIR

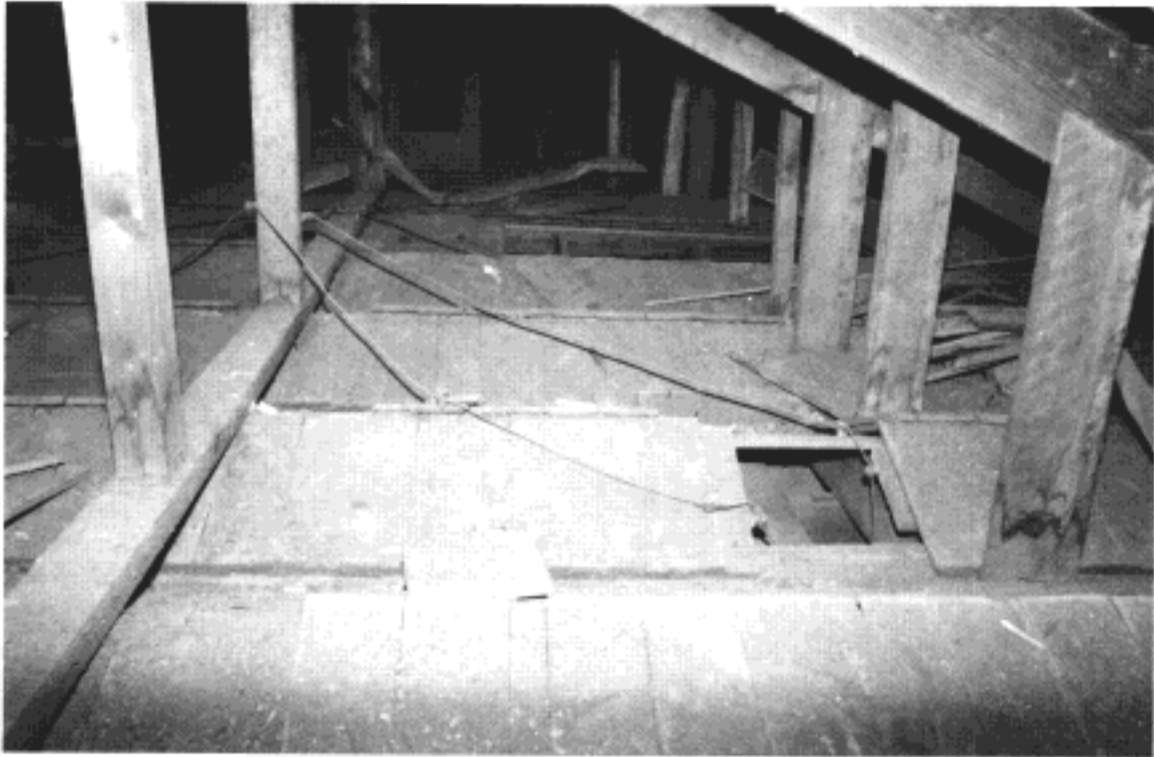

*Accumulated debris and fine, silt-like dust cover the encapsulated ridge-and-furrow roof*

ture-induced plaster deterioration has occurred in the northwest corner of the ceiling, where the plaster is friable.

8. The painted finish at the base of the west door and its surrounding architrave is peeling.

9. A steel bracket and plastic identification tag for a fire extinguisher have been screwed to the east architrave of the southwest door.

### ROOM B03 STORAGE

1. Heating pipes and electrical conduit are suspended from the ceiling or screwed directly to the ceiling. Heating pipes and electrical conduit extend across the east wall, passing through the north and south walls of the room. A large electrical pull box has been mounted to the north wall near the northeast corner. A single, large opening has been made near the center of the west wall, immediately beneath the ceiling, for the building's perimeter heating main. A hole has been made in the east wall, at the southeast corner, for a domestic water line.

2. One light in the upper sash of the window and one light in the lower sash are cracked. The sweep lock on the meeting rail has been moved due to deterioration of the rail at the previous location. The molding along the west reveal of the window has separated from the plaster wall surface.

3. The paint is peeling from the window sash and frames along the east wall.

4. There is significant water damage to the plaster at the juncture of the ceiling and north wall. The damage occurs in close proximity to the juncture of the pavilion and the rear wall of the student dormitories to the north.

5. Plaster cracks and areas of peeling paint are visible on the ceiling and on each of the walls of the room. Water droplet stains on the ceiling surface above much of the uninsulated heating pipe indicate that condensation has been a problem.

6. The original flooring has been replaced or covered with concrete.

7. The door to the room has been removed; the

## PAVILION V

hinge locations are splintered and have evidence of previous repairs.

### ROOM B04 WORKROOM

1. A cast-iron radiator is suspended from the ceiling in the northeast corner of the room, and exposed heating pipes extend across the northern end of the room, just below the ceiling. There are large openings in the east and west walls, near the center of the room, for the building's perimeter heating main. The masonry above the opening in the west wall is unsupported. There are smaller openings in the ceiling, along the north wall, for individual heating pipes to the radiators above. Water droplet stains on the ceiling surface above the radiator indicate that condensation has been a problem.

2. Surface-mounted electrical conduit is routed along the ceiling and walls, and a pendant-mounted fluorescent fixture is suspended from the ceiling. Obsolete telephone wiring is strung across the west wall.

3. Two of the lights in the upper sash of the northwest window (north wall) have compound cracks. One of the lights in the upper sash of the northwest window (west wall) has a single crack. Marginal repairs have been made to keep the sweep locks on the windows operational. Either the locks have been relocated or rudimentary dutchman repairs have been made to the meeting rails of the sash.

4. There are hairline plaster cracks and areas of peeling paint over much of the ceiling and wall surfaces. A prominent crack in the plaster generally follows the juncture of the ceiling and walls to the north and west. The crack descends at the northeast corner of the room to approximately the level of the exterior grade.

5. The original flooring has been replaced or covered with concrete.

6. A closet has been removed from the southeast corner of the room. Pock marks in the plaster wall and ceiling surfaces and in the concrete floor remain where framing was previously attached.

### ROOM B05 DEN (ORIGINAL KITCHEN)

1. The original flooring has been replaced or covered with concrete.

2. A cast-iron radiator is located against

the south wall and exposed heating pipes are suspended beneath the ceiling adjacent to the south and west walls. The heating main for the west lawn, as well as the perimeter main for the pavilion, enters the building through the south wall, at the southeast corner of the room. Two new heating/cooling pipes and pneumatic HVAC control tubing also enter the room at this location.

3. Surface-mounted electrical conduit and receptacles are attached to the walls.

4. Domestic plumbing pipes are suspended from the ceiling adjacent to the west wall. These lines enter through the north wall of the room and service Toilet Room B05A.

5. Two twentieth-century light fixtures have been recessed in the ceiling.

6. At the southwest window the window-stop moldings have been removed.

7. A single light in the lower sash of each of the south windows is cracked. The bottom rail of the lower sash in the southeast window is splintered. The sweep locks on the south windows are incomplete, and the sweep lock on the west window has been moved due to deterioration of the meeting rail.

8. Paint is peeling on each wall, to varying degrees. This is generally occurring above the level of the exterior grade. It appears that water infiltration has caused the paint failure at either end of the south wall.

9. The stub of a large (3-1/2") diameter conduit protrudes through the baseboard of the east wall at the southeast corner of the room. The conduit is mortared in place and cut off in Closet B01A. The conduit has no apparent use.

### ROOM B05A TOILET ROOM

1. Heating pipes are suspended beneath the ceiling along the south and west walls.

2. A twentieth-century light fixture has been recessed in the ceiling.

3. The painted finish on the ceiling and on the south and west walls is peeling. Significant horizontal cracks have developed in the plaster wall surface beneath the window.

4. Along the south wall the plywood platform for the water closet at the south end of the room is rotted.

5. A single light in the lower window sash is cracked.

## PROBLEMS OF REPAIR

### ROOM B06 LAUNDRY

1. Near the center of the room, the textured plaster ceiling exhibits evidence of plumbing leaks. The painted finish in this area has peeled, and the plaster is friable. Additional water damage is visible along the south edge of the ceiling. There are cracks in the ceiling plaster on the underside of the stair carriage to the southwest.

2. Domestic water pipes and electrical conduit extend across the ceiling. The base of a surface-mounted light fixture remains attached to the ceiling.

3. An exposed cast-iron waste line extends vertically through the southwest corner of the laundry. Electrical conduit and surface-mounted electrical receptacles are attached to the north and south walls.

4. A cast-iron radiator is suspended from the ceiling in the northeast corner of the room. The perimeter heating main for the building is suspended from the ceiling along the north wall.

5. A hole has been cut in the north wall for a clothes-dryer vent.

6. Water damaged plaster is visible at the eastern end of the room on the north and south walls and on the east wall north of the door. This appears to be the result of rising damp.

7. A single light in the upper window sash is cracked.

### ROOM B07 REAR STAIR HALL

1. The plaster surfaces in the northeast corner of the hall are friable; there appears to have been significant water infiltration. The plaster ceiling has areas of peeling paint.

2. Surface-mounted electrical conduit has been attached to the ceiling and to the east and west walls.

3. Domestic water pipes are suspended beneath the ceiling; they are connected to the water heater located in the northeast corner of the hall. The pipes extend through the masonry walls. An electrical disconnect and surface-mounted conduit for the hot water heater have been attached to the east wall.

4. The perimeter heating main for the building penetrates the east and west walls at the northern end of the hall and the east wall to the south of the door. The pipe to the south is routed through a riser in the basement stair. The northern section of pipe is suspended from the ceiling.

5. Inappropriate fiberboard finishes have been nailed to the framing at the south end of the hall and along the enclosure wall of the stairway.

6. The brick floor is worn and uneven. The brick is laid in a relatively soft mortar; however, there has been some repointing with cement mortar. At the north and south ends of the hall the mortar is significantly eroded.

7. During a previous renovation, cementitious repairs were made to the masonry walls in the hall. Between the doors to rooms B08 and B09 the cement has been coursed to resemble brick; this repair was poorly executed.

8. A cast-iron radiator is located against the north wall. The piping extending from the west end of the radiator is routed through the west wall.

9. At the northeast corner of the hall a cast-iron waste line and clean-out have been partially buried in the east wall.

10. The window on the north wall has splintered jambs and replacement hardware.

11. A solid-core wood replacement door with steel butt hinges and a brass-plated mortised passage set has been installed in the east door opening. The wood sill is cracked and appears to be rotted from contact with the damp brick paving. The inner face of the door frame has been augmented to accommodate the thick new door. The base of the north jamb has a poorly executed dutchman repair.

### ROOM B07A BATHROOM

1. The plastered ceiling surface is uneven and cracked.

2. The building's perimeter heating main penetrates the west wall and is routed through the fiberboard nailed to the underside of the stair carriage in the northeast corner of the room. The masonry opening in the west wall remains unsupported.

3. The heating main, two radiator pipes, a domestic water pipe, and a plumbing vent extend across the bathroom, from east to west, beneath the ceiling.

4. The original flooring has been replaced or covered with concrete.

5. Various holes have been made in the masonry of the west wall.

6. A heavy build-up of paint exists on the masonry wall surfaces. Delamination of the paint has occurred on the west wall.

7. Inappropriate fiberboard finishes have been



## PAVILION V

nailed to the north wall and to the underside of the stair carriage. Beneath the stairway, it appears that joint compound has been applied around the opening cut for the heating main; the workmanship is of a poor quality.

8. Poorly constructed modern shelving has been installed beneath the stairway.

### ROOM B08 STORAGE

1. The floor is of uneven brick laid in mortar. To the southwest the brick is broken, and the mortar is eroded. In the northeast corner the brick is broken in localized areas and has collapsed; a perimeter drain may exist beneath the floor. The sill at the southeast door is missing.

2. The window on the west wall has been converted to a half-height door. Freestanding wood steps have been constructed within the room to provide access to the opening. The inner screen door and outer paneled door have modern, brass-plated mortised hardware and steel butt hinges. The screen door binds on the uneven ceiling.

3. The ceiling has been completely covered with beaded board. The ceiling boards are irregularly laid in places. Access holes have been cut in the ceiling and covered with sheet metal. The building's perimeter heating main is suspended from the ceiling along the north and west walls; the pipe penetrates the south and east walls. The openings that have been cut in the masonry walls remain unsupported. Branch lines for the heating system penetrate the west wall at the southwest corner and the ceiling at the northwest corner. A cast-iron radiator is located on the floor in the northwest corner, and a branch line from the radiator extends across the north wall and passes through the east wall at its base.

4. Surface-mounted electrical conduit has been attached to the ceiling and to the north, south, and east walls.

5. The mantel above the fireplace in the southwest corner is missing.

6. The northwest window sill is eroded but sound; the northeast sill and window apron have been replaced with modern materials.

7. A telephone jack has been surface-mounted to the west architrave of the northeast window. Telephone station wire has been routed over finished surfaces on the north and east walls.

8. The latch hardware on the southeast door is inoperable and incomplete. Two of the recessed

panels within the door are split vertically.

9. Television coaxial cable is routed through the south wall and is stapled to the ceiling.

### ROOM B09 STORAGE

1. The original flooring has been replaced or covered with concrete. A single crack extends through the center of the concrete floor from east to west.

2. The ceiling has an uneven plaster finish. The paint is peeling in the southeast quadrant, and there is evidence of plaster repairs above the suspended heating lines.

3. Surface-mounted electrical conduit is attached to the ceiling and walls. At the southeast corner, domestic water supply and waste lines for a washing machine protrude from the east wall.

4. Domestic water lines are suspended from the ceiling along the north and east walls of the room.

5. The perimeter heating main for the building is suspended from the ceiling along the south and west walls; the pipe passes through the north and east walls. The openings that have been cut in the masonry walls remain unsupported. Paint is peeling from the wall areas surrounding the openings. In the southeast corner, noticeable plaster deterioration has occurred. Branch lines of the heating system pass through the south wall at the southwest corner, the east wall at the southeast corner, and the ceiling in the southeast corner.

6. A plywood closet with sliding doors is located in the southwest corner of the room. The closet detracts from the spatial layout of the room, and it is incompatible with its historic interior.

7. A single light in the southwest window sash is cracked. One light in the southeast window sash has been replaced with a clothes dryer vent and a second light is cracked. One light in the lower sash of the west window is cracked.

8. In the northwest corner, overlapping sheet-metal plates have been nailed to the face of the chimney mass just below the ceiling. The purpose of these plates is not apparent.

## FIRST FLOOR

### ROOM 101 ENTRANCE HALL

1. Two of the lights in the fanlight above the east door have cracks.

## PROBLEMS OF REPAIR



*Deteriorated mortar at the base of the original chimney*

### ROOM 101A HALL

1. Differential movement has occurred between the east wall of the hall and the flanking walls to the north and south. The plaster has separated at the juncture of these wall surfaces, probably as a result of interaction between the original walls and the east wall, which was a later insertion.

2. Hairline plaster cracks and peeling paint are visible on the north and south walls. At the eastern end of the hall, the paint on the ceiling is peeling.

3. A surface-mounted telephone junction block is screwed to the baseboard on the south wall.

4. A plaster crack extends between the west architrave of the southwest door and the cornice molding above.

5. The blind-splice joints in the cornice molding have become visible with the movement of the moldings.

6. Near the center of the south wall the chair rail has separated from the plaster wall surface.

### ROOM 101B TOILET ROOM

1. The original exterior door architrave, jamb, and transom on the west wall have been uncovered; they remain in relatively good condition despite being encased by alterations. The transom above the door has one broken light. Nail holes are visible over most of the moldings. The original chair-rail and baseboard moldings have survived on the west wall; however, only the baseboard remains on the north and south walls.

2. Holes have been drilled in the floorboard adjacent to the north wall for supply and waste pipes associated with the lavatory and with the plumbing on the second floor. At the south end of the space the flooring has been cut out for the water closet supply and waste pipes.

3. Above the level of the dropped ceiling in Toilet Room 101B the original cornice has been removed from the west wall. The cornice moldings on the north and south walls remain; however, the plas-

## PAVILION V

ter and much of the split lath of the original ceiling is missing. The mitered corner of the cornice molding on the north wall has been cut off to create a chase for a plumbing vent and exhaust duct.

4. Early plaster remains on the north, south, and west walls; however, it has been pock-marked with nail holes. Holes have been cut in the plaster on the north wall for electrical wiring.

### ROOM 102 LIVING ROOM

1. In the southeast and northwest corners of the room holes have been drilled in the floor and in the wood cornice moldings for exposed heating pipes.

2. One light in the upper sash of the northeast window has a compound crack. Two lights in the upper sash of the north window on the west wall are cracked.

3. A crack in the wall plaster extends between the architrave of the southeast door and the cornice molding above. Relatively minor plaster cracks are visible above the northeast window architrave and the southwest door architrave.

4. The outer molding of the architrave at the southeast window has been cut to accommodate a radiator enclosure.

5. The architectural moldings have separated from the plaster wall surface at the western end of the north wall.

6. The raised paneling beneath the windows on the north and west walls has separated along the horizontal seams in the paneling. The paint on these panels is peeling.

7. The raised paneling in the southwest door is split diagonally. The interior faces of both doors have been damaged where the hinged stiles of the doors have bound on the plinth blocks beneath the architraves.

8. The wood mantel has separated from the plaster wall surface of the chimney breast.

### ROOM 103 DINING ROOM

1. To the north of the radiator on the west wall a hole has been drilled in the flooring, and a second hole has been chiseled through the brick wall to run a 1/4" diameter water line from the basement to the refrigerator icemaker located in Kitchen 106.

2. Radiator enclosures were screwed to the window architrave moldings and to the raised paneling beneath the south window. The panel has separated along its horizontal seam, and the paint on the pan-

eling is alligatored and peeling as a result of high temperature levels attained by the radiator.

3. Two lights in the lower sash of the south window are cracked.

4. The two original window openings on the west wall have been altered. The northwest opening has been closed and shelving has been constructed within the window reveal. The southwest opening has been converted to a doorway. The door is mounted on modern spring hinges. The shelving, the swinging door, and the infill paneling are of an inappropriate character for an historic interior.

5. Steel fire extinguisher brackets and plastic identification tags have been screwed to the chair rail in the northeast and northwest corners of the room.

6. Plaster cracks extend between the original window architraves on the west wall and the cornice molding above. On the south wall, to the west of the window, there are minor plaster cracks extending between the chair rail and baseboard.

7. On the north wall, above the chair rail, the mantle and fireplace surround have separated from the plaster wall surface.

8. Above the fireplace, holes have been drilled in the plaster wall surface for anchors and picture hangers.

9. A modern coat hook has been screwed to the south face of the northwest door, and the lower hinge of the door is completely detached from the door jamb.

### ROOM 104 FRONT STAIR HALL

1. Hairline plaster cracks extend between the architrave of the southeast window and the window above.

2. The fluted wood pilasters flanking the arched opening on the north wall have separated along blind vertical joints.

3. One light in the upper sash of the northeast window is cracked.

4. Along the south wall there is a noticeable separation between the baseboard cap molding and the plaster wall surface.

### ROOM 105 VESTIBULE

1. Near the midpoint of the south wall a vertical chase was constructed to house domestic plumbing pipes, a waste pipe, and rigid electrical conduit.

## PROBLEMS OF REPAIR

2. Water leaks from the second floor bathrooms have damaged the ceiling plaster; the plaster is friable.

3. The paint on the north wall is peeling in isolated areas. Much of the finish on the walls of the vestibule is uneven; it appears that remnants of wall-paper remain beneath the painted finish.

4. An electric doorbell mechanism (clapper and bell) is attached to the north wall above the west architrave of the door. Wiring for the bell is stapled to the outer molding of the door architrave and is routed through holes drilled in the architrave moldings.

5. Screw holes remain in the architrave and west stile of the north door, where a horizontal surface bolt has been removed. Filler has been used to obscure holes in the intermediate door stile where a door knocker was once installed, and the painted finish on the door is peeling.

6. A telephone wiring block is mounted to the baseboard on the north wall. Telephone station wire is stapled to the perimeter baseboard and to the architrave of the south door.

7. There is a vertical split in one of the upper recessed panels of the south door.

### ROOM 105A STAIR

1. Paint is peeling from the plaster ceiling and wall surfaces of the stair hall.

2. Exposed heating pipes pass through the beaded-board wainscot on the west wall. Water has leaked from this piping and caused substantial plaster damage in the southeast corner of the stair hall.

3. Near the southwest corner, a portion of the chair rail is missing.

4. The beaded wainscot on the east wall has buckled near the midpoint of the stairway, and the painted finish on the wainscot has peeled. This damage appears to be the result of water infiltration.

5. Sheet flooring has been applied to the landing, obscuring the wood floor beneath. A rubber foot mat has adhered to the sheet flooring at the east side of the landing.

6. The lockset on the north door is loose.

### ROOM 106 KITCHEN

1. The plaster ceiling is uneven; peeling paint and plaster cracks are visible. There is evidence of water damage surrounding an electrical junction box in the ceiling; the plaster is friable.

2. The brick wall to the north was once an exte-

rior wall surface. Brick and mortar repairs were made with a grey mortar to which a pink coating was applied. Neither the mortar nor the coating matches existing materials. The mortar is moderately hard and may contain portland cement.

3. Near the center of the north wall, above counter height, a duplex receptacle has been recessed into the masonry.

### ROOM 106A BREAKFAST ROOM

1. The painted ceiling finish is peeling at the west end of the room. Severe plaster deterioration has occurred above the central window in the south wall; water infiltration has caused the plaster to become friable.

2. A surface-mounted duplex receptacle has been attached to the south wall at the east end of the radiator. Conduit from the receptacle has been routed through a hole drilled in the floor.

3. Telephone station wire protrudes from a hole in the south wall that is located between the two western windows.

4. The original window opening on the east wall has been reconfigured as a doorway, and infill panels have been constructed above the door. Modern hardware has been installed for a swinging door. The swinging door and the infill paneling are of an inappropriate character for an historic interior.

5. One light in the upper sash of the west window on the south wall is cracked, and one light is broken. Three lights in the lower sash are cracked.

6. One light in the upper sash of the central window on the south wall is cracked. Two lights in the lower sash are cracked.

7. Two lights in the upper sash of the east window on the south wall are cracked; one has compound fractures. Three lights in the lower sash are cracked.

8. One light in the fanlight above the west door is cracked.

9. The paint on the architraves of the south windows is cracked and delaminating, especially at the juncture of the architraves and walls. The paint on the sill of the west window has delaminated. The sill is eroded and water damaged; the wood has opened along the grain.

10. The muntins on the south window sash have varying degrees of paint delamination. At the west window, the muntins in the lower half of the upper sash are heavily deteriorated. Paint delamination is advanced, and water damage is visible.

## PAVILION V

### ROOM 107 REAR STAIR HALL

1. There are minor plaster cracks on the underside of the stairway at the southwest corner of the hall.

2. The finishes within the hall are dirty. The paint on the wood trim is peeling, and the paint on the door architraves along the west wall is alligatored. The paint on the recessed panels of the south door is alligatored as well. The stained finish on the stair treads is worn, and the nosings are eroded. The paint on the stair risers is peeling.

3. There are plaster cracks above the door architraves on the west wall. In the southwest corner there is a significant plaster crack that extends from the baseboard to the height of the upper architrave of the south door.

### ROOM 107A STAIR LANDING

1. A bare-bulb light fixture and surface-mounted conduit have been attached to the ceiling.

2. The paint on the ceiling and wall surfaces is peeling. All finishes are dirty.

3. The stained finish on the wood flooring is worn. A carpet mat is nailed to the floor adjacent to the northwest door.

4. The paint on the blind door to the west is alligatored and gouged.

5. The northeast door binds on the floor. A surface bolt has been attached to the north face of the door; the bolt is mounted to a block of wood that is nailed to the face of the door.

6. Modern shelving has been attached to the south wall of the stair landing with little regard for the space or for the earlier materials.

### ROOM 108 KITCHEN

1. The architrave moldings at the base of the north window have been cut off, and the interior sill has been cut back flush with the plaster-wall surface to accommodate the kitchen casework.

2. Three lights in the upper window sash and one light in the lower sash are cracked. The paint on the sash and sill is alligatored, and much of the paint on the sill is eroded. The sweep lock for the upper sash was mounted to a wood block that has pulled loose.

3. In localized areas, the plaster finish on the ceiling is uneven, and the paint is peeling. A circline fluorescent fixture is mounted to the ceiling.

4. The finishes in the kitchen are extremely dirty.

5. The kitchen door is binding on the west jamb; the wood is abraded.

### ROOM 109 DINING ROOM

1. The window stop moldings have been removed from the north window, and the sash cord is missing. The sash are nailed in place. The sweep lock has been relocated due to the deteriorated condition of the meeting rail.

2. There are cracks in the plaster ceiling.

3. There is a significant crack in the plaster on the north wall that extends vertically from the baseboard to the head of the window and runs along the east architrave of the window; the crack continues in a horizontal line from the upper window architrave to the east wall.

4. The finishes in the dining room are extremely dirty. Paint is peeling in localized areas on each wall. The painted finish on the north and west walls has alligatored in large flake-like segments, 2" to 3" across.

5. There is a significant crack in the plaster on the east wall, adjacent to the northeast corner. The crack extends vertically from the baseboard to just below the ceiling and then extends in a horizontal line toward the door opening. The painted finish is peeling along the horizontal leg of the crack.

6. There are holes in the plaster on each wall where masonry anchors have been removed. The holes on the north and east walls and on the southwest chimney mass are pronounced.

7. Vertical plaster cracks are visible at either side of the chimney mass. It appears that there has been differential settlement between the chimney stack and walls.

8. The paint on the south door is alligatored and peeling.

9. Modern surface bolts have been attached to both leaves of the west door. The beaded molding along the leading edge of the south door leaf is splintered in the area adjacent to the strike.

### ROOM 110 PARLOR

1. The ceiling plaster in the southwest corner of the room appears to be water damaged; the plaster is friable.

2. The finishes in the parlor are extremely dirty. Paint is peeling in large areas on each wall. In the

## PROBLEMS OF REPAIR

southwest corner and on the west wall, north of the door opening, the painted finish has alligatored in large flake-like segments, 2" to 3" across.

3. The paint on the window architraves and sash and the paint on the north and northeast door architraves is alligatored and delaminating. A similar condition exists at the wood fireplace surround. The trim in this room has been gouged.

4. The paint on the plaster fascia around the firebox is peeling.

5. The mortised lockset at the west door is not in proper operating condition; the set screw on the knob is not seated.

6. One light in the upper sash of the southeast window and two lights in the lower sash are cracked. Half of the sweep lock is missing at the southeast window. The painted finish on the window sills is eroded and peeling, and water staining on the sills and sash is apparent.

### SECOND FLOOR

#### ROOM 201 FRONT STAIR HALL

1. Two lights in the lower sash of the northeast window are cracked, and one light in the upper sash is chipped.

2. There are hairline plaster cracks extending between the upper architrave of the northeast window and the cornice.

3. The painted finish on the stair handrail is alligatored.

#### ROOM 202 HALL

1. Four plywood closets with sliding doors have been placed against the north and south walls of the hallway. The closets detract from the spatial layout of the hall and are incompatible with the historic interior. Ledger strips have been fastened to the plaster wall surface above each closet to retain the closets against the walls.

2. A pipe chase covered with plasterboard is located in the northwest corner of the hallway. Extending from floor to ceiling, the chase contains a plumbing vent and exhaust duct for Toilet Room 101B.

3. The original window opening on the west wall was converted to a doorway for Bathroom 206B. There are hairline plaster cracks above the door architrave, and previous plaster repair is evident to the

south of the opening.

4. There are hairline plaster cracks on the north and south walls immediately west of the chimney mass and on the west face of the chimney mass above the masonry vault spanning the hallway. There is some peeling paint in this area as well. The problems appear to be the result of differential settlement between the chimney and building and of minor moisture infiltration at chimney flashings.

5. A plaster crack extends from the attic access hatch west of the chimney to the north wall of the hall.

6. It appears that the original cornice molding has been removed from the hall. Only a simple 1-3/4" ± perimeter molding remains to either side of the chimney mass.

7. A steel bracket for a fire extinguisher has been screwed to the north architrave of the arched opening at the east end of the chimney mass.

8. The south baseboard and cap molding have separated from the plaster wall surface within the vault spanning the hallway.

9. Some gaps and splits in the flooring can be seen to the east of the chimney mass. Two holes (5/8" ± diameter) have been drilled in the floor at the southeast corner of the chimney mass. These holes appear to have been used for early electrical wiring.

10. Inappropriate, modern surface bolts have been mounted to the interior face of the doors at the east end of the hall.

#### ROOM 203 STUDY

1. One light in the lower sash of the southeast window is cracked. One light in the upper and one in the lower sash of the northeast window are cracked. One light in the lower sash of the north window is cracked.

2. The lower sash of the north window has been raised approximately 8" and held in place with a blind panel. This alteration was made to accommodate the introduction of a gabled roof on the range of student rooms to the north of Pavilion V; the modification was poorly designed.

3. It appears that the original baseboard moldings on the east and west walls were cut off for the installation of shelving along the north wall. Immediately west of the north window, a surface-mounted duplex receptacle is attached to the plaster wall surface at the back of the shelving. Surface-mounted conduit extends vertically from the receptacle to the head height of the window; the conduit continues

## PAVILION V

horizontally to the west wall.

4. The paint is peeling from the plaster wall surface behind the shelving on the north wall. This deterioration appears to be confined to the wall surface east of the window.

5. Peeling paint is visible on the east wall.

6. Hairline plaster cracks extend upward from the door architrave on the south wall.

7. In the southwest corner of the room the mantel and fireplace surround have separated from the plaster wall surface. An awkward condition exists at the juncture of the fireplace surround and floor: to the northwest, sheet metal has been placed between the architrave moldings of the fireplace surround and the floor; to the southeast, the wood flooring is splintered or chiseled beneath the architrave moldings.

8. The baseboard and cap molding at the north end of the west wall have separated from the wall surface.

9. The cornice moldings above the intermediate fascia on the south wall have separated.

10. Coaxial television cable enters the room at the juncture of the floor and frame of the southeast window. Telephone station wire enters the study through a hole drilled in the frame of the north window. The wire is stapled to the east reveal and architrave of the window.

11. Upper and lower door hinges are screwed to the jamb with one screw each. Some impact damage has occurred to the door and surrounding moldings where the west stile of the door has come in contact with the plinth block beneath the west door architrave.

### ROOM 204 BEDROOM

1. Three lights in the upper sash of the northeast window are cracked. Two lights in the upper sash of the west window on the north wall are cracked. Two lights in the upper sash of the north window on the west wall are cracked, and one light in the lower sash is cracked.

2. A surface-mounted duplex receptacle has been attached to the north wall, immediately east of the west window. Surface-mounted conduit extends vertically from the outlet to the height of the window head; the conduit continues horizontally to the east wall.

3. There are hairline plaster cracks and minor areas of peeling paint on each of the walls.

4. In the southeast corner of the room the fire-

place surround has separated from the plaster wall surface.

5. Two vertically aligned holes have been drilled through the intermediate stile and rail of the door, approximately 5' 6" above the finished floor.

6. The hinged stile of the door has been scraped to prevent binding at the jamb. The careless scraping has removed all finishes.

7. The plaster ceiling has hairline cracks.

### ROOM 205 MASTER BEDROOM

1. One light in the upper sash of the south window is cracked.

2. Peeling paint and hairline plaster cracks are visible on the ceiling and on the north, south and west walls.

3. In the northeast corner of the room, a vertical plaster crack on the east wall extends between the chair rail and cornice. Previous plaster repairs are visible along the crack. At this same location, disrupted finishes on the baseboard, chair rail, and wall surface may indicate the previous installation of framing for a closet between the east wall and the projecting chimney mass to the west.

4. The fascia above the architrave of the fireplace surround has a long horizontal split.

5. The definition of many decorative elements in the ornamental frieze has been obscured by the build up of paint coatings. Several decorative elements, including guttae and medallions, are missing from the cornice. Several bucrania are chipped.

6. The east door has a vertical split through one of the raised panels beneath the lock rail.

### ROOM 206 VESTIBULE, ROOM 206A BATHROOM, ROOM 206B BATHROOM

Prior to the survey of this area significant removals were undertaken. The bathroom fixtures were removed, and partition walls between these spaces were demolished. Plaster rubble obscured the flooring at the time of this survey.

1. Modern light fixtures remain attached to the ceiling in this area, and electrical conduit and cable hang down from the ceiling where partitions once existed.

2. The sill of the northeast window has been split, probably with the removal of casework from the northeast corner. The paint on the window sill is peeling as a result of water infiltration.

## PROBLEMS OF REPAIR

3. The muntins in the north doors are water stained. At the bottom of the doors the stiles and rails are water damaged. The west door has obvious rot.

4. The paint on the plaster wall surfaces in the northwest corner is peeling.

5. Ceramic tile and plaster have been removed from the south wall. The removal of the tile and its cement base caused the soft, circa 1850 brick construction of the wall to spall; the face of the brick remains attached to the cement.

### ROOM 207 STORAGE

1. An inappropriate, modern light fixture is mounted on the ceiling. Minor plaster cracks are visible on the ceiling surface.

2. The paint on each of the plastered walls is peeling. Severe water damage has occurred on the south wall beneath the window sill; the paint is peeling, and the plaster is friable.

3. The window sill has been covered with an adhesive vinyl film; paint erosion is visible where the vinyl has delaminated. The paint on the window sash and architraves is peeling. The bottom rail of the lower window sash has significant water damage; the joints between the rail and stiles have opened. The window stop moldings are missing, and the lower sash is held in place with nails.

4. Television coaxial cable is routed through a hole drilled in the west end of the window apron.

5. Holes remain in the north wall where anchors were inserted for shelving.

6. Modern clothes hooks have been screwed to the south face of the door. The lower hook is broken off.

### ROOM 208 BATHROOM

1. Minor plaster cracks are visible on the ceiling surface.

2. Modern plywood casework is attached to the north wall in the northeast corner of the bathroom.

3. One light in the upper window sash is cracked, and one light is broken.

### ROOM 209 STAIR HALL

1. The plaster ceiling has severe water damage at the juncture with the east wall. The paint is peeling, and the plaster is friable.

2. The finishes in the stair hall are dirty. The stained finish on the stair treads is worn, and the

nosings have been eroded by foot traffic. The paint on the risers and on much of the baseboards is delaminating.

3. The window in the south wall has five cracked lights. The paint on the sash, jambs, and architraves is alligatored. The paint on the muntins is peeling, and the muntins are water damaged. Water infiltration at the perimeter of the window opening, especially to the east, has caused the paint on the casework beneath the window to peel.

4. Telephone station wire has been stapled to the baseboards and stair header at the south end of the hall. A surface-mounted telephone jack has been attached to the baseboard on the east wall, south of the door opening.

5. The door architraves and baseboards are scuffed and nicked. The baseboard between the door openings on the west wall has been pried loose.

6. The paint on the west door reveals is alligatored. The paint on the overhead reveal of the east door is peeling.

### ROOM 210 BATHROOM, ROOM 209A CLOSET

Prior to the survey of this area significant removals were undertaken.

1. One light in the lower window sash is cracked, and one light is broken.

2. The painted finish on the window architraves, jambs, and sash is alligatored.

3. At the juncture of the ceiling and north wall of the bathroom the paint is peeling, and the plaster is friable.

4. In the northeast corner of the bathroom the paint on the north wall is peeling.

5. The painted finish on the west face of the bathroom door is alligatored.

6. The plaster finishes on the ceiling and on the east and west wall surfaces have been disrupted by the removal of the framed partition at the south end of the room.

7. The painted finishes on the east and west walls of the former closet (Room 209A) are peeling.

### ROOM 211 BEDROOM

1. Severe water damage is apparent at the juncture of the ceiling and the north wall and at the juncture of the ceiling and the west wall. In these locations the painted finish has peeled, and the plas-



## PAVILION V

ter is friable. Additional water damage is visible in the southwest quadrant of the ceiling.

2. Plaster cracks and peeling paint are visible on each of the walls. The cracks have occurred around the window and door openings and at the juncture of the south wall and the chimney mass.

3. Two lights in the lower sash of the west window are cracked, and half of the sweep lock is missing. One light in the lower sash of the north window is cracked. The painted finish on the window architraves and sash is alligatored. The paint on the west window sill is alligatored and peeling as a result of water damage.

4. A plywood closet with sliding doors is located in the northeast corner of the room. The closet detracts from the spatial layout of the room, and it is incompatible with the historic interior.

5. The painted finish on the southeast door is alligatored and peeling; one of the recessed panels in the door is split. The paint on the south architrave of the northeast door is alligatored.

6. The finishes in the bedroom are dirty.

### ROOM 212 BEDROOM

1. There is significant water damage to the plaster ceiling above the bedroom door; the plaster in this location is friable. The ceiling above the west window is water stained, and small areas of friable plaster are visible.

2. Plaster cracks and peeling paint are visible on each of the walls. The cracks have occurred around the window and door openings and at the juncture of the north wall and the chimney mass.

3. South of the doorway, a vertical plaster crack extends up the east wall; the crack continues horizontally beneath the ceiling to the south wall.

4. The finishes in the bedroom are dirty.

5. Paint is peeling from the plaster fascia surrounding the firebox and from the moldings of the fireplace surround.

6. Two lights in the upper sash of the west window are cracked; one light in the lower sash is cracked. One light in the upper sash of the southwest window is cracked; three lights in the lower sash are cracked.

7. The painted finish on the window jambs, architraves, and sash is alligatored. The sill of the west window has been covered with an adhesive vinyl film. The paint on the window sills along the south wall is peeling. At the southwest window, water damage is visible on the bottom rail of the lower sash. Half of the sweep lock at the southeast window is missing. The sweep lock on the upper sash of the west window has been mounted on a supplementary block of wood; as an expedient repair.

8. The painted finish on the door is alligatored, and the paint is peeling in localized areas.

9. A surface-mounted telephone jack has been attached to the baseboard on the east wall. Station wire is stapled to the baseboard and is routed through a hole drilled in the south door architrave.

### ATTIC

1. Thomas Jefferson's ridge-and-furrow roof system, encapsulated beneath the mid-nineteenth century hipped roof, is covered with fine, silt-like black dust.

2. Holes have been cut in the ridge-and-furrow roofing system. Since the early roofing serves as the floor surface in the attic, these openings are safety hazards.

3. The mortar used in the construction of the chimney has deteriorated in some locations; there has been a loss of adhesion between the mortar and brick.

4. The chimney has been stained by the infiltration of water at the perimeter flashing. There is a build-up of debris around the base of the chimney and on the stepped masonry shelf of the original stack.

5. Knob-and-tube wiring is strung across the ridge-and-furrow roof. While this wiring is an important artifact dating to the electrification of the building, its continued use is an electrical shock and fire hazard.

6. The installation of large new mechanical units in the attic resulted in the removal of the original roof access hatch, which became the attic access opening. The original opening was enlarged and the associated tin-plate flashing was removed.

## PROBLEMS OF REPAIR

### UTILITY SYSTEMS

#### ELECTRICAL SYSTEM

Portions of the existing electrical system date to the late nineteenth or early twentieth century. Knob-and-tube wiring remains in place, especially in the attic of the original building. The continued use of this wiring is an electrical shock and fire hazard.

As the demand for electrical service has grown, new circuits have been added in an ad hoc manner, with little sensitivity for the historic quality of the building. Surface-mounted conduit and panel boxes are visible throughout the original building and subsequent additions. Holes have been drilled in flooring, intrusive chases have been constructed, and, most recently, original building materials have been channeled to receive new wiring and conduit.

All existing light fixtures are inappropriate to the historic quality of the building.

#### HVAC SYSTEM

A circulating hot-water system is used to heat the building. The water is supplied by a remote heating plant and distributed to cast-iron radiators throughout the building. Generally, the water distribution pipes have not been concealed. The pipes are routed through holes drilled in the flooring, and risers extend from floor to ceiling through inhabited spaces. The heating pipes are especially obtrusive in the basement, where a perimeter heating main is suspended from the ceiling; secondary piping supplies water to radiators in the basement and to the rooms above. In some areas the uninsulated heating pipes have dried out adjacent building materials, and they have caused condensation to form on cooler surfaces in close proximity to the pipes. Exposed pneumatic control lines for the heating system are also visually intrusive.

#### PLUMBING SYSTEM

The plumbing consists primarily of galvanized-steel supply pipe and cast-iron hub-and-spigot soil pipe. This system, probably installed in the first half of the twentieth century, has been augmented with copper supply tubing. Much of the piping is exposed. The plumbing system appears to be near the end of its useful life; visible

## PAVILION V

corrosion and damage associated with plumbing leaks are apparent throughout the building.

Plumbing fixtures appear to have been replaced as required. The dates of manufacture span most of the twentieth century. Hot water heaters have been obtrusively installed in basement hallways.

### FIRE DETECTION/SUPPRESSION SYSTEMS

Rudimentary fire detection is provided by independent, battery-operated smoke detectors. Fire extinguishers constitute the only system for fire suppression. The existing fire extinguishers have been installed with little sensitivity for the historic building fabric; brackets and labels have been mounted directly to architectural moldings.

## PAVILION V

# RECOMMENDATIONS FOR REPAIR AND RESTORATION

**T**his historic structure report serves as both an archival and physical survey of the construction, history and current condition of Pavilion V, as well as a framework for conducting the current restoration effort and for guiding future work. The report provides directions, which if followed, will help to ensure that the integrity of the structure is not compromised and its remaining historic building fabric is preserved intact, while necessary modifications are made to accommodate modern functional requirements, such as bathrooms and kitchens.

Previous modifications that have compromised the historic character of the building and caused physical damage should be reversed. New work must be based on the physical and documentary evidence summarized in this report. It needs to be realized that restoration efforts should not be founded on romantic interpretations of past conditions, nor on expedient, pseudo-historic design considerations. It is the artifact, or building, that is of lasting value, and it is the integrity of the building that must be preserved. While the conflicting agendas of preservation and modern residential accommodation temper the response of architects, engineers and tradesmen, it must be recognized that occupants will come and go along with systems that provide for their comfort. The building must be preserved as a testament to the architectural and construction genius of Thomas Jefferson.

### APPROACH TO RESTORATION

The restoration of Jefferson's buildings at the university should be approached from a curatorial perspective. Each building should be regarded as a rare object of art or as a valuable piece of furniture, and it should be entrusted only to the care of architects and craftsmen trained in the conservation of historic building fabric.



D-21

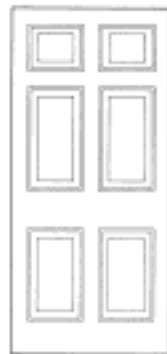

D-22



D-23



D-24

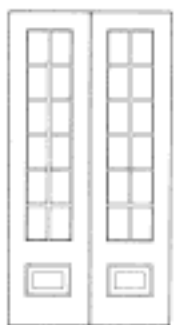

D-25



D-26



D-27

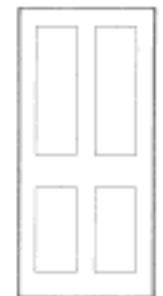

D-28

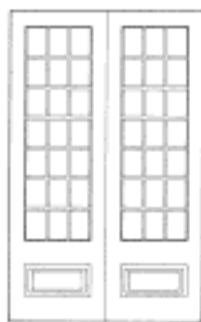

D-29



D-30

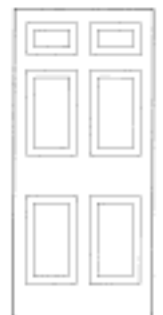
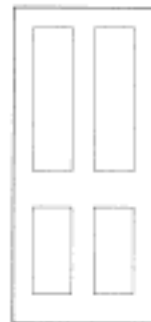

D-31



Elevation and profiles of door types

## RECOMMENDATIONS

Accurate restoration work is not easy and often requires extraordinary dedication to excellence. Trained architects and craftsmen develop a sensitivity to historic materials and the way they were utilized. Restoration specialists understand that inappropriate, expedient solutions often cause irreparable damage.

The renovation and installation of building systems often causes substantial damage to historic buildings. New electrical, plumbing and mechanical systems often require large amounts of space and destruction of original building fabric. Building systems can be camouflaged once they have been installed; however, it is the underlying damage inflicted by their installation that threatens the building's integrity. To minimize the physical and aesthetic effect on the building, limitations should be placed on modern amenities. Occupants of such significant historic buildings should not expect the same levels of comfort and convenience found in new structures.

Utility systems for significant historic buildings should be designed only by engineers who specialize in the integration of building systems in historic structures, and the work should be coordinated with restoration architects to insure that the least intrusive methods of installation are pursued. Building systems must be skillfully designed to provide adequate levels of comfort while conforming to strict building conservation requirements.

Concern for preservation should be extended to all original building fabric and to the cumulative history of the structure. Windows, doors, hardware, floorboards, traditional plaster construction, and decorative finishes should be conserved and maintained. Where elements are missing they should be replaced with exact, dated replicas. Original material, including that which is considered seemingly insignificant, should never be replaced for cosmetic reasons, nor for the convenience of construction. Period nails and screws are as invaluable to Jefferson's buildings as are the architectural moldings.

*In situ* repair and stabilization is the preferred method of conservation for original wood and plaster elements. These materials should never be replaced *in toto*, and care must be taken to preserve such historic building material throughout the restoration process.

## PAVILION V

### EXTERIOR

#### ROOF

The original ridge-and-furrow roof now in the attic is of major historic significance. It is the best preserved of Jefferson's ridge-and-furrow roofs, which were unique to Monticello, Poplar Forest, and the University of Virginia. It is especially significant because not only have the rooflets survived intact, but the roof hatch and flashings remain unaltered. The proposed renovation work, particularly the installation of new mechanical systems, should be done in a manner that does not damage or compromise the significant features of the original Jefferson-designed roof.

Although the slate roof on the original building was replaced in the 1980s, it appears that no effort was made to restore the built-in rainwater diverters of the 1837 hipped roof. The existing downspout locations may or may not correspond with those for the mid-nineteenth century roof. When future roof work is undertaken, the roof on the original building should be investigated to determine if the downspouts can be relocated, in accordance with the remaining physical evidence, to provide more positive drainage.

Additional work on the roofs of the original pavilion, the connecting hyphen, the rear addition and the west porch includes the following:

1. Remove leaves and debris from the roofs and gutters.
2. Re-design sheet metal flashing at the juncture of the original building and the roof of the connecting hyphen.
3. Paint sheet metal roofing, downspouts and hung gutters.
4. Replace galvanized ogee gutter at perimeter of west porch with a historically appropriate hung gutter.
5. Restore balustrades on roof terraces of connecting hyphen, eliminating expedient repairs that utilized elastomeric roofing membrane.

#### MASONRY WALLS

The exterior brick walls should be carefully cleaned and repaired. Existing portland cement mortar repairs and improperly matched white and colored mortars should be removed and new lime-rich mortar installed. The masonry work should include the following:

## RECOMMENDATIONS

1. Clean exterior brick walls using a mildly acidic masonry cleaner.
2. Remove all deteriorated mortar and replace with lime-rich mortar matching the original in color, texture, density and tooling. If possible, all portland cement mortar should be removed as well; however, further investigation should be undertaken to determine if the cement mortar can be removed without causing significant damage to the adjacent brick. After pointing, settlement cracks should be monitored to determine whether movement has been arrested.
3. Dry brush efflorescence from brickwork and use mild chemical cleaning agents to remove biological growth and other types of staining. No chemicals should be used that will damage the masonry.
4. Replace broken and badly spalled bricks.
5. Correct exterior drainage to help prevent rising damp.
6. Remove surface-mounted electrical conduit, coaxial television cable and telephone wiring from exterior wall surfaces.
7. Remove the Canadian hemlock tree located three feet from the northwest corner of the rear addition.

### AREAWAYS

1. Correct drainage problems in the areaways to the north, west and south of the original building. Replace broken brick pavers.

### WINDOWS

1. Remove all loose, crazed and peeling paint using hand-scraping techniques.
2. Remove wire mesh and plastic sheeting from basement window wells on east elevation. Replace broken wood bar in reveal of basement window.
3. Remove mildew growth on windows and blinds with a diluted bleach solution.
4. Repair deteriorated wood using epoxy consolidants and fillers.
5. Where compound cracks occur within a window pane, and excess air penetration has developed, replace glass with compatible restoration glass. The restoration glass should have the year of replacement etched in a corner.
6. Replace deteriorated glazing putty and repaint sash.
7. Rehang all sash to ensure proper operation and to reduce excessive air penetration.



## PAVILION V

### INTERIOR

The interior spaces, especially those in the original building (1819-1823), should be preserved in their historic forms and restored where necessary. Original paint colors and interior finishes should be replicated; wallpaper should be installed where there is sufficient evidence to confirm its initial use.

Pavilion V should continue to be used as a residence; however, modifications should be made to convert the two existing residences to a single residence. With the establishment of a single residence, service facilities can be located in the connecting hyphen and rear addition. This will allow a more conservative preservation approach to be taken in the original Jeffersonian spaces. The large size of the building may also facilitate its use for informal teaching space. Within the original building, residential functions should be accommodated much as they have been, with the more formal spaces on the first floor, family bedrooms and sitting rooms on the second floor, and informal living and storage spaces in the basement.

All spaces that require plumbing — bathrooms and kitchens — should be located in the hyphen or rear addition. In this way the original building can be spared the mutilation caused by the installation of piping and the damage resulting from plumbing leaks.

#### *Basement*

1. Install brick flooring to match original flooring.
2. Restore fireplaces to original form.
3. Remove existing heating pipes and exposed plumbing.
4. Remove surface-mounted electrical conduit.
5. Replace deteriorated and moisture-damaged wall and ceiling plaster.
6. Remove inappropriate modern casework and finishes.
7. Repair deteriorated and modified woodwork.
8. Renovate bathroom and laundry facilities.
9. Repair all period hardware and replace modern hardware with appropriate reproductions.

#### *First Floor*

1. Remove modern partitions constructed at the east and west ends of the central hall in the original building and restore the original west entry door.
2. Re-design the closures for the original window openings in the west wall of the

## RECOMMENDATIONS

dining room (Room 103).

3. Replace deteriorated and moisture-damaged plaster.
4. Rake out settlement cracks and replaster.
5. Repair deteriorated and modified woodwork, including cornices.
6. Repair damaged floorboards.
7. Restore fireplaces to original form.
8. Renovate kitchen and bathroom facilities.
9. Remove unused electrical junction boxes and repair plaster ceiling and wall surfaces.
10. Repair all period hardware and replace modern hardware with appropriate reproductions.

### *Second Floor*

1. Replace deteriorated and moisture-damaged plaster.
2. Rake out settlement cracks and replaster.
3. Repair deteriorated and modified woodwork, including cornices.
4. Repair damaged floorboards.
5. Chemically remove heavy paint build-up from elaborate plaster frieze in master bedroom (Room 205).
6. Remove unused electrical junction boxes and repair plaster ceiling and wall surfaces.
7. Remove inappropriate modern casework.
8. Renovate bathroom facilities.
9. Repair all period hardware and replace modern hardware with appropriate reproductions.

### *Attic*

1. Clean and vacuum Jefferson's ridge-and-furrow roof, encapsulated beneath the existing hipped roof.
2. Catalog artifacts found within attic space above the original building.
3. Verify that existing knob-and-tube wiring is inactive. This wiring should be maintained *in situ* as an artifact of the building's electrification.
4. Prepare large format photographic negatives of ridge-and-furrow roof.
5. If the fireplaces within the original building are to remain in use, selective pointing repairs are required at the chimney.
6. As a safety precaution, the holes in the ridge-and-furrow roofing should be bridged or closed in a reversible manner.

## PAVILION V

### UTILITY SYSTEMS

#### *Electrical System*

1. Replace entire electrical system.
2. Remove existing light fixtures and install fixtures appropriate to the historical quality of the building.

#### *HVAC System*

1. Remove existing heating system, including pipes and radiators.
2. Investigate installation of a new forced-air HVAC system to provide heating and air conditioning. Equipment for the new system should be located in mechanical spaces beneath the student dormitory rooms and within the connecting hyphen and rear addition of the pavilion.
3. The new heating and cooling system should utilize the university's central hot and chilled water plants.

#### *Plumbing System*

1. Replace entire plumbing system as part of the renovations for bathroom and kitchen facilities.

#### *Fire Detection and Suppression Systems*

1. Install a fire detection system throughout the building that utilizes heat and ionization detectors and communicates with a central reporting facility.
2. Investigate the installation of a limited fire suppression system utilizing sprinklers. Such a system should be considered for attic and mechanical spaces. It is not recommended that the first and second floors of the original building be sprinklered because of the damage that would be caused by the installation of such a system.
3. Fire extinguishers should be discreetly located throughout the building. The installation of these appliances should not cause damage to building materials.

#### ILLUSTRATION ACKNOWLEDGMENTS

Illustration on page 12 taken from *The Lawn: A Guide to Jefferson's University* by Pendleton Hogan, University Press of Virginia, Charlottesville. Illustrations on page 70-71, 74-75, 79, 99, and 121, courtesy of Ashley Robbins, University of Virginia Department of Facilities Management. Illustrations on cover, title page, and pages 44-53, 72, 76-78, 80, 96-97, 119-120, 130, 140-144, 146-147, 160, and 180 by Mesick • Cohen • Waite Architects.

Photographs on pages 10 and 14, courtesy of Manuscripts Department, University of Virginia Library. Photographs on pages 20, 24, and 30 (Thomas Jefferson Papers) and on page 18, courtesy of Special Collections Department, Manuscripts Division, University of Virginia Library. Photographs on pages 148 (Prints Collection), 32 (Proctors Papers), 22, and 39, courtesy of Special Collections Department, University Archives, University of Virginia Library. Photographs on pages 54, 58, 62, 64, 66, 67, 81, 85, 86, 90, 92, 94, 100, 103, 104, 105, 106, 108, 111, 114, 116, 122, 124, 125, 126, 127, 128, 129, 137, and 138 supplied by James Murray Howard, Curator and Architect for the Academical Village. Other photographs by Mesick • Cohen • Waite Architects.

